

SAUDI
MADE



صناعة
سعودية

رؤية
VISION
2030
المملكة العربية السعودية
KINGDOM OF SAUDI ARABIA



شركة مصنع جاما للصناعات المعدنية GAMMA FACTORY FOR METAL INDS.

MORE THAN **15** YEARS IN MANUFACTURING OF :

- 19" Network, Telecom, Cabinets & Accessories
- IP/NEMA Outdoor Enclosures
- NEMA x Stainless Steel Enclosures
- Power Distribution Unit (PDU)



GAMMA PER QUALIFICATIONS - 2025

1. COMPANY PROFILE :

- ABOUT US
- VISION AND MISSION
- OUR VALUES
- QUALITY CONTROL
- PRODUCTION FACILITY
- OUR PRODUCTS
- CERTIFICATES
- EXPORT
- END USERS
- PROJECTS
- REFERENCE LIST
- GAMMA PRODUCT GALLERY
- CONSULTANT APPROVALES
- CONTACT US

2. PRODUCT TECHNICAL DATA SHEET :

- WALL MOUNT CABINETS (6U to 21U)
- FREE STAND CABINETS (18U to 47U)
- DATA CENTER CABINETS (42U to 47U)
- OPEN RACK FOR TELECOME (22U to 47U)
- COMPARTMENT FREE STAND CABINET (21U to 47U)
- IP54 TELECOME CABINETS (all sizes available on request)
- SOUND PROOF TELECOME CABINETS (all sizes available on request)
- IP 66 OUTDOOR 19" CABINETS AND ENCLOSURES WALL/POLE MOUNT
- IP 66 OUTDOOR FREE STAND 19" CABINETS WITH COOLING FAN
- IP 66 OUTDOOR ENCLOSURES WITH COOLING FAN
- IP 66 FEC CABINETS WITH AIR CONDITIONING & MONITORING INTERFACE
- BATTERY CLOSE RACK CABINETS



ABOUT US

With more than 15 years experience **GAMMA FACTORY FOR METAL INDS.** is a major player in Saudi Arabia Market with more than 100,000 cabinets installed all over the kingdom. **GAMMA** specializes in Manufacturing of 19" Cabinets and IP rated enclosures for data communication equipment, utilizing 19" racks, cabinets and accessories, to provide solutions for networking, servers, data centers, outdoor applications, industrial usage and telecommunication.

In 2025, **GAMMA** opened its new Plant in Kharj Industrial Area – Modon – with 7000 sqm area having state-of-the art Robotic equipment and flexible Sheet Metal Machines.

Owns and operates state-of-the art computer-assisted Robotics machinery and equipment and flexible machinery to ensure a high manufacturing capacity and the highest standards of technology is incorporated at every stage of production from raw materials to assembly line and quality control to delivery.

Uses high technological CNC machines (laser cutting, Punching, laser welding, Robotics bending center, & bending etc.), automated robotics electrostatic powder coating line with surface treatment process technological.





OUR VISSION

To lead the market with high-performance, 19 " cabinets and Data Center solutions , customized cabinets that support the backbone of modern telecommunications and data storage systems."



OUR MISSION

Our mission is to design and manufacture cutting-edge telecom cabinets and data center solutions that ensure seamless connectivity and durability, meeting the highest industry standards.



OUR VALUES



**INNOVATIVE
& COLLABORATIVE**



**ETHICAL
& RESPONSIBLE**



SAFETY FIRST



**BEST-IN-CLASS
QUALITY**



**CUSTOMER
DRIVEN**



**SAUDI
MADE**



QUALITY CONTROL



STATE OF THE ART PRODUCTION TECHNOLOGY



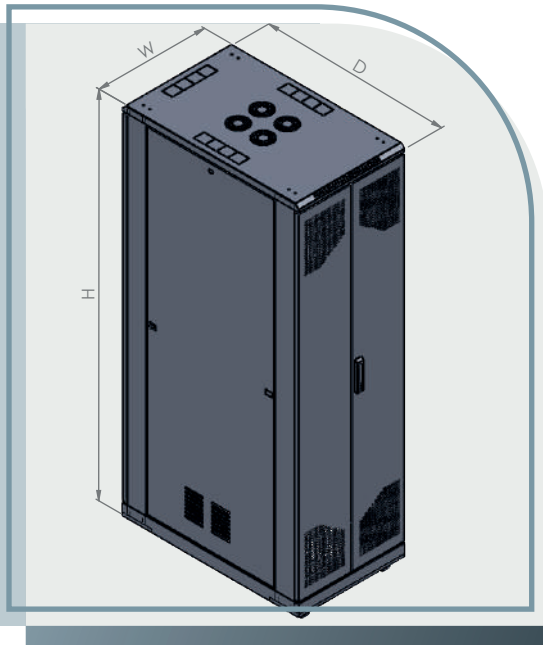

3 D ENGINEERING
SOFTWARE



CNC FIBER LASER
CUTTING MACHINES



ROBOTIC BENDING
CENTER WITH 2 ROBOTS



FIBER LASER ROBOTIC
WELDING MACHINES



AUTOMATIC POWDER
COATING LINE WITH
NANO TECHNOLOGY



ASSEMBLY AREA

OUR PRODUCT LINE

*FULL PRODUCT AND DATA SHEET
CATALOGUE AVAILABLE ON REQUEST*

GAMMA CABINETS COMPLYING WITH INTERNATIONAL STANDARD:

- ISO 2015: 9001 QUALITY MANAGEMENT SYSTEMS
- ISO 14001:2015 ENVIRONMENTAL MANAGEMENT SYSTEM
- EIA/ECA- 310 E & EIA310- D
- IEC 297-1 91" MOUNTING
- IEC 297-2 OVERALL CABINET DIMENSIONS
- IP20 PROTECTED FOR INDOOR CABINET
- IP65/IP66 PROTECTED FOR OUTDOOR CABINETS
- LOCAL CONTENT CERTIFICATE
- MADE IN SAUDI ARABIA CERTIFICATE
- MONSHAAT CERTIFICATE

Specifications and datasheets are subject to change without prior notice.

OUR
PRODUCTS



DATA CENTER



FREE STAND CABINETS



WALL MOUNT CABINETS



**OUTDOOR CABINETS
IP66 POLE/WALL TYPE**



**OUTDOOR FEC CABINETS
IP66 FREE STAND**



**OUTDOOR FEC CABINETS IP66
WITH AC**



FLUSH MOUNT CABINET



ONU CABINET

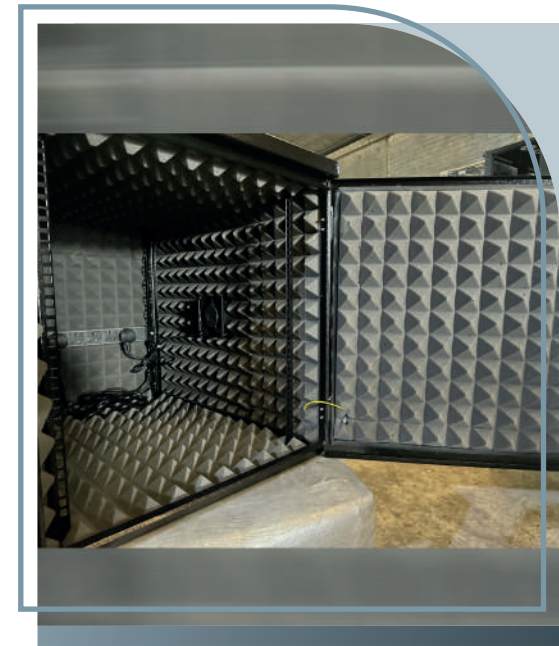

SOUND PROOF CABINETS

OUR PRODUCTS



BATTERY RACK CABINETS



OPEN RACK



POWER DISTRIBUTION UNIT
PDU

CERTIFICATES & APPROVALS





منشآت
monsha'at



اسم المنشأة: شركة مصنع جاما للصناعات المعدنية شركة شخص واحد	تاريخ الإصدار: 29-03-2024	رقم الشهادة: 24176134446
السجل التجاري: 1010278376	الرقم الوطني: 7003104309	صاحبة الشهادة: سنة من تاريخ الإصدار *

تشهد الهيئة العامة للمنشآت الصغيرة والمتوسطة "منشآت" بأن المنشأة المذكورة أعلاه تدرج من ضمن المنشآت الصغيرة والمتوسطة وفقاً للتعريف المعتمد لدى "منشآت"

يتم التحقق من الشهادة من خلال موقع منشآت

<https://profile.monshaat.gov.sa/validate>

تعد هذه الشهادة من الوثائق الحكومية الرسمية، ولا يجوز تداولها أو استعمالها إلا في حدود الأغراض التي أصدرت لأجلها، ويحظر قطعياً تقليدها أو إدخال أي تعديلات عليها سواء بالإضافة أو الحذف أو التغيير في بياناتها أو غير ذلك من أنواع التعديل. وتعد هذه الشهادة كوثيقة إلكترونية لها قيمة قانونية، كما تعرض من ارتكب أي معاقبة إدارية أمام الجهات المختصة دون الإخلال بما نص عليه الأنظمة ذات العلاقة.

* يجب التحقق من خلال رابط موقع منشآت عن صلاحية الشهادة حيث أنه يتم التحديث بشكل دوري

التاريخ: 2024/07/30
رقم الشهادة: M72532



هيئة المحتوى المحلي
والمشتريات الحكومية
Local Content & Government
Procurement Authority



شهادة المحتوى المحلي Local content certification

The Local Content & Government Procurement Authority certifies that the Local Content Score for [Gamma Factory For Metal Industries] Commercial Registration No.(1010278376) for the year ended 31/12/2023, is 19.36%.

This certificate expires on 31/07/2025.

Note:
This certificate was issued according to the procedures followed by the Authority and based on the disclosure submitted by the entity and the report issued by the approved audit firm, without holding LCGPA minimally responsible.
This certificate is sent via electronic mail / automated system and it does not require a signature.

تشهد هيئة المحتوى المحلي والمشتريات الحكومية أن نسبة المحتوى المحلي لـ [شركة مصنع جاما للصناعات المعدنية شركة شخص واحد] سجل تجاري رقم (1010278376)، للسنة المالية المنتهية بتاريخ 31/12/2023م، تبلغ 19.36%.

تنتهي صلاحية هذه الشهادة في 2025/07/31م.

توجه:
تم إصدار هذه الشهادة بحسب الإجراءات المنظمة لدى الهيئة بناء على الإفصاح المقدم من المنشأة و التقرير الصادر من مكتب المراجعة المعتمد، دون أن تكون مسؤولة على الهيئة.
هذه الشهادة مرسلة عبر البريد الإلكتروني، النظام الذي لا يتطلب توقيع.

You can validate the information in this certificate via the following link <https://profile.monshaat.gov.sa/validate>, or by scanning the above QR code

يمكن التحقق من صحة البيانات الواردة في شهادة المحتوى المحلي من خلال الرابط الإلكتروني من خلال مسح الرمز مربعي



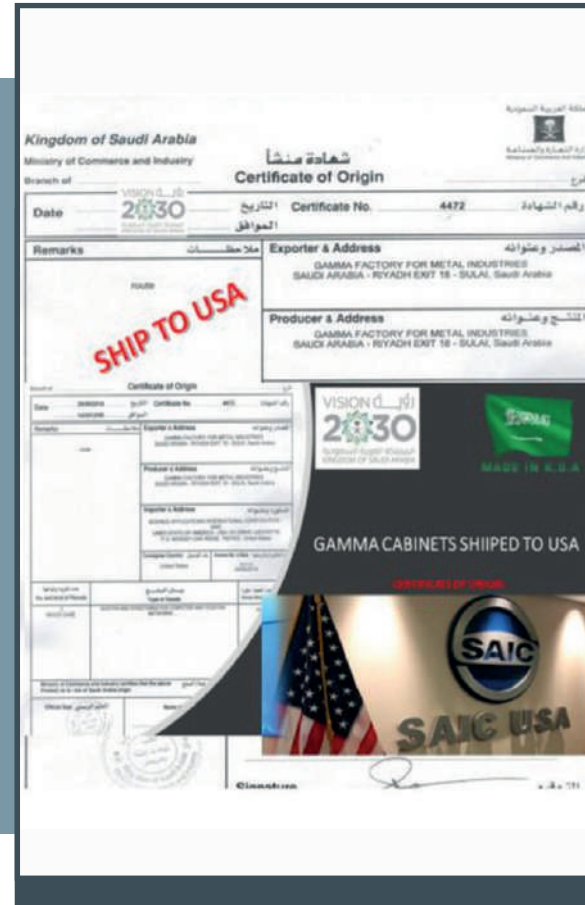

رقم الشهادة: 432222289
 التاريخ: 1446/07/10
 الصافي: 202401120

المملكة العربية السعودية
 وزارة الصناعة
 والتجارة والحرف اليدوية

شهادة منشأ
 للمنتجات الوطنية لكونها منسوبة لكون المنتج العربية

اسم المنتج وطرقه:
 منتج مواد البناء الحديدية - المنطقة الحرة السعودية - الرياض
رقم المنتج وطرقه:
 30 41 03 14006

ملاحظات:
 اسم المستورد والمصدر وطرقه:
 شركة الغزالي للتجارة - الشركات العامة - الرياض
 الرقم: 11 141 888 حتى 1315 على 013 هاتفه

رقم تاريخ التصدير:
 (074-768 - 85810128)

الرقم (الرقم)	الرقم	عدد الطرود وتوجيهها	وصف المنتج	رقم المنتج وطرقه (EIN Code)
4000	4330	100 - كرتون	مادة بناء حديدية	80170280
300	372	10 - كرتون	مادة بناء حديدية	80170280

تصديق وزارة الصناعة والتجارة والحرف اليدوية السعودية بين المصنع والمصدر أو المصدر المصنوع (إلا في حالات استثنائية)
 رقم التصدير: 12345
 التاريخ: 1446/07/10

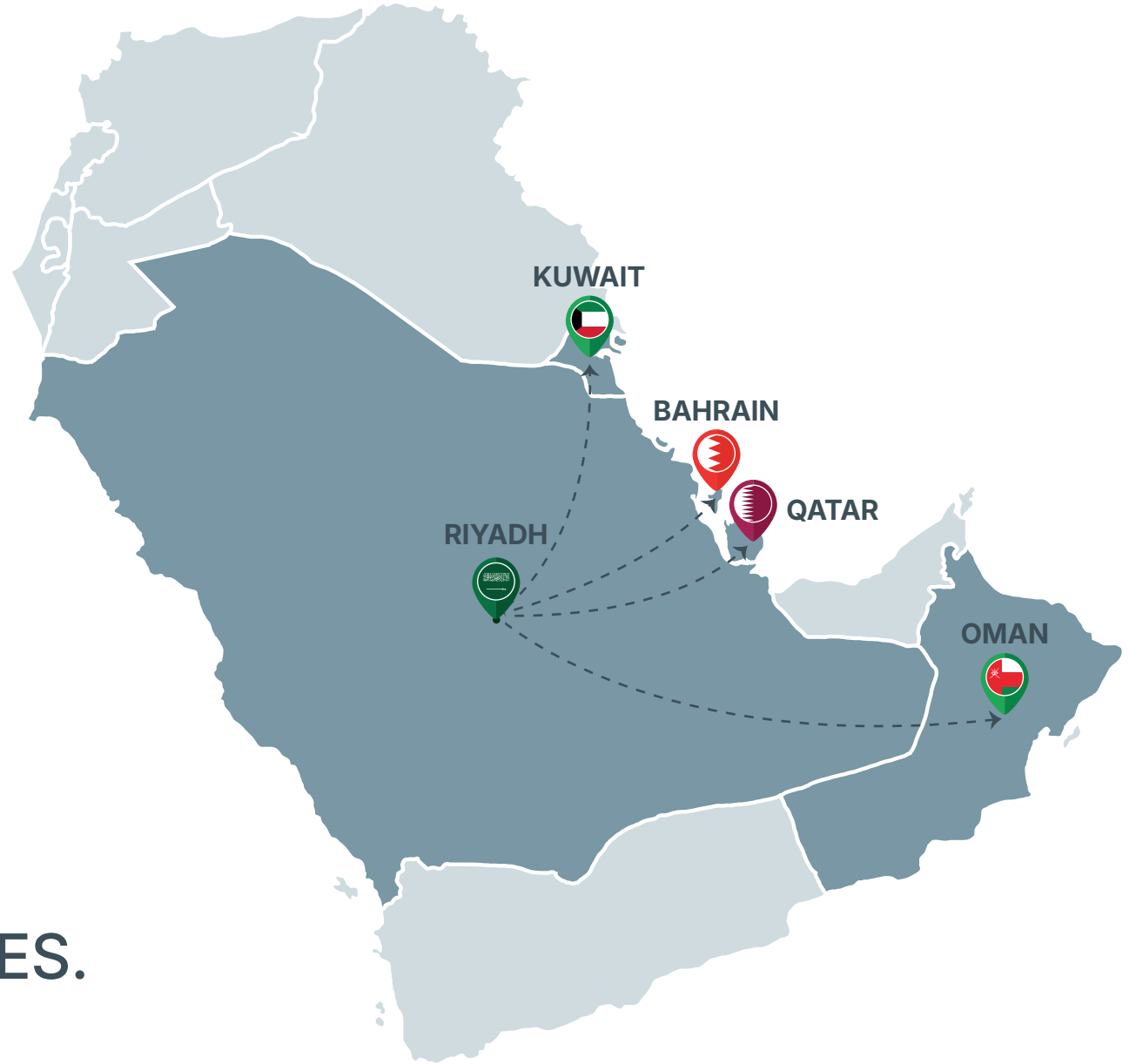

WE **EXPORT** TO
THE GULF COUNTRIES.

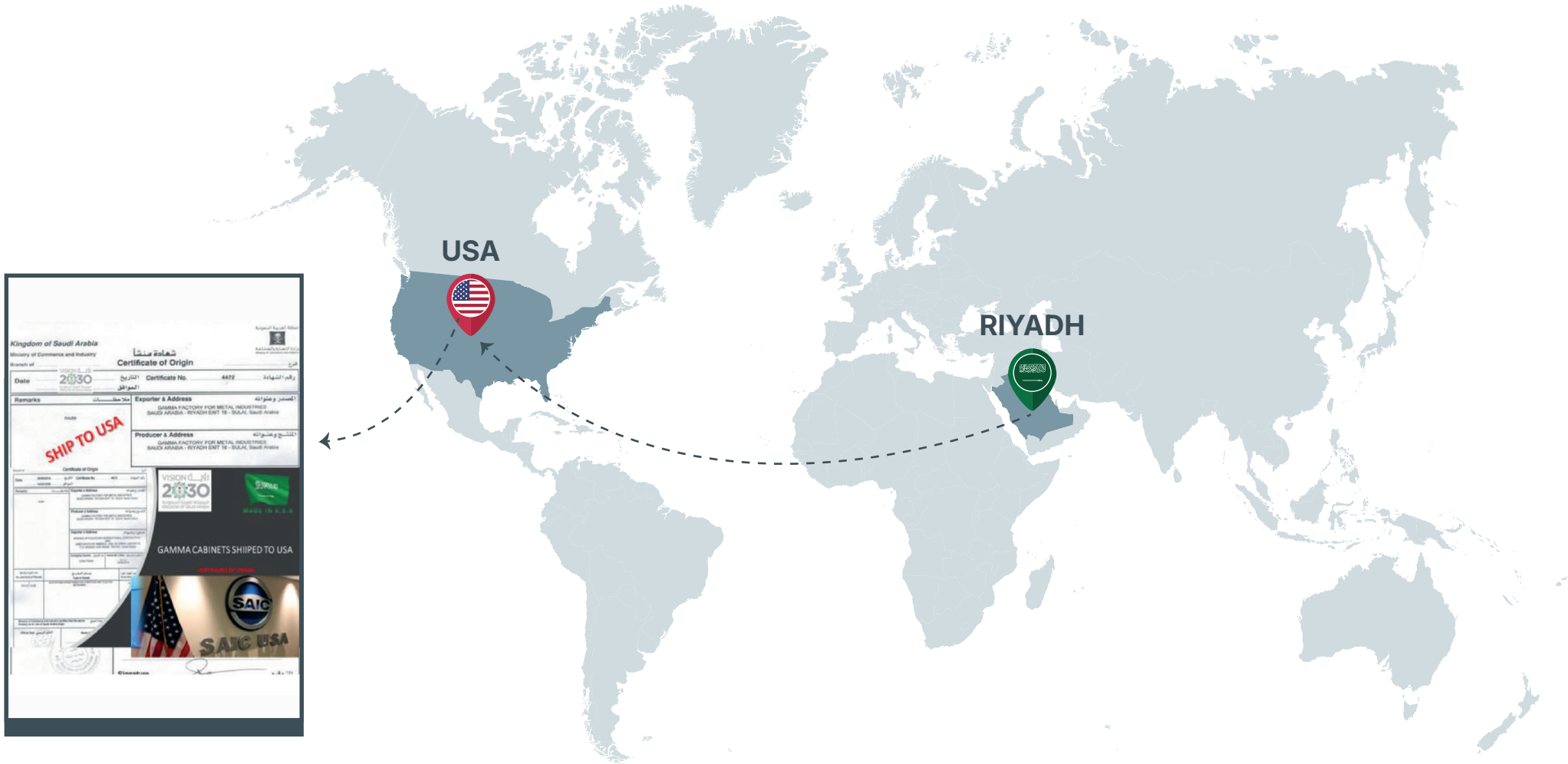

WE ALSO **EXPORT**
WORLDWIDE.



END USERS & PROJECTS

END USERS



END USERS



END USERS



المملكة العربية السعودية
هيئة التحقيق
والادعاء العام
THE BUREAU OF INVESTIGATION
AND PUBLIC PROSECUTION



GAMMA CABINETS INSTALLED
IN BELOW PROJECTS



RED SEA INT'L AIRPORT



KING KHALID INT'L AIRPORT



ALAHSA INTERNATIONAL AIRPORT



JEDDAH ISLAMIC PORT



KING ABDULLAH FINANCE
DISTRICT- KAFD



RED SEA PROJECTS



AMMALA PROJECTS



KING ABDUALAH SECURITY DISTRICT

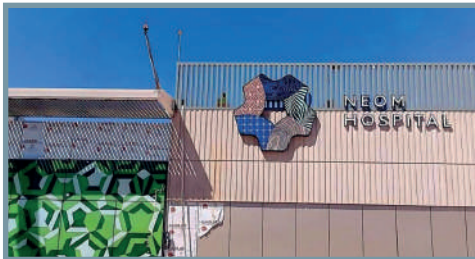

NEOM HOSPITAL



MOWASAT HOSPITAL - JEDDAH



KING ABDULA MEDICAL CITY - BAHRAIN



QASEEM HOSPITAL

GAMMA CABINETS INSTALLED IN BELOW PROJECTS



MARRIOT DIPLOMATIC QUARTER



BOULEVARD CITY



CITY WALK - JEDDAH



TWIN TOWER - SUMO - JEDDAH



RAMMLAH TOWER



ALSHABAB STADIUM



KING ABDULAH SPORT CITY
JAWHRA STADIUM



KING FAHAD STADIUM

REFERENCE LIST

PROJECT	END USER	CONSULTANT	المشروع
The red sea development company	The red sea development company	Al kifah Contracting Company	تطوير البحر الأحمر
King Abdullah security project KAP1	Ministry of Interior -MOI	KHATEEB & ALAMI Consultant	مركز الملك عبدالله للمقرات الأمنية
King Abdullah security project KAP2	Ministry of Interior -MOI	PROGER Consultant	مركز الملك عبدالله للمقرات الأمنية
King Abdullah security project KAP-2B	Ministry of Interior -MOI	NKY	مركز الملك عبدالله للمقرات الأمنية
King Abdullah security project KAP-2C	Ministry of Interior -MOI	NKY	مركز الملك عبدالله للمقرات الأمنية
King Abdullah security project KAP4	Ministry of Interior -MOI	PROGER Consultant	مركز الملك عبدالله للمقرات الأمنية
Royal Commission for Riyadh City (RCRC)	Royal Commission for Riyadh City	DAR AL OMRAN	الهيئة الملكية لمدينة الرياض
Security Force Medical Center (SFMC)	MOI	Manens-Tifs SA	المركز الطبي لقوات الأمن
200 BED HOSPITAL - TABUK	Ministry of Health MOH	KHATEEB & ALAMI Consultant	مستشفى 200 سرير - تبوك
HAJ COMMAND AND HOLLY CAPITAL PROJECT	MOI	PROGER Consultant	مشروع قيادة الحج
King Salman Hospital	MOH	ALFOUZAN	مستشفى الملك سلمان
Marriott Executive Apartment	Riyadh	KHATEEB & ALAMI Consultant	فندق شقق الماريوت التنفيذية
South Border Guards Housing	Ministry of Interior -MOI	ARCHEN	إسكان الحدود الجنوبية
AL SALAM PALACE	JEDDAH	Saudi Diyar Consultant	قصر السلام
King Abdulla Finance District - KAFD	Ministry of Finance -MOF	DAR ALRIYADH Consultant	مركز الملك عبدالله المالي
Jeddah Islamic Port	Saudi Ports Authority	Marwan Ashour Consultant	ميناء جدة الإسلامي
Ministry of Municipal and Rural Affairs	MOMRA	ADD Engineering Consultant	وزارة الشؤون البلدية والقروية
Building of Secretary of the GCC	Gulf Cooperation Council - GCC	Specialist for Geometric	مبنى الأمين العام لمجلس التعاون
Radusson Blue Hotel	Al Khobar	EHAFF Consultant	فندق راديسون بلو
National Water Commission (NWC)	NWC	AL ROKEN CONSULTANT	الهيئة الوطنية للمياه (NWC)

PROJECT	END USER	المشروع
General Directorate of investigation	GID DATA CENTER - JEDDAH	المديرية العامة للمباحث
The Saudi Central Bank (SAMA)	SAMA	البنك المركزي السعودي
NEOM Hospital	NEOM	مستشفى نيوم
New Boulevards	General Entertainment Authority	البوليفرد - الهيئة العامة للترفيه
Winter Land	General Entertainment Authority	ونتر لاند - الهيئة العامة للترفيه
City Walk Jeddah	General Entertainment Authority	سيتي ووك جدة - الهيئة العامة للترفيه
Nuclear and Radiological Regulatory	NRRC	هيئة الوقاية النووية والإشعاعية
ARAR AIRPORT	General Authority of civil Aviation	مطار عرعر
VSAT BACKUP HUB FOR SCECO	SCECO	الهيئة السعودية للكهرباء
National Water Commission (NWC)	NWC	الهيئة الوطنية للمياه (NWC)
World Trade Center - WTC	King Abdulla Finance District - MOF	مركز الملك عبدالله المالي
ISLAMIC University	Madinah University - MOE	الجامعة الإسلامية
Samsung C&T	Rabigh2- Project	سامسونج - رابغ
AL ULA University	Taiba University _ MOE	جامعة العلا - جامعة طبية
Imam Moh'd University	Imam Moh'd University - MOE	جامعة الإمام محمد
Prince Satam University	Prince Satam University - MOE	جامعة الأمير سطام
AI - Jouf University	AI - Jouf University - MOE	جامعة الجوف
Hafar Al-Batin University	Hafar Al-Batin University - MOE	جامعة حفر الباطن
Taima & Hakel University	Tabuk University - MOE	جامعة تيماء وحقل
Hakel University	Tabuk University - MOE	جامعة حائل

REFRENCE LIST

PROJECT	END USER	المشروع	PROJECT	END USER	المشروع
STC WI FI 3G Offloading Project - KASC Jeddah	STC	مدينة الملك عبدالله الرياضية	Schools Infrastructure Development - wave 2	MOE	شركة تطوير للمباني TBC
Ministry of Health - MOH West - MOH ESTERN	Ministry of Health - MOH	وزارة الصحة - المراكز الطبية	Rotana Hotel	Riyadh	فندق روتانا
DIGITAL TRUNKED RADIO SYSTEM WOA	SCECO	الهيئة السعودية للكهرباء	Plazza in Hotel	Riyadh	فندق بلازا ان
Qasem Hospital	Ministry of Health -MOH	مستشفى القصيم	Half Moon Beach Hotel	Al-Khobar	فندق هاف مون بيتش
MOH - PHC	Ministry of Health -MOH	وزارة الصحة - الرعاية الصحية الأولى	Hyat Regency Hotel	Riyadh	فندق حياة ريجنسي
Qasem University Hospital	Qasim University	مستشفى جامعة القصيم	Hilton Garden in Hotel	Tabuk	هيلتون جاردن
Riyadh Metro	RMTC	مترو الرياض	Park Inn - Jeddah	Jeddah	فندق بارك ان - جدة
General Commission for Survey - Phase 3 & 2	GCS	الهيئة العامة للمساحة	Park Inn hotel - JRIYADH	RIYADH	فندق بارك ان - الرياض
General Directorate for Health Affairs	Ministry of Health -MOH	المديرية العامة للشؤون الصحية	Narsis Buder Hotel	Riyadh	فندق نارسيس بوديل
MOI CCTV Project	Qassim Emirates	مشروع كاميرات المراقبة لوزارة الداخلية	Makan Hotel	Al Ahsa	فندق مكان
E - learning Project - Tatweer -School Project	Ministry of Education - MOE	مشروع التعليم الإلكتروني	MUNICIPALITY OF MEDINA	MUNICIPALITY OF MEDINA	بلدية المدينة المنورة
Royal Saudi Navy Force - RSNF	Ministry of Defense - MOD	القوة البحرية الملكية السعودية	Tabuk Emirate	Tabuk Emirate	إمارة تبوك
Saudi Electronic University	Ministry of Education - MOE	الجامعة السعودية الإلكترونية	MUNICIPALITY OF TAIF	MUNICIPALITY OF TAIF	بلدية الطائف
Royal Saudi Air Force - RSAF	Ministry of Defense - MOD	القوات الجوية الملكية السعودية	Eastern Province Emirate	Eastern Province Emirate	إمارة المنطقة الشرقية
Strategic Missile Force -SMF	Ministry of Defense - MOD	قوة الصواريخ الاستراتيجية	Security Development and Planning Agency	MOI	وكالة التطوير والتخطيط الأمني
SAIC - RSAF PROJECT - USA	SAIC - USA	مشروع القوات الجوية الملكية - الولايات المتحدة الأمريكية	Royal Private Affairs	Palace	قصور ملكية
King Abdul Aziz Center National Dialogue	General Authority of Civil Aviation	مركز الملك عبد العزيز للحوار الوطني	VSAT -COGS	SCECO	في سات
National Center for Technology Electrical Energy Systems	King Abdulaziz city for Science and Technology - KASCT	المركز الوطني لتكنولوجيا أنظمة الطاقة الكهربائية	Technical and Vocational Training Corporation	TVTC	المؤسسة العامة للتدريب التقني والمهني
Qassim Emirates	Qassim Emirates	امارة القصيم	MIFON Project Phase 3	Ministry of Interior - MOI	المرحلة 3 MIFON مشروع
SOIETZ Saudi Organization for Industry	MODON	الهيئة السعودية للمدن الصناعية	King Abdullah University Hospital	KAAUH	مستشفى جامعة الملك عبد الله بن عبد العزيز



GAMMA PRODUCT GALLERY

GAMMA PRODUCT GALLERY



GAMMA PRODUCT GALLERY



CONSULTANT APPROVALS

KING ABULLAH FINANCIAL DISTRICT

MATERIAL INSPECTION REQUEST (MIR)

Contract No: KAFO-30 Parcel - Zone 04 Work Package No: [] MIR No: 2016-MIR-EL-1360 REV.0 Date: 10-09-2015

DESCRIPTION OF MATERIAL: GAMMA SINGLE SECTION WALL MOUNT CABINET, MODEL GMM30-VMS-2148 FOR VOICE AND DATA CABLING SYSTEM

MATERIAL QUANTITY: AS PER ATTACHED BTC delivery note (only SR 1) dated 03 September 2015

MATERIAL SUBMITTAL REF No.: DR16P-006-M1.6-0025-REV.0, COOC-0

INSQ REF No.: 10715

MANUFACTURER (Name & Address): M/S. EYSTRAX, M/S. GAMMA FACTORY FOR METAL IND. BTC

SUPPLIER (Name & Address): BTC

LOCATION OF USE: KAFO 30 Parcel Zone 4

PARCEL: Parcel 4

Inspection By: Contractor's QA/QC Date: 06 SEP 15
 Name: SAIED BASH UL-HUSSAIN Sign: [Signature] Title: 9188 JAW
 Remarks: MATERIALS WERE INSPECTED IN SITE STORE AND FOUND OK FOR PER SUBMITTAL AND BTC delivery note (only SR 1) dated 03 September 2015

Approved by Contractor: [Signature] Date: 09-09-15

Supervision Consultant's Inspection Comments: [Signature] Date: 09-09-15 Time: 9:18 AM
 Name: [Signature] Sign: [Signature] Title: [Signature]
 Remarks: Refer comments on the attached sheet

Resident Engineer Signature: [Signature] Date: 16 Sept 2015

Approved by the Contractor: [Signature] Date: [Signature] Title: [Signature]

Station: [] Owner: [] Supervision Consultant: [] Contractor: [] GAMCO Rep: []

Kingdom of Saudi Arabia
 Security Planning and Development Agency - KAP4 Project

PROGER **RTCC**

Ministry of Interior
 Project Name: Sports Training Center (Project) Submittal No: [] Rev: []
 Project No: 108 SAPH 047 108 - 0028 - T2 - 0013 8
 To: Project Manager - Project Head Office Date: 26-Oct-17

Document / Material Submittal

Description: [] Code [] Book [] Sheet [] Section []
 Submittal For: [] Approval [] Information [] Review [] Site Use []

Attachments: [] Sample [] Catalogue / Manuals [] Compliance Cert. [] Manufacturer Data & Specification [] Drawings [] Photos [] Span Parts List [] Calculation Sheet [] General/Particulars [] Other Documents []

Item Description: IP TELEPHONE AND DATA SYSTEM - CABINET RACKS (Alternative Supplier)

Document, Material Description: Reference Spec # []
 IP TELEPHONE AND DATA SYSTEM - CABINET RACKS (Alternative Supplier): 2P 14010

Supplier Data:
 Name: Global Business Solutions
 Address: Office #13, 4th Floor Al Mousa Tower, North Complex, Olaya Street, Riyadh, K.S.A.
 Manufacturer Data:
 Name: GAMMA Factory for Metal Industries
 Address: P.O. Box 280305, Riyadh 11561, Kingdom of Saudi Arabia

Remarks: Reference Approved: 0076 007 100 0028 77 0010

Engineer's Sign: To enter Action Codes, Remarks and return to Contractor

Remarks: ACTION CODE 0
 Central Saudi Factory Cabinet Racks are approved subject to 42 (U 800) W x 1200 D mm perforated double door on front and back for main communication equipment in main communication room.
 Cabinet Rack 42 (U 800)mm, 22U 800x500 mm, 15U 800x400 mm, 6U 800x400 mm, perforated double door on front and perforated single door on back for sub-communication rooms.

Approved as submitted [] Approved as noted [] Revised and resubmit []
 For Engineer's Use: [] Pending Technical Review: []
 Eng. Mujahid Alhamdi 29-Oct-2017 Eng. Afwan Jadaa 29-Oct-2017

RECEIVED
 RTCC-KAP4 PROJECT
 29 OCT 2017

MATERIAL SUBMITTAL FORM

Submittal No: 132-KAP-20
 Project No: 132-KAP-20
 Location: Tabuk
 Submittal No: ALL
 Submittal Description: 132-MSD-ELSDM-20-BE-CABINETS
 Date & Time: 18 May 2017

MATERIALS DETAILS

Item Description: IP Telephone & Data system - Plastic
 Standard / Specification: IEC 60950-1
 Test Parameters: IEC 60950-1
 Control Agency: Saudi Suggest Method (SEM)
 Control System: []
 Address: P.O. Box 317 Riyadh 11421 KSA

Availability: []
 Status: []

Submitted For: []
 Contractor: []
 Submittal For: []
 Contractor: []

Approved by: [Signature] Date: 04 JUN 2017
 Approved by: [Signature] Date: 17 MAY 2017

Engineer Comments: Code B (conditional Approval) - No. 001 enclosed comment sheet.

Professional Engineer: [Signature] Title: Head of Electrical Date: 17/05/2017

Approved [] Approved as noted [] Rejected []
 For Information [] For Action [] For Technical [] For Approval []

Document Title: Material Submittal

Contract No: KXP-HCC-MAR-ELE-0102E

Date: 21-Feb-24

Manufacturer: GAMMA FACTORY FOR METAL IND.

Material: Communications Racks, Cabinet & PDUs

Contractor: Engr. Ahmed Dahnoun

Client: King Salman Park Foundation (KSPF)

PMO: Saudi Arabian Parsons Ltd (SAP)

Discipline: Electrical

Material Name: Switch Cabinets

Specifications Reference: SECTION 27 11 16 COMMUNICATIONS RACKS, FRAMES AND ENCLOSURES

Manufacturer Name: Gamma Factory for Metal Industries

Location: KSA

Contractor PM: Engr. Ahmad Dahnoun

Signature: [Signature]

Date: 28-Nov-2023

PMCM Material Engineer's Comments: Refer comments on page 3 below for compliance in next revision.

PMCM Project Manager's Comments: [Blank]

Submittal Status: A - Approved B - Approved as Noted C - Revise and Resubmit D - Rejected E - No Action Required

Name: Arshid Sunji

Date: 29/11/2023

PMO's Comments (if Required): [Blank]

Validated/Rejected by PMO: Validated Rejected

Name: [Blank]

Signature: [Blank]

Date: [Blank]

Document No: KSP-XXX-XXX-XXX-MAT-0001_00

Material Submittal Form No: KSP-MSP-PMO-CMT-FRM-0011/01 (07-16-22)

CONTRACTOR: GULF PIONEERS CO. Contracting

OWNER: GENERAL DIRECTORATE OF INVESTIGATION

CONSULTANT: AAW & PARTNERS

PROJECT NO: 2156/1443-4

BUILDING NAME: [Blank]

MAN - MATERIAL APPROVAL SUBMITTAL

REQUEST FOR: [Blank]

DATE: 29-Nov-23

DISCIPLINE: ELECTRICAL

MANUFACTURER: GAMMA FACTORY FOR METAL IND.

LOCAL MANUFACTURER: [Blank]

PRODUCTION FROM: [Blank]

WORK DESCRIPTION: DATA RACK MATERIAL SUBMITTAL

Supplier & Brand: GAMMA For Metal Ind. RCA

CONTRACTOR'S REQUEST: WE CERTIFY THAT THE ABOVE SUBMITTALS HAVE BEEN REVIEWED IN DETAIL AND ARE CORRECT AND IN COMPLIANCE WITH THE CONTRACT DRAWINGS AND SPECIFICATIONS.

ENGR. RASHID SUNJI (Contractor's Engineer)

ENGR. ALI KHODIER (Consultant's Engineer)

Client/Consultant Comments: See the attached comments sheet.

APPROVAL CODES: APPROVED AS NOTED

NAME & SIGNATURE: Engr. Issam Ahmed Ibraheem

DATE: 04/10/2023

NO. OF ATTACHMENTS: [Blank]

PARSONS | WSP | RTCC

MATERIAL SUBMITTAL FORM

Submittal Ref: KSP-RTC-LOP-CMT-ELE-MAT-0296

Revision: 00

Date: 28-Nov-2023

Program: King Salman Park

Project/Package: CPS 10 / Landscape Zone 1A (Ph1 Outside the Loop)

Contract No: 20230524015

Client: King Salman Park Foundation (KSPF)

Contractor: Al Rashid Trading & Contracting RTCC

PMO: Saudi Arabian Parsons Ltd (SAP)

PMCM [1]: Faithful+Gould (FOS)

PMCM [3]: WSP Middle East (WSP)

Discipline: Civil Architecture Mechanical Electrical Information Technology Landscape Others

Material Name: Switch Cabinets

Specifications Reference: SECTION 27 11 16 COMMUNICATIONS RACKS, FRAMES AND ENCLOSURES

Manufacturer Name: Gamma Factory for Metal Industries

Location: KSA

Contractor PM: Engr. Ahmad Dahnoun

Signature: [Signature]

Date: 28-Nov-2023

PMCM Material Engineer's Comments: Refer comments on page 3 below for compliance in next revision.

PMCM Project Manager's Comments: [Blank]

Submittal Status: A - Approved B - Approved as Noted C - Revise and Resubmit D - Rejected E - No Action Required

Name: Arshid Sunji

Date: 29/11/2023

PMO's Comments (if Required): [Blank]

Validated/Rejected by PMO: Validated Rejected

Name: [Blank]

Signature: [Blank]

Date: [Blank]

Document No: KSP-XXX-XXX-XXX-MAT-0001_00

Material Submittal Form No: KSP-MSP-PMO-CMT-FRM-0011/01 (07-16-22)

Page 1 of 2

EDGNET **SALFO** **التحويل العائلي للمقاولات** **CONVERSION**

PROJECT NO.: P157.08
PROJECT NAME: EDGNET RYADH DATA CENTER LOCATION: INDUSTRIAL AREA No 2, RYADH

TECHNICAL SUBMITTAL - MATERIAL

SUBMITTAL NO.: P157.08_MAT_ELE_006_Rev_000 REF NO.: NA

DATE: 16-08-2023 New Submittal Re-Submittal

DISCIPLINE:
 CIVIL ARCHITECTURAL STRUCTURAL MECHANICAL PLUMBING ELECTRICAL OTHER

Drawings Plans Catalogs Certificate Calculations
 Specifications Sample Sketch Supplier Others
 Sub-contractor Test data Schedule Report Clarifications

DOC. NO.	REV.	DESCRIPTION	Q. OR COPIES
P157.08_GC_MAT_ELE_006	3	Data System Passive Components (cabinets + PDU) Model as per attached list Brand: GAMMA for cabinets Brand: SARIX for PDU Origin: ISA	0

ITEM NO. BOQ: LOCATION: USE: **SALFO RECEIVED 10/09/2023**

Is schedule implications? Yes No Are cost implications? Yes No Financially Significant? Yes No Months: SAR

CONSTRUCTION DIRECTOR: PROJECT MANAGER:
 NAME: Signature & Date: NAME: Signature & Date: 16-09-2023

SUPERVISION CONSULTANT REVIEW & COMMENTS:

NAME: Ilias Chronopoulos: **SALFO** Signature & Date: 16-09-2023

ACTION CODES:
 (A) Approved (B) Approved as noted (C) Re-Submit (D) Rejected

Document Submittal

Project Name: BANK AL BALAD BRANCH Project Code: 201104
 Project Start Date: 05/11/2024 Project Location: ADHA
 Contractor Name: SULAIMAN SWAYEH GROUP Consultant Name: AHMED AL-MOUSAWI CONSULTANTS
 Submittal No: 08-80-CL-07-43-REV00 Issue Date: 09/02/2023

Submittal Description

Purpose of Submittal: For Approval For Information

Submittal Discipline: Civil HVAC Others Architecture Plumbing Electrical Fire Fighting

Document Type: Tender Drawing Material Drawing Method Statement Others Design Drawing Vendor / Supplier Approval Test Result Shop Drawing Vendor / Supplier Approval Test Result

Description: **LOW CURRENT 45U CABINET - GAMMA FACTORY FOR METAL IND.**

Contractor Engineer: Eng. Ahmed Fayad (Name) [Signature] (Signature) 09/02/2023 (Date)
 Project Manager: Eng. Mostafa El Khawaja (Name) [Signature] (Signature) 09/02/2023 (Date)

Received By Consultant: _____ (Name) _____ (Signature) _____ (Date)

Consultant Approval: A: Approval B: Approved with Comments C: Revises and Resubmit D: Rejected E: For Information

Comments: **45U 800-1000 19" rack to be provided (project specs).
Warranty & test certificates shall be provided.**

Consultant Engineer: All Said (Name) [Signature] (Signature) 12-02-2023 (Date)
 Required Sign off (Contractor): _____ (Name) _____ (Signature) _____ (Date)

Consultant Project Manager: _____ (Name) _____ (Signature) _____ (Date)

Bank Albalad Review: _____ (Name) _____ (Signature) _____ (Date)

Comments:

BAB Project Manager: _____ (Name) _____ (Signature) _____ (Date)

Received By (Contractor): _____ (Name) _____ (Signature) _____ (Date)

Contractor Project Manager: _____ (Name) _____ (Signature) _____ (Date)

This drawing is owned by the Consultant's Engineer and the Project Manager shall not release the Consultant of its obligation to perform the work in accordance with the Contract documents and requirements of law.

Material Submittal Form

Submittal Ref: D0501-ABR-MAT-ELE-000041 Revision: 00 Date: 26 August 2024

Project Title: AL AROUS - SINGLE FAMILY RESIDENTIAL UNITS (ZONE A, B AND C)
 Package: 1544
 Client: BOSHNI
 Engineer/Consultant: Arabtech Jastaneh (AJ SAUDI)
 Contractor: ABR CONTRACTING CO.

Discipline: CIVIL ARCH MECH ELEC Others

Material Details	List of Enclosure
Specs / BOQ / Drawings Reference: SECTION 27 1513	Copy of related specs
Specified Material: Material submittal for ICT Enclosure	Compliance Statement
Proposed Material: ICT Enclosure	Samples
Manufacturer / Local Supplier: Gamma	Others (Specify)
Reason for Alternative (if any):	
Remarks:	

Contractor Signature (s):
 Material Engineer Sr. QA/QC Manager Technical Manager MEP Manager Project Director

Received By Engineer:
 Name: Signature: Date: Time:

Submittal Status:
 A- Approved B- Approved with Comments C- Revises and Resubmit D- Rejected E- Acknowledged

Engineer's Comments:

Name	Signature	Date
Reviewed by (Engineer)		
Approved by (Engineer)		
Received By (Contractor)		

Distribution:
 Engineer Contractor Others (Specify)

SAPL-GEN-FM1007 Rev. 0.

13 Sindalah Island
Riyadh, KSA
Riyadh
Saudi Arabia

AECOM Delivering a better world

MAIL TYPE: Workflow Transmittal
MAIL NUMBER: ACM-WTRAN-278646
REFERENCE NUMBER: ACM-WTRAN-278646

Final (WF-139072) 13-480000849/000-Infra-IN-Construction - IFR-MAT - ELE-ICT

From: Mr Oussama Kewdah - AECOM
To (2): Mr Oussama Kewdah - AECOM (+1 more...)
Cc (8): Mr Peter Habib - AECOM (+7 more...)
Sent: Saturday, 17 August 2024 12:20:38 PM AST (GMT +03:00)
Status: N/A

DOCUMENT ATTACHMENTS (2)

File	Document No	Revision	Revision Date	Title	Status
	13-253002-480000849-ARA-ICT-CRS-071036	01	08/08/2024	480000849/000 - Material Submittal for ICT Rack Cabinet (Gamma)	B - Incorporate Comments - Proceed
	13-253002-480000849-ARA-ICT-MAT-000011	01	08/08/2024	480000849/000 - Material Submittal for ICT Rack Cabinet (Gamma)	B - Incorporate Comments - Proceed

MESSAGE

Workflow Review History

The attached documents have completed the "13-480000849/000-Infra-IN-Construction - IFR-MAT - ELE-ICT" workflow with the following results:

Doc No	Step	Participant	Review Outcome	Comments
13-253002-480000849-ARA-ICT-CRS-071036	AECOM/PMC Review	O Kewdah	B - Incorporate Comments - Proceed	refer to comments in the attached sheet

Red Sea Global

MAIL TYPE: Workflow Transmittal
MAIL NUMBER: TRS03R02-WTRAN-012631
REFERENCE NUMBER: TRS03R02-WTRAN-012631

Final (WF-003532) Warranty Draft - Data Cabinets - Gamma

From: Najwa Dacu - The Red Sea Development Company
To (16): Mr Shayan Khattak - Al lifah contracting company (+14 more...)
Cc (2): Mr Shadi Alotaibi - The Red Sea Development Company (+2 more...)
Sent: Monday, November 14, 2022 11:14:43 PM AST (GMT +03:00)
Status: N/A

DOCUMENT ATTACHMENTS (1)

File	Document No	Revision	Title	Status
	R03-R02B01-KCC-WAR-OM-0080	00	Warranty Draft - Data Cabinets - Gamma	Accepted with Comments

ATTRIBUTES

Attribute 1: Site Wide

MESSAGE

Workflow Review History

The attached documents have completed the "Warranty Draft - Data Cabinets - Gamma" workflow with the following results:

Doc No	Step	Participant	Review Outcome	Comments
R03-R02B01-KCC-WAR-OM-0080	QA/QC Review	W Alhaddad	Accepted	

MATERIAL APPROVAL REQUEST (MAR)

Contract Title: Mobility Hub (D7 D8 D9)

Ref. No.: P-0013-PH01-D07-07A008-UNE-MAT-ELE-000023
Rev. No.: 04
Project No.: P-0013
Date: 20.08.24
Supervision Consultant: Dar Al Riyadh
Contractor: UNEC

Discipline

Civil Structural Architectural Mechanical Electrical
 HVAC Plumbing Lifts Utilities Other:

Material Details

Material Name: Data and telephone system
Specification Ref. No.: 270553-271000
BOQ Ref. No.: -
Drawing Ref. No.: -
Manufacturer / Supplier Name: Data Active Solution (HUAWEI)
Passive Solution (Corning)
UPS Solution (Legrand)
Racks (GAMA)
Supplier: Dosor Najd Est
Prequalification (PQD) Ref. No.: P-0013-PH01-SIW-MH0001-UNE-PQD-ELE-000040

Contractor Check

This section to be completed by the Contractor prior to the Submission

Position	Name	Signature & Stamp	Date
QA/QC Manager	Engr Mohamed Askar		20.08.24
Projects Director	Engr Essam Anwar		20.08.24

Site Supervision Consultant (DMS/SSC) Comment / Review

Comments:
Refer to the comments mentioned in the below page.

Final Comments & Decision:

Approved Approved with Comments Rejected QA Rejected

Is Employer approval required? Yes No ; Is FLS Supervision Consultant approval required? Yes No

Name: Mohammed Abdul Haseeb
Signature:
Date: 22 August 2024

FLS Supervision Consultant review (where required)

نقل الكهرباء National Grid

PROJECT DEPARTMENT-EAST
Projects Division-Hassa
Phone: 69303 Fax: 69372

Submital No. 17-39185-30303401

Date: 13 December 2017

REQUEST FOR REVIEW OF CONTRACTOR'S SUBMITAL

PROJECT TITLE CONSTRUCTION OF ABQAIQ-3 115/13.8 KV SUBSTATION

CONTRACT NO. 440003695 BI NO.: 1-133303 JO NO.: 1-133303.01

Division Manager, ICD/ICSD/EOA	Division Manager, TMS&E/TDMO
Engineering Specialist, EDD/EDD-TLU	Division Manager, AMD/HF/TS&TD
Senior Engineer, EDD/EDD/SEU	Division Manager, AMD/HSD
Division Manager, GM&EOA/SCADA-E	Division Manager, ISD/S&E/EPD
Supervisor, SA&SD/P&S/DSQS	Division Manager, CSD/CSD-E
Division Manager, PE/DP/D&EOA	Division Manager, AMD/DI/DE/GAN
Division Manager, TE&SAD-E/TE&SAD	Division Manager, PRCD/HED
Division Manager, SOCD/COCED	Others (specify):
Division Manager, O&CD/CSD	

Reference: 1. Submittal No. ACC-Abqaiq-3-NG-E-17, Rev.0.

PLEASE REVIEW THE FOLLOWING AND RETURN WITH YOUR COMMENTS/ACCEPTANCE BY: DATE: 20 December 2017

Material (s) Manual (s) Test Report (s)

Drawing (s) Spare Part (s) Others (Specify):

S. No.	Item	Qty	Remarks
1	Please find attached submission of Data Cabinets for TE&SAD of Abqaiq-3 115/13.8KV Substation for your review and approval. For PDS	1 Set + CD	<ul style="list-style-type: none"> Please e-mail an advance copy of your response to 9966607. Your earliest response by the said date will be highly appreciated. Please provide your comments specific to SOW/TS, ITS - 13EN117

Should you have any question, please contact Sami H. Mahasbi/Wateem Khan on Ext. 69806/69889.

Sami H. Mahasbi
Project Engineer
Projects Dept.-E/Project Div. Al-Hassa

Letter File: CN-440003695/01 File

14 DEC 2017 RECEIVED

1212

1298

Eastern Operating Area
مملكة أعدل الشرقية
مراستات والكهرباء

نقل الكهرباء National Grid

TELECOM ENGINEERING & SUBSTATION AUTOMATION DEPARTMENT
TELECOM ENGINEERING & SUBSTATION AUTOMATION DIVISION
ROOM 1-260E, SEC-EOA HEADQUARTERS, DAMMAM
Tel : 868-6861 Email: 54774@ng.sd
21 DECEMBER, 2017

TE&SAD SUBMITTAL REVIEW REPLY

Ref. No. 17-3298-305032

TRANSMIT TO AS INDICATED BELOW: Subject: REVIEW OF CONTRACTOR'S SUBMITAL

Project Title: CONSTRUCTION OF ABQAIQ-3 115KV SUBSTATION CONTRACT NO. 440003695

Supervisor, TMS&E/SD/POA
 EMOA, Sec's Specialist, PD/C&E/EPD
 Group Leader, RSTO-EE&E/ISD-GAS1
 Project Manager, IS/VPD-GOA
 Project Engineer, PD-E/PO-EMSSA
 Project Manager, T&N/SH/VED-EOA
 Senior Expt., O/ED/PO

DOC. REFERENCE : (S-99185-303034) dated 13-12-2017
DOC. DESCRIPTION : Data Cabinet (for Telecom Station)

TE&SAD COMMENTS MAILED BY CHECKING

Acceptable
 Acceptable Except As Noted
 See Attached Comments
 Rectification Required - Resubmit
 Submittal Not Required
 Use Station - Additional Information Required (Specify Item Addressed red/y)
 Not Acceptable / Resubmit
 No Comment

Note:
1. Ethel and GAMMA Flex are acceptable Data Cabinet, however, Contractor shall use minimum of 10 Data Cabinet inside Telecom Shelter.

HUSSAIN A AL-JISHI
Transmission Engineering Expert
TE&SAD/EM

With Attachment(s)

Letterbook

ROUTE: SA/IN/EP-File: 440003695

نقل الكهرباء National Grid

Southern Border Housing Project

Date/Telephone System Equipment Rack (Technical Data) - Gemma - Saudi Media System
TEH-00-000-6A-MA-MP-8316 Rev.01

With reference to the Data/Telephone System Equipment Rack (Technical Data) - (Gemma) - Saudi Media System, material submittal number ESH 00-000-6A-MA-MP-0316 Rev.01 received on May 04, 2017. Please be advised that the submittal has been reviewed and given Status "E" - **APPROVED AS SHOWN**, with the following comments below:

Prior to essential delivery, the following comments shall be finalized:

- Project Specs. Section 18720 Para 1.3 Item (B&C) & Section 18740 Para 1.3 Item (B&A) shall be submitted.
- Final submittal data's shall be submitted as per attached completion sheet.
- Material list stamped by the contractor including all items that shall be used with the product model numbers must be submitted.
- All submitted logs/governmental certificates to be reviewed, where applicable and to remain valid during the project life cycle.

Note:
As per MOI Letter Ref. 6027 dated 14/07/2017, Contractors have to adhere to the following:
A. Contractors should submit (three (3)) Suppliers and Manufacturers for each material or equipment, as per Contract Particular Conditions Clause (P1) and Clause (P3) Item (30.2).
B. Local Manufacturers have the priority and shall prevail, as per Contract General Conditions Clause (G12) Item (12.2.1) and Ministerial Decree no. 42539 dated 6/4/1435 H.
C. Each Material should be supplied to each site by One Manufacturer/Supplier only.

Disclaimer: This conditional approval will be subjected to verification for compliance with the applicable comments and all relevant terms and conditions of the contract. This note 'E' approval does not relieve the contractor of ANY obligation under the contract and is independent of any future review and submitted approval design.

This is for your information and relevant action.

Contractor's name:
MA / JK / JH / KS / MD / LS

17/12/2017 Page 1 of 1

CONSULTANT APPROVALS

					
PROJECT NO / رقم المشروع Work Package / حزمة الأعمال Location / الموقع		PROJECT NAME / اسم المشروع ASER REGION AL GAMMA (SI), ASER (SI) & DIAHRAN AL JANDUB (SI)		South Border Housing Project Area: SOUTHERN Discipline: ELECTRICAL	
Ref. No / رقم المرجع: SBH-08-08-AA-NA-NIP-0096 Sub. No / رقم الفرع: 3301		Rev. No: 08 Date / التاريخ: 29/01/2018 Contract No / رقم العقد: 154/3/1			
Material Description (One Item only per each form) / وصف المواد (مادة واحدة لكل نموذج) / OUT DOOR FIBER CABLE, FDT & ENCLUSERS (TECHNICAL DATA)					
Drawing Ref / مرجع المخطط: 16718 Specifications Ref / مرجع المواصفات: 16718		B.O.Q Ref No / المرجع في بيان المواصفات: SASO, ISO, ICE Standards, BS, DIN / المعايير: SASO, ISO, ICE		As Specification / حسب المواصفات: <input type="checkbox"/> Bill of Materials / بيل / <input type="checkbox"/>	
Company Name / اسم الشركة: CORNING, GAMMA Address / العنوان: P.O. BOX 96, BILADH-11421, KSA		Local Manufacturer / المصنع المحلي: C.C.A.S.G Manufacturer Production Period / فترة الإنتاج: TO SITE Delivery Ex-Works / التسليم خارج المصنع: TO SITE Total Delivery Time / إجمالي وقت التسليم: YES Overhead / التغطية: YES Sea Freight / الشحن البحري: N/A Total Freight / مجموع مدة الشحن:		Local Manufacturer / المصنع المحلي: C.C.A.S.G Manufacturer Production Period / فترة الإنتاج: N/A Delivery Ex-Works / التسليم خارج المصنع: N/A Total Delivery Time / إجمالي وقت التسليم: N/A Overhead / التغطية: N/A Sea Freight / الشحن البحري: N/A Total Freight / مجموع مدة الشحن: N/A	
Local Agent / الوكيل المحلي: HOSHAN INTEGRATED SYSTEM Programmed Date material required on site / التاريخ المتوقع للمواد المطلوبة في الموقع:		Expected date of arrival on site / التاريخ المتوقع لوصول المواد في الموقع:			
Reference: 1. SBH-08-08-AA-NA-NIP-0088 REV 00 SUBMITTAL (CODE-B) 2. SBH-08-08-AA-NA-NIP-0082 REV 00 SUBMITTAL (CODE-B)					
Contractor's Authorized Manager / مدير المشروع المصرح به: Mr. MAGDY EL SAYED BEGAYE Signature / التوقيع: [Signature] Date / التاريخ: 24/02/2018		Consultant's Comments / ملاحظات الاستشاري: (Use approved draw and release the Contractor of his obligations under the Contract and be held be liable for all cost, delays and expenses by the subcontractor) Refer to attached comments			
Status / الحالة: <input type="checkbox"/> A - APPROVED / <input checked="" type="checkbox"/> B - APPROVED AS NOTED / <input type="checkbox"/> C - REVISE & RESUBMIT / <input type="checkbox"/> D - REJECTED / <input type="checkbox"/> B - REJECTED					
Contractor's Representative / ممثل الشركة: Michael Azmy Signature / التوقيع: [Signature] DATE / التاريخ: 3/12/2018		Consultant Project Manager / مدير المشروع الاستشاري: Hosam Abdou Signature / التوقيع: [Signature] DATE / التاريخ: 3/12/2018			

Kingdom of Saudi Arabia Security Planning and Development Agency - KAP4 Project PROGER		RTCC	
Ministry of Interior PROGER Engineering & Management Project Name: General Directorate of Admin Investigation Project No: 162 Title: Project Manager - Proger Head Office		Submittal No: KAP4 - MAT - 102 - 000X - TT - 0013 E Date: 30-Mar-17	
Document / Material Submittal			
Description: <input type="checkbox"/> Civil <input type="checkbox"/> Arch <input type="checkbox"/> Inter <input type="checkbox"/> Mech <input type="checkbox"/> Elec Submitted For: <input checked="" type="checkbox"/> Approval <input type="checkbox"/> Information <input type="checkbox"/> Review <input type="checkbox"/> Site Use			
Attachments: <input type="checkbox"/> Sample <input checked="" type="checkbox"/> Catalogue / Manuals <input type="checkbox"/> Compliance Cert <input type="checkbox"/> Manufacturer Data & Specification <input type="checkbox"/> Drawings <input type="checkbox"/> Procedures <input type="checkbox"/> Spare Parts List <input type="checkbox"/> Calculation Sheet <input type="checkbox"/> Others/Specify:			
Item Description IP TELEPHONY AND DATA SYSTEM (Cabinet Rack - 22U)		No. of Submittals: 1	
Document / Material Description IP TELEPHONY AND DATA SYSTEM (Cabinet Rack - 22U)		Reference Specs # 2P 16718	
Supplier Data Name: EBTIKAR TECHNOLOGY CO. LTD. Address: P.O. Box 52006, Riyadh 11573, Kingdom of Saudi Arabia			
Manufacturer Data Name: GAMMA Factory for Metal Industries Address: Riyadh, Kingdom of Saudi Arabia			
Samples Samples Description Remarks:			
To be used for: the whole Project location as per Approved Design Drawing and relevant specifications.			
Engineer's Note: to enter Action Codes, Remarks and return to Contractor. Remarks: ACTION CODE B Gamma Factory for Metal Industries / Ebtikar Technology Co. Ltd are approved as manufacturer/integrator & supplier respectively.			
Action: <input type="checkbox"/> A - APPROVED AS SUBMITTED / <input checked="" type="checkbox"/> B - APPROVED AS NOTED / <input type="checkbox"/> C - REVISE AND RESUBMIT / <input type="checkbox"/> D - REJECTED / <input type="checkbox"/> E - FOR INFORMATION			
For Engineer's Use: Review By: Eng. Sara's Al Mulla DATE / التاريخ: 30-April-2017		Supervisor/Manager: Name / Title: Eng. Francesco Clemente DATE / التاريخ: 30-April-2017	

Kingdom of Saudi Arabia Ministry of Interior PROGER Engineering & Management		RTCC	
Project Name: South Border Housing Project Work Package: JAZAN A Location: SA, SIB & SII		Project No: P133 Discipline: ELECTRICAL	
MATERIAL SUBMITTAL			
Ref. No / رقم المرجع: SA-MB-E-REV-0102 Sub. No / رقم الفرع: ARCHEN		Rev. No: 01 Date / التاريخ: 28-Dec-16 Contract No / رقم العقد: US/SM/147	
Material Description (One Item only per each form) / وصف المواد (مادة واحدة لكل نموذج) / NATV System			
Drawing Ref / مرجع المخطط: N/A Specifications Ref / مرجع المواصفات: 16785		B.O.Q Ref No / المرجع في بيان المواصفات: N/A Standards, BS, DIN / المعايير: N/A	
Company Name / اسم الشركة: Gamma		Local Manufacturer / المصنع المحلي: C.C.A.S.G Manufacturer Production Period / فترة الإنتاج: N/A Delivery Ex-Works / التسليم خارج المصنع: N/A Total Delivery Time / إجمالي وقت التسليم: N/A Overhead / التغطية: N/A Sea Freight / الشحن البحري: N/A Total Freight / مجموع مدة الشحن: N/A	
Local Agent / الوكيل المحلي: HOSHAN INTEGRATED SYSTEM Programmed Date material required on site / التاريخ المتوقع للمواد المطلوبة في الموقع:		Expected date of arrival on site / التاريخ المتوقع لوصول المواد في الموقع:	
Reference: 1. SBH-08-08-AA-NA-NIP-0088 REV 00 SUBMITTAL (CODE-B) 2. SBH-08-08-AA-NA-NIP-0082 REV 00 SUBMITTAL (CODE-B)			
Contractor's Authorized Manager / مدير المشروع المصرح به: Mr. MAGDY EL SAYED BEGAYE Signature / التوقيع: [Signature] Date / التاريخ: 24/02/2018		Consultant's Comments / ملاحظات الاستشاري: (Use approved draw and release the Contractor of his obligations under the Contract and be held be liable for all cost, delays and expenses by the subcontractor) Refer to attached comments	
Status / الحالة: <input type="checkbox"/> A - APPROVED / <input checked="" type="checkbox"/> B - APPROVED AS NOTED / <input type="checkbox"/> C - REVISE & RESUBMIT / <input type="checkbox"/> D - REJECTED / <input type="checkbox"/> B - REJECTED			
Contractor's Representative / ممثل الشركة: Michael Azmy Signature / التوقيع: [Signature] DATE / التاريخ: 25/12/2016		Consultant Project Manager / مدير المشروع الاستشاري: Hosam Abdou Signature / التوقيع: [Signature] DATE / التاريخ: 25/12/2016	

Southern Border Housing Project

A
A.S.C.B.H.N

Data/Telephone System Equipment Rack (Technical Data) – Gamma – Small Media System
SEM-00-000-AA-NA-MP-0316 Rev.01

With reference to the Data/Telephone System Equipment Rack (Technical Data) – (Gamma) – Small Media System, technical document number SEM-00-000-AA-NA-MP-0316 Rev.01 received on May 04, 2017 Please be advised that the submittal has been reviewed and given Status **“B – APPROVAL AS NOTED”** with the following comments below:

Note: In essential delivery, the following comments shall be finalized:

- Project Specs. Section 18720 Para 1.3 Item (B&C) & Section 18740 Para 1.3 Item (B&C) shall be submitted.
- For calculation details shall be submitted as per attached compliance sheet.
- Material list stamped by the contractor including all items that shall be used with the product model numbers must be submitted.
- All submitted logs/governmental certificates to be renewed, where applicable and to remain valid during the project life cycle.

Note:
 As per MOI Letter Ref. 6027 dated 14/07/2017 H, Contractors have to adhere to the following:

- Contractors should submit (three (3)) Suppliers and Manufacturers for each material or equipment, as per Contract Particular Conditions, Clause (D7) and Clause (E3) from (30.2).
- Local Manufacturers have the priority and shall prevail, as per Contract General Conditions Clause (B12) Item (12.2.1) and Ministerial Decree no. 42559 dated 6/4/1435 H.
- Each Material should be supplied to each site by One Manufacturer/Supplier only.

Disclaimer: This conditional approval will be subjected to verification for compliance with the applicable comments and all relevant terms and conditions of the contract. This note "B" approval does not relieve the contractor of ANY obligation under the contract and is independent of any future review and submitted approval design.

TNA is for your information and relevant action.

Contractor's comment:

MA / JK / JS / KS / MD / LY

07/09/2017 Page 1 of 1

R-IN-21332

Kingdom of Saudi Arabia
Security Planning and Development Agency - KAP4 Project

PROGER Engineering & Management RTCC
 Ministry of Interior PROGER Engineering & Management Al Rashid Trading & Contracting

Project Name: General Directorate of Passport Submittal No: RPKA - MAT 111 - RXXX - TT - 2013 - 6
 Project No: 111 RPKA - MAT 111 - RXXX - TT - 2013 - 6
 To: Project Manager - Proger Head Office Date: 26-Apr-16

Document / Material Submittal

Discipline: <input type="checkbox"/> Civil <input type="checkbox"/> Arch <input type="checkbox"/> Inter <input type="checkbox"/> Mech <input type="checkbox"/> Elec	Submitted For: <input checked="" type="checkbox"/> Approval <input type="checkbox"/> Information <input type="checkbox"/> Review <input type="checkbox"/> Site Use
Attachment: <input checked="" type="checkbox"/> Sample <input type="checkbox"/> Catalogue / Manual <input type="checkbox"/> Compliance Cert. <input type="checkbox"/> Manufacturer Data & Specification	<input type="checkbox"/> Drawings <input type="checkbox"/> Procedures <input type="checkbox"/> Spare Parts List <input type="checkbox"/> Calculation Sheet <input type="checkbox"/> Other/Specify: <input type="checkbox"/>
Item Description	
IP TELEPHONY AND DATA SYSTEM (CABINET RACKS)	No. of Submittals: 3
Document / Material Description	Reference Space #: 2F-16716
IP TELEPHONY AND DATA SYSTEM (CABINET RACKS)	

Supplier Data

Name: GAMMA	P.O. Box: Riyadh Kingdom of Saudi Arabia
Manufacturer Data	
Name: GAMMA Factory for Metal Industries	
Address: Riyadh, Kingdom of Saudi Arabia	
Sample: DOWN FIVE TELECOM CABINET	
Sample Description: 	
Remarks: 	
To be used for: the photo copied material as per approved design drawing and relevant specification.	
For Contractor (Name / Title / Signature / Date): Engr. Mohammed Al Zuhairi Deputy General Manager	

Engineer's Req. to enter Action Codes, Remarks and return to Contractor.
Remarks: ACTION CODE B

Approval is subject to our comments on the attached sheet *Muhammad Al...*

Action:	<input type="checkbox"/> APPROVED AS SUBMITTED	<input type="checkbox"/> APPROVED AS NOTED	<input type="checkbox"/> REVISE AND RESUBMIT
	<input type="checkbox"/> SELECTED	<input type="checkbox"/> FOR INFORMATION	

Contractor's Date: **27-April-2016** Engineer's Date: **27-April-2016**
 Eng. Bana Al *Bana Al...* Eng. Francesco Clemente *Francesco Clemente*

400019A1

RECEIVED

02 JUN 2016

400019A1

تقديم نموذج
 رقم النموذج: 100P00/00/14-15/1144 90
 التاريخ: 14/02/2015
 رقم الطلب: 40001659
 رقم الترخيص: 10 MAR 2015

Kingdom of Saudi Arabia
 Security Planning and Development Agency - KAP3 Project
PROGER Engineering & Management
 Saudi Binladin Group

Ministry of Interior
 PROGER Engineering & Management
 Saudi Binladin Group

Prototype: 1000a Site: General
 Title: Interrogation and Detention Audio Visual system
 Submitted No.: MAT - Gen - T - 0043
 Rev: 1
 # of Copies: 3
 Date: 10/9/2015

MATERIAL SUBMITTAL

Attachments: Sample Catalogue / Manuals Compliance Cert. Manufacturer Data & Specs
 Drawings Procedures Spare Parts List Calculation Sheet Others/Specify (CD)

Submitted for: Approval Information As Requested

Material Description	Manufacturer / Supplier Identification	Reference Specs #
Interrogation and Detention Audio Visual system	Manufacturer: Varied Supplier: <input type="checkbox"/>	Reference Standards #

To be used for: Interrogation and Detention Audio Visual system

For Contractor:

Material Manager: Hayes Solomon	Signature: _____	Date: 10/9/2015
QA/QC Mgr: Sheel Shetty	Signature: _____	Date: 10/9/2015
Dist. Control Mgr: Muhammad Radwan	Signature: _____	Date: 10/9/2015

Engineer's Reg. to enter Action Codes; Remarks and return to Contractor.

APPROVED AS SUBMITTED
 REJECTED
 APPROVED AS NOTED
 FOR INFORMATION ONLY
 REVISE AND RESUBMIT

Review By: **Hayes Solomon**
 Name: _____ Signature: _____ Date: 10/9/2015
 Name: _____ Signature: _____ Date: _____

Kingdom of Saudi Arabia
 Ministry of Interior
 Security Planning and Development Agency - KAP3 Project
PROGER Engineering & Management

MATERIAL APPROVAL - CHECK LIST

KAP 3	MODEL NO.	ALL	SITE NO.	---
CONTRACTOR SUBMISSION NO.	MAT-GEN-T0043		REV. NO.	01
DISCIPLINE	Low Current		DESIGN PHASE	Detailed Typological Design
MATERIAL DESCRIPTION	Audio/Visual System (Detention & Interrogation) - 1-23			

LIST OF ITEMS

ITEMS TO BE CHECKED	CHK	NOTES
PRODUCTS Submittal number, date and revision number from three manufacturers including: a. product name (or description); b. indication of referenced specifications; c. indication of related item in the B.O.Q. Indication of location of using material and sketch (if necessary). Manufacturer profile including name, contact details, reference list, country of origin, ISO and other certificates, etc. Supplier profile including name, contact details, previous projects, ISO certificates and local certificates: - Industrial license; - Zakat certificate; - OOSI certificate; - Commercial registration certificate; - Ministry of Labor certificate. Material list including name (or description), model number, major data, quantities, country of origin (manufacturing location) and any other important comments. Copy of related technical specification as per contract documents attached Compliance sheet (comparison sheet between contract specification and manufacturer/supplier's proposed specification) stamped by the manufacturer/supplier. Compliance has to be specified for each item. Compliance has to be specified in the related technical clause and sub-clause in the related technical specification with reference to the catalogue/technical data sheet. Any deviation from related technical specification, if existing, has to be clearly mentioned.	<input checked="" type="checkbox"/> xx <input type="checkbox"/> <input type="checkbox"/> <input type="checkbox"/> <input checked="" type="checkbox"/> <input checked="" type="checkbox"/> <input checked="" type="checkbox"/>	Contractor has to submit another manufacturer/supplier related to same material as per contract documents. Not submitted Not submitted Ref. to remarks #2,4,5,6,7 Refer to remark #1,2

KAP3-CHK-MAT-00-0000-TT-0043-B

Kingdom of Saudi Arabia
Ministry of Interior
Security planning and development Agency
KAP3 Project

MATERIAL APPROVAL - CHECK LIST

KAP 3	MODEL NO.	ALL	SITE NO.	---
CONTRACTOR SUBMISSION NO.	MAT-GEN-T0043		REV. NO.	01
DISCIPLINE	Low Current		DESIGN PHASE	Detailed Typological Design
MATERIAL DESCRIPTION	Audio/Visual System (Detection & Interrogation) - [] - 2/3			

LIST OF ITEMS		
ITEMS TO BE CHECKED	CHK	NOTES
Certificates of compliance with local and international codes and standards	<input checked="" type="checkbox"/>	Refer to remark #10
Indication of warranty period as per contract documents	<input checked="" type="checkbox"/>	Refer to remark #11
Technical data sheets and catalogues (one original catalogue to manufacturer)	<input checked="" type="checkbox"/>	Copy
Operation and maintenance manuals as per contract documents	<input checked="" type="checkbox"/>	
Approvals of local authorities having jurisdiction, if required	<input type="checkbox"/>	
Manufacturer installation details recommendations and instructions	<input type="checkbox"/>	
Factory routine test certificates and third party test certificates, if required	<input type="checkbox"/>	
Time schedule for Materials submittal (approved by PROGER) showing all material and its planned submittal dates attached	<input type="checkbox"/>	Not provided, contractor has also to indicate the date of submittal for each supplier/manufacturer if they (at least three) are not submitted together.
Suitability of the operating temperature of the product in reference to environmental factors of the site, if required	<input checked="" type="checkbox"/>	
SAMPLE CATEGORIES		
Submission of one samples board for each manufacturer/supplier, if possible	<input type="checkbox"/>	Refer to remark #12
Indication of manufacturer name, contact details and country of origin for each sample	<input type="checkbox"/>	
Indication of suppliers name, contact details and country of origin for each sample	<input type="checkbox"/>	
Indication of sample name and model number below each sample on the board (they have to be securely fixed)	<input type="checkbox"/>	
REMARKS		
1. Reference for the submitted material is RF1 # E0014 dated 2 nd August 2015 approved by Client on 0 th August 2015 without any V.O. or extra cost with all complementary components.		

KAP3-CHK-MAT-00-0000-TT-0043-B pag. 2

Kingdom of Saudi Arabia
Ministry of Interior
Security planning and development Agency
KAP3 Project

MATERIAL APPROVAL - CHECK LIST

KAP 3	MODEL NO.	ALL	SITE NO.	---
CONTRACTOR SUBMISSION NO.	MAT-GEN-T0043		REV. NO.	01
DISCIPLINE	Low Current		DESIGN PHASE	Detailed Typological Design
MATERIAL DESCRIPTION	Audio/Visual System (Detection & Interrogation) - [] - 2/3			

LIST OF ITEMS		
ITEMS TO BE CHECKED	CHK	NOTES
2. NTSC shall be used instead of PAL according to the submitted manufacturer recommendation letter.		
3. Remote keypad accessories shall be included for desk/stand mounted or surface mounted box. Multi-viewer magnetic mounted (stand shall be specified) location to be specified on submitted drawings.		
4. Item #7 and #8, shall be as per submitted updated material list.		
5. Item #11 in the material list shall be as per submitted updated material list. Cabinet size shall be consistent with its all components.		
6. Submitted devices shall include power supply. Power vmp included in the submitted rack.		
7. Submitted Multi track audio recorder ICE-16 is with 16 input. Contractor is responsible to provide other multitrack or acceptable solution if submitted 16x16 not enough without any additional cost or V.O.		
8. For the Submitted MICs, ceiling/lattice ceiling, ceiling height and cable length (attenuation, cable in one piece) shall be consider for Mic sensitivity. Coordination with other disciplines is required. Submitted MICs are not appropriate to be install in concrete ceiling (contractor responsibility). Vandal proof shall be consider for the detention areas.		
9. Compatibility and integration is contractor responsibility for system components.		
10. ISO certificates, system components certificates manufacturer and supplier governmental certificates are missing.		
11. Warranty letters shall be submitted by contractor and manufacturer without any conditions with 10years spare parts letter.		
12. Sample board and CD with softcopy not submitted.		
13. Refer to attached updated docs.		

KAP3-CHK-MAT-00-0000-TT-0043-B pag. 3

Kingdom of Saudi Arabia
Ministry of Interior
Security planning and development Agency
KAP3 Project

MATERIAL APPROVAL - CHECK LIST

KAP 3	MODEL NO.	ALL	SITE NO.	---
CONTRACTOR SUBMISSION NO.	MAT-GEN-T0043		REV. NO.	01
DISCIPLINE	Low Current		DESIGN PHASE	Detailed Typological Design
MATERIAL DESCRIPTION	Audio/Visual System (Detection & Interrogation) - [] - 2/3			

LIST OF ITEMS		
ITEMS TO BE CHECKED	CHK	NOTES
SUBMISSION FINAL RESULT (CODE)		
A - APPROVED AS SUBMITTED <input type="checkbox"/> B - ACCEPTED EXCEPT AS NOTED <input checked="" type="checkbox"/> C - REVISE AND RESUBMIT <input type="checkbox"/> D - REJECTED <input type="checkbox"/>		
REVIEWED BY	W. Hassan	SIGNATURE DATE 21/08/2015
CHECKED BY	G. Papano	SIGNATURE DATE 21/08/2015
APPROVED BY	M. Geraha	SIGNATURE DATE 5/9/15

KAP3-CHK-MAT-00-0000-TT-0043-B pag. 4

CONSULTANT APPROVALS

Ministry of Interior MIFON PROJECT		MIFON Project MIFON - 03	
Document Submittable Acceptance Form			
Document Title	Racks 9-12-15U		
Submittal No.	405	Rev. No.	3
Date:	6/4/2016		
Type of Submittal:	<input type="checkbox"/> New <input checked="" type="checkbox"/> Revision <input type="checkbox"/> Re-Submittal		
From:	To:		
MOI			
Comments			
GAMMA approved as below comments:			
1. All Racks should be black color. 2. All Racks should be dimensions 600x600mm for all sizes. 3. The Rack size definition depend on the survey and site conditions. 4. Door should be metal and perforated. 5. Wall mounted in 15U only, any higher sized should be stand fixed. 6. Side removable is recommended. 7. Upper Fan's should be installed.			
Project Manager:			
Signature: 			
Approval Code			
A	Approved	C	Re-Submit
B	Approved as noted	D	Rejected

Kingdom of Saudi Arabia Security Planning and Development Agency - KAP4 Project		RTCC	
PROGER		RTCC	
Ministry of Interior			
Project Name:	General Directorate of Admin Investigation	Submittal No.	405
Project No.:	142	KAP4 No.:	102-2000-11-2017-8
To:	Project Manager - Proger Head Office	Date:	20-Oct-17
Document / Material Submittal			
Description:	<input type="checkbox"/> Civil <input type="checkbox"/> Arch <input type="checkbox"/> Steel <input type="checkbox"/> Mech <input checked="" type="checkbox"/> Elec		
Submittal For:	<input checked="" type="checkbox"/> Approval <input type="checkbox"/> Information <input type="checkbox"/> Review <input type="checkbox"/> Site Use		
Attachments:	<input type="checkbox"/> Sample <input type="checkbox"/> Catalogue / Manuals <input type="checkbox"/> Compliance Cert <input type="checkbox"/> Manufacturer Data & Specification		
<input type="checkbox"/> Drawings <input type="checkbox"/> Procedures <input type="checkbox"/> Open Parts List <input type="checkbox"/> Calculation Sheet <input type="checkbox"/> Others (Specify):			
Item Description		No. of Submittals	2
IP TELEPHONY AND DATA SYSTEM - CABINET RACKS (Alternative Supplier)		Submittal No.	2
Document / Material Description		Reference Specs #	
IP TELEPHONY AND DATA SYSTEM - CABINET RACKS (Alternative Supplier):			2P 16716
1. 43U - 800 x 1000			
2. 43U - 800 x 800			
3. 23U - 800 x 800			
4. 9U - 800 x 800			
5. 9U - 800 x 1000			
Supplier Data			
Name:	Global Business Solutions		
Address:	Office #13, 4th Floor Al Mousa Tower, North Complex, Choue Street, Riyadh, K.S.A.		
Manufacturer Data			
Name:	GAMMA Factory for Metal Industries		
Address:	P.O. Box 288225, Riyadh 11585, Kingdom of Saudi Arabia		
Supplier Description:	Reference Approved: KAP4 807 102 2000 11 2017 8		
To be used for:	For whole Project (subject to per Approved Design, Drawing and material specification)		
For Contractor: (Name / Title / Signature)			
Engineer's Note: to enter Action Codes, Remarks and return to Contractor.			
Remarks: ACTION CODE: B			
(Cabinet Racks) Cabinet Racks are approved subject to 42 U 800 W x 1000 D mm perforated double door on front and back, for main communication equipment in main communication room. Cabinet Racks 42 U 800x800 mm, 23U 800x800 mm, 9U 800x800 mm, 9U 800x1000 mm, perforated double door on front and perforated single door on back for additional communication rooms.			
ACTION: <input type="checkbox"/> APPROVED AS SUBMITTED <input checked="" type="checkbox"/> APPROVED AS NOTED <input type="checkbox"/> REVISION AND RESUBMIT <input type="checkbox"/> REJECTED <input type="checkbox"/> FOR INFORMATION			
For Engineer's Use:			
Review By:	Eng. Mujahid Alshaykh	Review Date:	29-Oct-2017
Checked By:	Eng. Afham Desouki	Checked Date:	29-Oct-2017
Name:	Eng. / Title	Signature / Stamp	Date
			

المملكة العربية السعودية
الهيئة العامة للغذاء والدواء
(111)

الرقم: 111 / / التاريخ: 11 / 11 / 2017

المشروعات: 133780

الرجوع: بشأن تغيير نوعية طاولات الحاسب الآلي لمشروع إنشاء المعهد العالي للتدريب والتقني بالرياض.

المستلمين / مكتب المعمور مهندسون استشاريون
ص.ب 11117
الرياض 11174
فاسكس: 011/1717610

إشارة ان خطابكم رقم 898 / 2016 / بتاريخ 23 / 02 / 1438 هـ بشأن تغيير طاولات الحاسب الآلي لمشروع إنشاء المعهد العالي للتقنيات المتقدمة بالرياض إشرافكم تفيدكم بأنه لا مانع من تغيير الطاولات المعتمدة من نوع LANDE إلى نوع GAMMA مع الالتزام بالأحجام والمقاسات في خطاب الاعتماد ، على أن يتحمل المشاور الرئيسي مسؤولية التأخير والله يحفظكم

مدير عام الإدارة العامة
المشاور العام
م / هشام بن علي الجسارني

www.rfcc.gov.sa

ص.ب 8422 الرياض 11572 - شارع الوشم - سترال 2811111 - فاكس: 106876

HARMAIN SHAREEFAIN DEVELOPMENT OF SECURITY CENTERS - KAPOI
Supplier Pre-Qualification Submittal
 تقديم أهلية مورد

Project No: 22 Mar 2018
 Project Name: HARMAIN SHAREEFAIN DEVELOPMENT OF SECURITY CENTERS - KAPOI

Company Name: [Blank]
 Address: [Blank]

Handwritten notes in Arabic:
 هذا النموذج من أجل تقديم أهلية المورد للمواد التي سيتم استخدامها في المشروع. يجب أن يكون المورد قادرًا على توفير المواد المطلوبة في الوقت المحدد وبالجودة المطلوبة. يجب أن يكون المورد قادرًا على توفير الدعم الفني اللازم للمشروع.

Data & Telephone BoQ

المورد: [Blank]
 اسم المورد: [Blank]
 رقم الهاتف: [Blank]
 عنوان المورد: [Blank]

Item	QTY	Unit	Rate	Total
1. 2.000000	2.000000	Lot	10000	20000
2. 1.000000	1.000000	Lot	5000	5000
3. 1.000000	1.000000	Lot	5000	5000
4. 1.000000	1.000000	Lot	5000	5000
5. 1.000000	1.000000	Lot	5000	5000
6. 1.000000	1.000000	Lot	5000	5000
7. 1.000000	1.000000	Lot	5000	5000
8. 1.000000	1.000000	Lot	5000	5000
9. 1.000000	1.000000	Lot	5000	5000
10. 1.000000	1.000000	Lot	5000	5000

Handwritten notes in Arabic:
 لديكم من إمداد جميع مواد الشركة فائده كما تفضل
 بتوفير المواد المطلوبة في الوقت المحدد وبالجودة المطلوبة
 ولتفضلوا بالتوقيع على هذا النموذج وتقديمه للمهندس المشرف

PROJECT: THE CURSE
MATERIAL SUBMITTAL FORM (MSMF)
 STRUCTURED CABLING NETWORK (SCN) (Cable Cabinet)

Manufacturer: GAMMA
 Address: KSA
 Phone: 01144888888

Handwritten notes:
 Construction Manager's Client Comments: of size and DIM must be checked at 230/100
 * Supplier will be fully responsible about the dimension of Cabinet and dimension of Rack. In case of any changes the supplier will not claim charges for any delay work.

Handwritten notes:
 Read with above comment for compliance.
 20. 2/15
 Mon. 2:45 PM

RADISSON BLU HOTEL
AL KHOBAR, KSA

MATERIAL SUBMITTAL FORM

Client: MEP Contractor: Consultant:

Purpose of Submittal:
 FOR APPROVAL
 FOR REVIEW & COMMENTS
 FOR INFORMATION/REFERENCE
 OTHERS

Submittal No.: ELMS-011
 Date: April 27, 2016
 Revision: 2

Work Area:
 BUILDING
 INFRASTRUCTURE
 ARCHITECT
 CIVIL
 ELECTRICAL/ELECTRONIC CURRENT
 MECHANICAL
 SANITARY
 APPLIANCES

ITEM	MATERIAL DESCRIPTION	REMARKS
1	NETWORKING & TELECOMMUNICATIONS CABINET RACKS GAMMA - FREE STANDING CABINETS - 4RU GAMMA - WALL MOUNTED CABINETS - DOUBLE SECTION WALL MOUNT GAMMA - ENCLOSURES - INDOOR & OUTDOOR TYPE MANUFACTURED BY GAMMA FACTORY FOR METAL BLD., U.S.A. COMPLIANCE/STANDARDS - IEC-210 D, ISO STANDARDS XXXXXXX NOTHING FOLLOWS XXXXXX	For Networking, Telecommunications and Low Current applications. Metal enclosures for electrical and low current applications as required.

Attachment:
 CATALOGUE
 SPECIFICATION
 PICTURE
 DRAWING
 SAMPLE

Consultant Remarks:
 Supply and installation according to approved shop drawing and specification.

Submittal Status:
 CODE:
 A. Approved (Work may proceed)
 B. Approved as noted (Work may proceed) subject to incorporation of changes indicated.
 C. Approved as noted (Review & Resubmit)
 D. Disapproved (Review & Resubmit) Work may not proceed.

MEP Contractor:
 Name: Engr. Gamal Anis Radd
 Date: April 27, 2016

Consultant:
 Name: Ghadaab Doudou
 Date: 10/5/2016

DIYAR
Saudi Diyar Consultants

Site Staff Comments

Subject: material submitted for Battery Rack
 Received Date: 01/8/2017
 Issued Date: 06/8/2017
 Contractor: ICAD
 Project Title: land and marine perimeter security system
 Project No.: JET1827
 Attachment: Pre-qualification Catalogue, Technical data
 Trace Number: DT-ICAD-BALAW-MTS-0071
 Date: 01/8/2017

Ref. No.	Comments	Responsible Date
1	GAMMA is approved as a manufacturer for Battery Rack subject to the following conditions: 1- The warranty shall be extended to ten (10) years from the date of delivery against manufacture defects. 2- Contractor shall submit the total number of batteries with the catalogues for each location of the UPS's with the shop data for each UPS to achieve 4 hours as a back-up time for all UPS's taking in the consideration the loads of the distribution systems.	3

Name: Ahmed Ghani
 Electrical Engineer

 Date: 6/8/2017

ICS TRANSMITTAL SUBMITTAL DOCUMENT
GID UP

Project Name: GID/UP DATA CENTER, JEDDAH, KSA
 Project No.: A12101
 Contractor: ICS
 Designer: J/FA
 To: GID (PMO PROGRAM MANAGER)
 Copy:

Attachment No.: 1
 Submittal Date: 30-Oct-17
 Review Submittal: -
 Review Date: -

PURPOSE OF SUBMITTAL:
 For Information
 For Comment
 For Approval

DISCIPLINE:
 ISA
 Electrical
 Mechanical
 IT
 ICT
 Paint
 Others

ATTACHMENT:
 Catalogue
 Drawing
 Certificate
 Sample
 Tech. Data
 Calculation
 Others

Dr. No.	Submittal Reference No. / Drawing Number / Document Number	Drawing / Document Title	No. of copies	Rev. No.	Action Code
1		Access Control Material 1. Cabinet Box (GAMMA) 2. PIN Sensor 3. Magnetic Lock	1 1 1		

Contractor's Remark:
 Name: Haseeb Riaz

 Date: 30-Oct-17

GID's Remark:
 1- SINGLE MAG. LOCK MODEL (EM-301LED)
 2- DOUBLE MAG. LOCK MODEL (EM-300D LED)
 3- ALL SCREWS SHALL BE GALVANIZED. SCREEN SET (WHICH COMES WITH THE MAG. LOCKS) SHALL BE REPLACED WITH GALVANIZED SCREENS.

GID's Representative:
 Name: KHAMMAM HADJI
 Position: PRG-MGR
 Date: 01-NOV-2017

Action Code:
 A. APPROVED
 B. APPROVED AS NOTED
 C. RETURN

REF. IN: _____ Signature: _____ Date: _____
 REF. OUT: _____ Signature: _____ Date: _____

CONSULTANT APPROVALS

شروع طلب الترخيص الإجمالي بالرقم
شركة استشارات الهندسة

AD
التجارة العامة

REQUEST FOR SAMPLE APPROVAL

Item No: 22-23-24
Material spec: 106-U42
Quantity As Contract

المصنع: مصنع جيتا للمعدات المعدنية
العنوان: الرياض صندوق بريد 390395
الهاتف: 00966-0012428536
جودة الاتصال: مطلوب

الفنس: 00966-112428538

نوع التقييم:
Arch. إنشائي
Mech. ميكانيكي
Elect. كهربائي
Others آخري

التعليقات:
Catalog كاتالوج
Draw. مخطط
Lithum لوحة
Samples نماذج
Other آخري

نتيجة الموافقة على مواصفات العقد نظر مستشاري المقرول
اسم و توقيع مدير المشروع الموافق: م | علي | الترخيص |

RESULT:

ملاحظات وتوقيع مدير المشروع:

CONSULTANT'S PROJECT MANAGER
NAME:
SIGNATURE:
DATE:
CONSULTANT'S SPECIALIST ENGINEER
NAME:
SIGNATURE:
DATE: 04/23/2018

Owner's Stamp, Sig & Comments:

NAME:
SIGNATURE:
DATE:
The Final Decision
A موافق
B معلق مع ملاحظات
C غير موافق و يعاد

RADISSON BLU HOTEL
AL KHOBAR, K.S.A.

MATERIAL SUBMITTAL FORM

Client: MEP Contractor: Consultant: EHAFF

Purpose of Submittal:
 FOR APPROVAL
 FOR REVIEW & COMMENTS
 FOR INFORMATION REFERENCE
 OTHERS
 NEW SUBMITTAL
 RESUBMITTAL

Submittal No. ELMS-015
Date: April 27, 2018
Revision: 0

Work Area:
 BUILDING
 ARCHITECT
 ELECTRICAL/LOW CURRENT
 SHIMTRY
 INFRASTRUCTURE
 CIVIL
 MECHANICAL
 APPLIANCES

ITEM	MATERIAL DESCRIPTION	REMARKS
1	NETWORKING & TELECOMMUNICATIONS CABINET RACKS GAMMA - FREE STANDING CABINETS - 48U GAMMA - WALL MOUNTED CABINETS - DOUBLE SECTION WALL MOUNT GAMMA - ENCLOSURES - INDOOR & OUTDOOR TYPE MANUFACTURER: GAMMA FACTORY FOR METAL IND., K.S.A. COMPLIANCE/STANDARDS: EN-61320, ISO STANDARDS XXXXXX NOTHING FOLLOWS XXXXXX	For Networking, Telecommunications and Low Current applications. Metal enclosures for electrical and low current applications as required.

Attachment:
 CATALOG SPECIFICATION PICTURE DRAWING SAMPLE

Consultant Remarks:
Supply and installation according to approved shop drawing and specification.

Submittal Status:
CODE:
A Approved (Work may proceed)
B Approved as noted (Work may proceed) Subject to incorporation of changes indicated
C Approved as noted (Revised & Resubmit) Work may not proceed
D Disapproved (Revised & Resubmit) Work may not proceed

MEP Contractor: Engr. Gamal Anis Raga
Signature:
Date: April 27, 2018

Consultant: Abdelhalim Dawood
Signature:
Date: 10/23/2018

شركة استشارات الهندسة العامة
شركة استشارات الهندسة العامة

طلب الترخيص
Material Submittal / Approval Request

SUBMITTAL No.: Re-SUBMITTAL No.: Date: 2018/04/28

Project Name: مشروع إنشاء مكاتب المدينة التجارية
Site: مواد جة المعمار
Building/ Structure: مبانى سكنية
Region:

Item No: 22-23-24
Material spec: 106-U42
Quantity As Contract

المصنع: مصنع جيتا للمعدات المعدنية
العنوان: الرياض صندوق بريد 390395
الهاتف: 00966-0012428536
جودة الاتصال: مطلوب

الفنس: 00966-112428538

نوع التقييم:
Arch. إنشائي
Mech. ميكانيكي
Elect. كهربائي
Others آخري

التعليقات:
Catalog كاتالوج
Draw. مخطط
Lithum لوحة
Samples نماذج
Other آخري

نتيجة الموافقة على مواصفات العقد نظر مستشاري المقرول
اسم و توقيع مدير المشروع الموافق: م | علي | الترخيص |

RESULT:

ملاحظات وتوقيع مدير المشروع:

CONSULTANT'S PROJECT MANAGER
NAME:
SIGNATURE:
DATE:
CONSULTANT'S SPECIALIST ENGINEER
NAME:
SIGNATURE:
DATE: 04/23/2018

Owner's Stamp, Sig & Comments:

NAME:
SIGNATURE:
DATE:
The Final Decision
A موافق
B معلق مع ملاحظات
C غير موافق و يعاد

PRODUCT CATALOGUE 2025



www.gamma.com.sa

SAUDI MADE  صناعة سعودية

رؤية VISION 2030
المملكة العربية السعودية
KINGDOM OF SAUDI ARABIA



◆ GAMMA NET WALL MOUNT RACK CABINETS

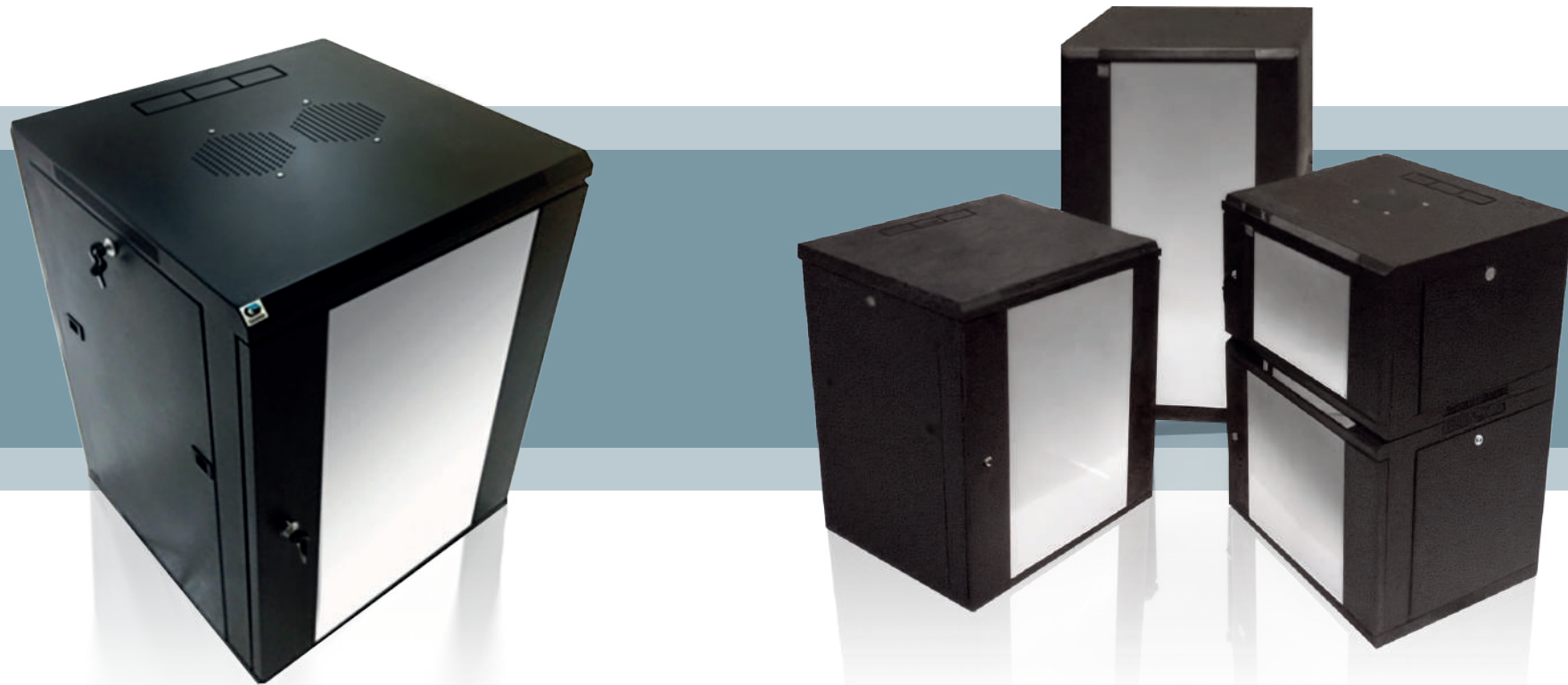

◆ GAMMA NET WALL MOUNT RACK CABINETS (600 X 450)

◆ Standard Dimensions :

Height : 6U-9U-12U-15U-18U-21U

Width : 600

Depth : 450 mm

◆ Standard Colour :

RAL 9005
BLACK



RAL 7035
Light Gray



Other colours available
on request



◆ Complying with International Standards:

- ISO 9001-2015
- ISO 14001:2015
- EIA/ECA- 310 E & EIA-310 D
- IEC 297-1 19" MOUNTING
- IEC 297-2 Overall cabinet dimensions
- IP42 Protected
- MADE IN KSA



◆ GAMMA WALL MOUNTED SINGLE SECTION

› Features:

- Wall Mount Cabinet single Section .
- Made from Welded Steel .
- Front Glass door With Key Lock – (Perforated front door available on request)
- Removable Side Doors with key lock
- Cable Inlet at top and Bottom
- 2 Pair of 19" Mounting Rails depth Adjustable
- 1 Fan 100 cfm/Fan
- IP 20 Rated (NEMA 12 –IP55 available as optional on request)
- Color BLACK RAL 9005 , or Grau 7035 , other colors available on request
- Depth : 450 mm
- Static load 40 kg
- All Keys are alike
- **MADE IN SAUDI ARABIA**



GAMMA NET WALL MOUNT RACK CABINETS (6U-9U-12U-15U-18U-21U)

Part Number	Description - Standard Configuration - Colour Black RAL 9005 (WELDED STRUCTURE)	Width (W) mm	Depth (D) mm	Height (H) mm	Depth Rail to Rail (mm)	Static Load (KG)
GMC-WMS-6U-645-1F	Gamma Net Wall Mount Cabinet 6U 600×450 with Removable Side Door , Front Glass , 2 pair of 19" Adjustable Pillars 1 Fan	600	450	365	350	40
GMC-WMS-9U-645-1F	Gamma Net Wall Mount Cabinet 9U 600×450 with Removable Side Door , Front Glass , 2 pair of 19" Adjustable Pillars 1 Fan	600	450	495	350	40
GMC-WMS-12U-645-1F	Gamma Net Wall Mount Cabinet 12U 600×450 with Removable Side Door , Front Glass , 2 pair of 19" Adjustable Pillars 1 Fan	600	450	630	350	40
GMC-WMS-15U-645-1F	Gamma Net Wall Mount Cabinet 15U 600×450 with Removable Side Door , Front Glass , 2 pair of 19" Adjustable Pillars 1 Fan	600	450	760	350	40
GMC-WMS-18U-645-1F	Gamma Net Wall Mount Cabinet 18U 600×450 with Removable Side Door , Front Glass , 2 pair of 19" Adjustable Pillars 1 Fan	600	450	895	350	40
GMC-WMS-21U-645-1F	Gamma Net Wall Mount Cabinet 21U 600×450 with Removable Side Door , Front Glass , 2 pair of 19" Adjustable Pillars 1 Fan	600	450	985	350	40

OTHER SIZES AVAILABLE ON REQUEST

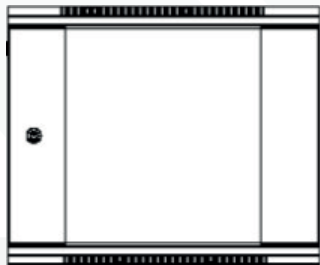

Front View

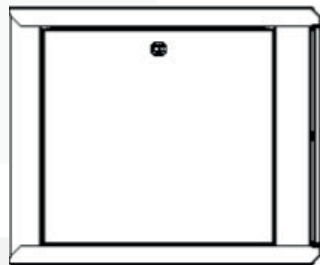

Side View

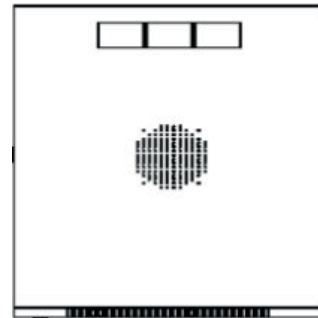

Top View

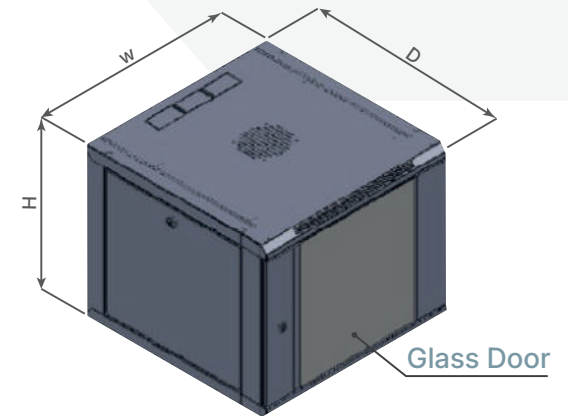

◊ GAMMA NET WALL MOUNT RACK CABINETS (600 X 600)

◊ Standard Dimensions :

Height : 6U-9U-12U-15U-18U-21U

Width : 600

Depth : 600 mm

◊ Standard Colour :

RAL 9005
BLACK



RAL 7035
Light Gray



Other colours available
on request



◊ Complying with International Standards:

- ISO 9001-2015
- ISO 14001:2015
- EIA/ECA- 310 E & EIA-310 D
- IEC 297-1 19" MOUNTING
- IEC 297-2 Overall cabinet dimensions
- MADE IN KSA

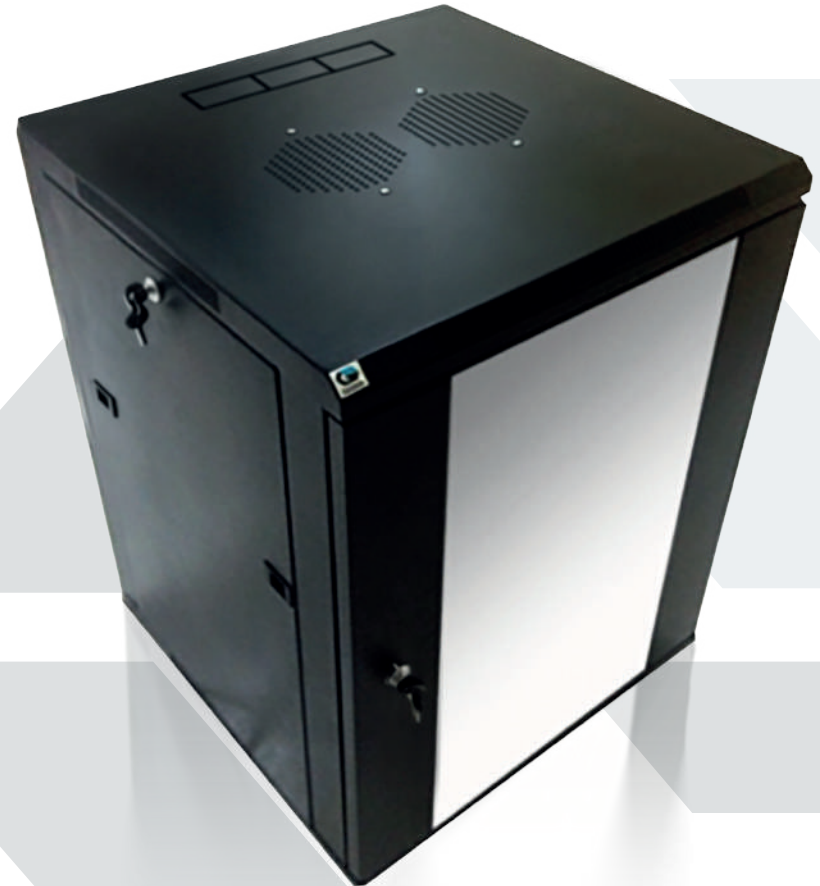

◇ GAMMA WALL MOUNTED SINGLE SECTION

› Features:

- Wall Mount Cabinet single Section .
- Made from Welded Steel .
- Front Glass door With Key Lock – (Perforated front door available on request)
- Removable Side Doors with key lock
- Cable Inlet at top and Bottom
- 2 Pair of 19" Mounting Rails depth Adjustable
- 2 Fans 100 cfm/Fan
- IP 20 Rated (NEMA 12 –IP55 available as optional on request)
- Color BLACK RAL 9005 , or Grau 7035 , other colors available on request
- Depth : 600 mm
- Static load 40 kg
- All Keys are alike
- **MADE IN SAUDI ARABIA**



GAMMA NET WALL MOUNT RACK CABINETS (6U-9U-12U-15U-18U-21U)

Part Number	Description - Standard Configuration - Colour Black RAL 9005 (WELDED STRUCTURE)	Width (W) mm	Depth (D) mm	Height (H) mm	Depth Rail to Rail (mm)	Static Load (KG)
GMC-WMS-6U-66-1F	Gamma Net Wall Mount Cabinet 6U 600×600 with Removable Side Door , Front Glass , 2 pair of 19" Adjustable Pillars 1 Fan	600	600	365	500	40
GMC-WMS-9U-66-1F	Gamma Net Wall Mount Cabinet 9U 600×600 with Removable Side Door , Front Glass , 2 pair of 19" Adjustable Pillars 1 Fan	600	600	495	500	40
GMC-WMS-12U-66-1F	Gamma Net Wall Mount Cabinet 12U 600×600 with Removable Side Door , Front Glass , 2 pair of 19" Adjustable Pillars 1 Fan	600	600	630	500	40
GMC-WMS-15U-66-2F	Gamma Net Wall Mount Cabinet 15U 600×600 with Removable Side Door , Front Glass , 2 pair of 19" Adjustable Pillars 2 Fans	600	600	760	500	40
GMC-WMS-18U-66-2F	Gamma Net Wall Mount Cabinet 18U 600×600 with Removable Side Door , Front Glass , 2 pair of 19" Adjustable Pillars 2 Fans	600	600	895	500	40
GMC-WMS-21U-66-2F	Gamma Net Wall Mount Cabinet 21U 600×600 with Removable Side Door , Front Glass , 2 pair of 19" Adjustable Pillars 2 Fans	600	600	985	500	40

OTHER SIZES AVAILABLE ON REQUEST

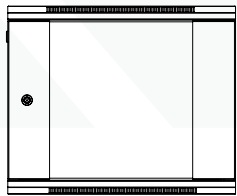

FRONT VIEW

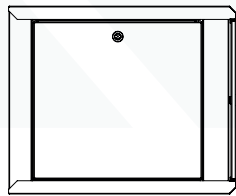

SIDE VIEW

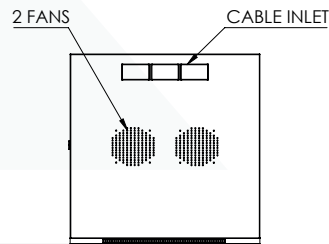

TOP VIEW

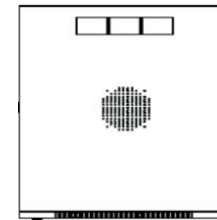
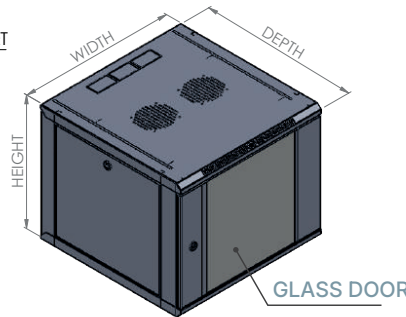

Top View

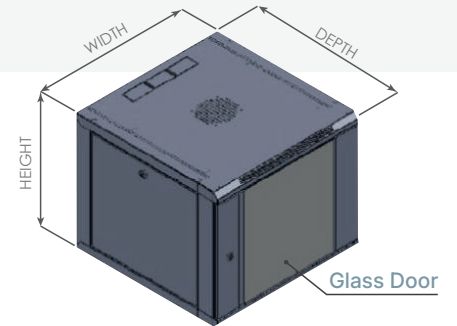

◇ GAMMA NET WALL MOUNT RACK CABINETS (600 X 800)

◇ Standard Dimensions :

Height : 6U-9U-12U-15U-18U-21U

Width : 600

Depth : 800 mm

◇ Standard Colour :

RAL 9005
BLACK



RAL 7035
Light Gray



Other colours available
on request



◇ Complying with International Standards:

- ISO 9001-2015
- ISO 14001:2015
- EIA/ECA- 310 E & EIA-310 D
- IEC 297-1 19" MOUNTING
- IEC 297-2 Overall cabinet dimensions
- MADE IN KSA



◇ GAMMA WALL MOUNTED SINGLE SECTION

› Features:

- Wall Mount Cabinet single Section .
- Made from Welded Steel .
- Front Glass door With Key Lock – (Perforated front door available on request)
- Removable Side Doors with key lock
- Cable Inlet at top and Bottom
- 2 Pair of 19" Mounting Rails depth Adjustable
- 2 Fans 100 cfm/Fan
- IP 20 Rated (NEMA 12 –IP55 available as optional on request)
- Color BLACK RAL 9005 , or Grau 7035 , other colors available on request
- Depth : 800 mm
- Static load 40 kg
- All Keys are alike
- **MADE IN SAUDI ARABIA**

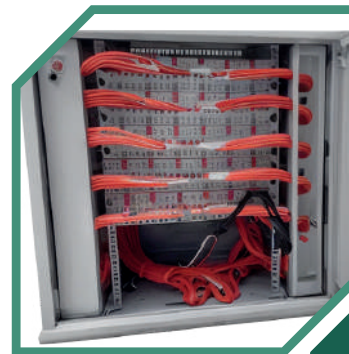

GAMMA NET WALL MOUNT RACK CABINETS (6U-9U-12U-15U-18U-21U)

Part Number	Description - Standard Configuration - Colour Black RAL 9005 (WELDED STRUCTURE)	Width (W) mm	Depth (D) mm	Height (H) mm	Depth Rail to Rail (mm)	Static Load (KG)
GMC-WMS-6U-68-2F	Gamma Net Wall Mount Cabinet 6U 600×800 with Removable Side Door , Front Glass , 2 pair of 19" Adjustable Pillars 2 Fans	600	800	365	700	40
GMC-WMS-9U-68-2F	Gamma Net Wall Mount Cabinet 9U 600×800 with Removable Side Door , Front Glass , 2 pair of 19" Adjustable Pillars 2 Fans	600	800	495	700	40
GMC-WMS-12U-68-2F	Gamma Net Wall Mount Cabinet 12U 600×800 with Removable Side Door , Front Glass , 2 pair of 19" Adjustable Pillars 2 Fans	600	800	630	700	40
GMC-WMS-15U-68-2F	Gamma Net Wall Mount Cabinet 15U 600×800 with Removable Side Door , Front Glass , 2 pair of 19" Adjustable Pillars 2 Fans	600	800	760	700	40
GMC-WMS-18U-68-2F	Gamma Net Wall Mount Cabinet 18U 600×800 with Removable Side Door , Front Glass , 2 pair of 19" Adjustable Pillars 2 Fans	600	800	895	700	40
GMC-WMS-21U-68-2F	Gamma Net Wall Mount Cabinet 21U 600×800 with Removable Side Door , Front Glass , 2 pair of 19" Adjustable Pillars 2 Fans	600	800	985	700	40

OTHER SIZES AVAILABLE ON REQUEST

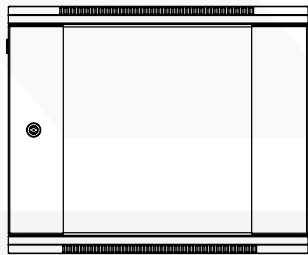

FRONT VIEW

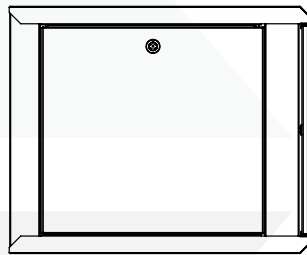

SIDE VIEW

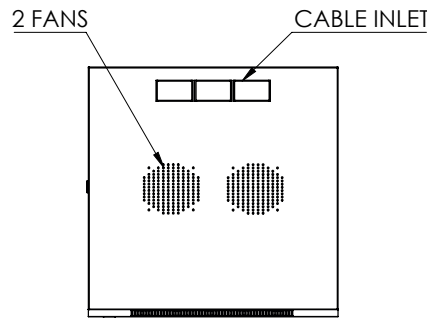

TOP VIEW

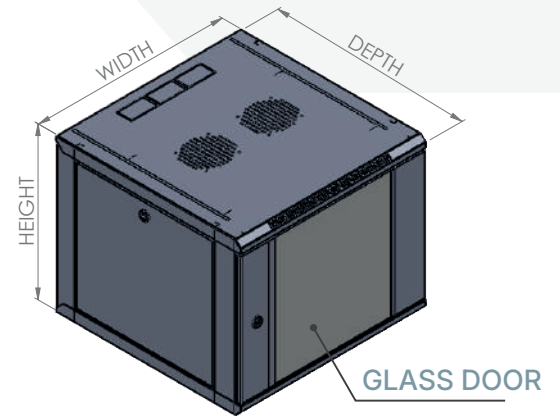

GAMMA NET FREE STAND RACK CABINETS



◆ GAMMA NET FREE STAND RACK CABINETS SECTION

› Features:

- Made from Steel Welded Frame .
- Front Glass Door with key lock (optional perforated front and back doors)
- Back door with Key lock and Ventilation
- Removable Side Doors,1 Key lock
- Cable Inlet from Top & Bottom
- 2 Fans 105 CFM/Fan , 220 Volts – (4 Fans for 1000/1200 mm depth)
- 2 Pair of 19" Mounting Rails depth Adjustable
- Static Load = 500 kg
- Variety of options available on Request (please see optional Page)
- 2 Pair of Transportation Caster Wheel
- All Keys are alike
- IP 20 Rated (NEMA 12 –IP55 available as optional on request)
- Colour BLACK RAL 9005 , or Grau 7035 , other colours available on request
- **MADE IN SAUDI ARABIA**



◆ GAMMA NET FREE STAND RACK CABINETS (600 X 600)

◆ Standard Dimensions :

Height : 18U – 21U -24U- 26U-32U

Width : 600 mm

Depth : 600 mm

◆ Standard Colour :

RAL 9005
BLACK



RAL 7035
Light Gray



Other colours available
on request



◆ Complying with International Standards:

- ISO 9001-2015
- ISO 14001:2015
- EIA/ECA- 310 E & EIA-310 D
- IEC 297-1 19" MOUNTING
- IEC 297-2 Overall cabinet dimensions
- IP20 Protected
- MADE IN KSA



GAMMA NET FREE STAND RACK CABINETS SIZE (18U – 21U –24U- 26U-32U) (600X600)

Part Number	Description - Standard Configuration - Colour Black RAL 9005 (WELDED STRUCTURE)	Width (W) mm	Depth (D) mm	Height (H) mm	Depth Rail to Rail (mm)	Static Load (KG)
GMC-FR-18U-66-2F	Gamma Net Free Stand Cabinet 18U 600×600 with Removable Side Door , Front Glass , Metal Back door , 2 pair of 19" Adjustable Pillars , 2 pair of caster Wheels , 2 Fan	600	600	895	500	400
GMC-FR-21U-66-2F	Gamma Net Free Stand Cabinet 21U 600×600 with Removable Side Door , Front Door Glass , Metal Back door , 2 pair of 19" Adjustable Mounting Pillars , 2 pair of caster Wheels , 2 Fan	600	600	985	500	400
GMC-FR-24U-66-2F	Gamma Net Free Stand Cabinet 24U 600×600 with Removable Side Door , Front Door Glass , Metal Back door , 2 pair of 19" Adjustable Pillars , 2 pair of caster Wheels , 2 Fan	600	600	1100	500	500
GMC-FR-26U-66-2F	Gamma Net Free Stand Cabinet 26U 600×600 with Removable Side Door , Front Door Glass , Metal Back door , 2 pair of 19" Adjustable Mounting Pillars , 2 pair of caster Wheels , 2 Fan	600	600	1200	500	500
GMC-FR-32U-66-2F	Gamma Net Free Stand Cabinet 32U 600×600 with Removable Side Door , Front Door Glass , Metal Back door , 2 pair of 19" Adjustable Mounting Pillars , 2 pair of caster Wheels , 2 Fan	600	600	1500	500	500

OTHER SIZES AVAILABLE ON REQUEST

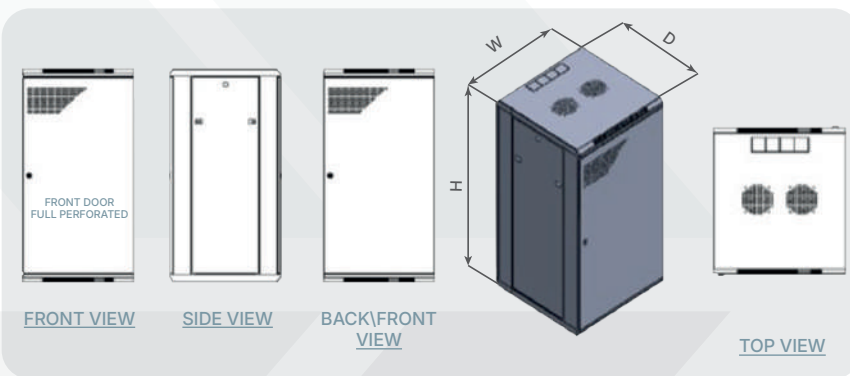

GAMMA NET FREE STAND RACK CABINETS DRAWING – 600 W
PERFORATED DOORS

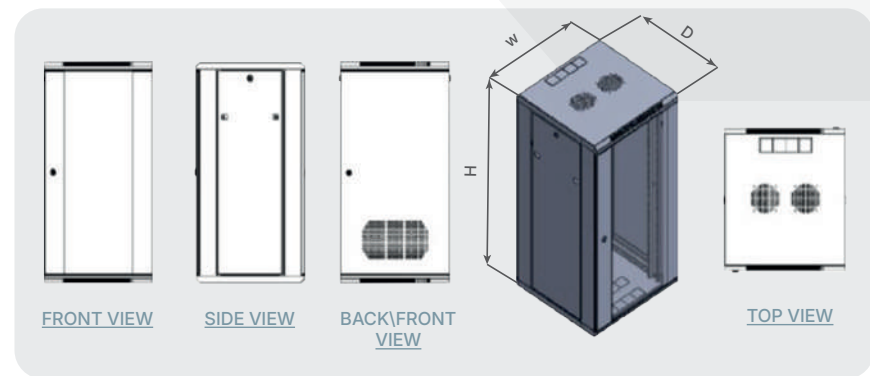

GAMMA NET FREE STAND RACK CABINETS DRAWING – 600 W
GLASS DOORS

◆ GAMMA NET FREE STAND RACK CABINETS (600 X 800)

◆ Standard Dimensions :

Height : 18U – 21U -24U- 26U-32U

Width : 600 mm

Depth : 800 mm

◆ Standard Colour :

RAL 9005
BLACK



RAL 7035
Light Gray



Other colours available
on request



◆ Complying with International Standards:

- ISO 9001-2015
- ISO 14001:2015
- EIA/ECA- 310 E & EIA-310 D
- IEC 297-1 19" MOUNTING
- IEC 297-2 Overall cabinet dimensions
- IP20 Protected
- MADE IN KSA



GAMMA NET FREE STAND RACK CABINETS SIZE (18U – 21U –24U- 26U-32U) (600X800)

Part Number	Description - Standard Configuration - Colour Black RAL 9005 (WELDED STRUCTURE)	Width (W) mm	Depth (D) mm	Height (H) mm	Depth Rail to Rail (mm)	Static Load (KG)
GMC-FR-18U-68-2F	Gamma Net Free Stand Cabinet 18U 600×800 with Removable Side Door , Front Glass , Metal Back door , 2 pair of 19" Adjustable Pillars , 2 pair of caster Wheels , 2 Fan	600	800	895	700	400
GMC-FR-21U-68-2F	Gamma Net Free Stand Cabinet 21U 600×800 with Removable Side Door , Front Door Glass , Metal Back door , 2 pair of 19" Adjustable Mounting Pillars , 2 pair of caster Wheels , 2 Fan	600	800	985	700	400
GMC-FR-24U-68-2F	Gamma Net Free Stand Cabinet 24U 600×800 with Removable Side Door , Front Door Glass , Metal Back door , 2 pair of 19" Adjustable Pillars , 2 pair of caster Wheels , 2 Fan	600	800	1100	700	500
GMC-FR-26U-68-2F	Gamma Net Free Stand Cabinet 26U 600×800 with Removable Side Door , Front Door Glass , Metal Back door , 2 pair of 19" Adjustable Mounting Pillars , 2 pair of caster Wheels , 2 Fan	600	800	1200	700	500
GMC-FR-32U-68-2F	Gamma Net Free Stand Cabinet 32U 600×800 with Removable Side Door , Front Door Glass , Metal Back door , 2 pair of 19" Adjustable Mounting Pillars , 2 pair of caster Wheels , 2 Fan	600	800	1500	700	500

OTHER SIZES AVAILABLE ON REQUEST

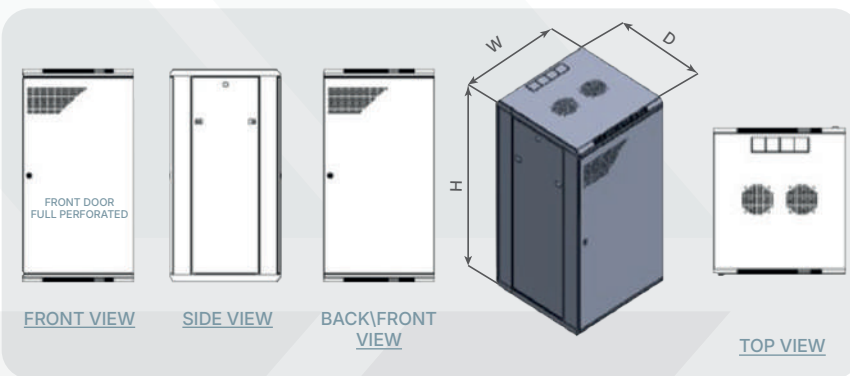

GAMMA NET FREE STAND RACK CABINETS DRAWING – 600 W
PERFORATED DOORS

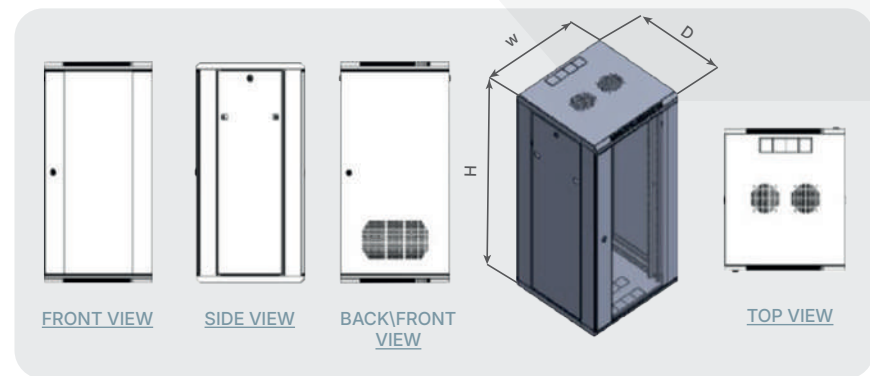

GAMMA NET FREE STAND RACK CABINETS DRAWING – 600 W
GLASS DOORS

◆ GAMMA NET FREE STAND RACK CABINETS (600 X 1000)

◆ Standard Dimensions :

Height : 18U – 21U -24U- 26U-32U

Width : 600 mm

Depth : 1000 mm

◆ Standard Colour :

RAL 9005
BLACK



RAL 7035
Light Gray



Other colours available
on request



◆ Complying with International Standards:

- ISO 9001-2015
- ISO 14001:2015
- EIA/ECA- 310 E & EIA-310 D
- IEC 297-1 19" MOUNTING
- IEC 297-2 Overall cabinet dimensions
- IP20 Protected
- MADE IN KSA



GAMMA NET FREE STAND RACK CABINETS SIZE (18U – 21U –24U- 26U-32U) (600X1000)

Part Number	Description - Standard Configuration - Colour Black RAL 9005 (WELDED STRUCTURE)	Width (W) mm	Depth (D) mm	Height (H) mm	Depth Rail to Rail (mm)	Static Load (KG)
GMC-FR-18U-610-2F	Gamma Net Free Stand Cabinet 18U 600×1000 with Removable Side Door , Front Glass , Metal Back door , 2 pair of 19" Adjustable Pillars , 2 pair of caster Wheels , 2 Fan	600	1000	895	900	400
GMC-FR-21U-610-2F	Gamma Net Free Stand Cabinet 21U 600×1000 with Removable Side Door , Front Door Glass , Metal Back door , 2 pair of 19" Adjustable Mounting Pillars , 2 pair of caster Wheels , 2 Fan	600	1000	985	900	400
GMC-FR-24U-610-2F	Gamma Net Free Stand Cabinet 24U 600×1000 with Removable Side Door , Front Door Glass , Metal Back door , 2 pair of 19" Adjustable Pillars , 2 pair of caster Wheels , 2 Fan	600	1000	1100	900	500
GMC-FR-26U-610-2F	Gamma Net Free Stand Cabinet 26U 600×1000 with Removable Side Door , Front Door Glass , Metal Back door , 2 pair of 19" Adjustable Mounting Pillars , 2 pair of caster Wheels , 2 Fan	600	1000	1200	900	500
GMC-FR-32U-610-2F	Gamma Net Free Stand Cabinet 32U 600×1000 with Removable Side Door , Front Door Glass , Metal Back door , 2 pair of 19" Adjustable Mounting Pillars , 2 pair of caster Wheels , 2 Fan	600	1000	1500	900	500

OTHER SIZES AVAILABLE ON REQUEST

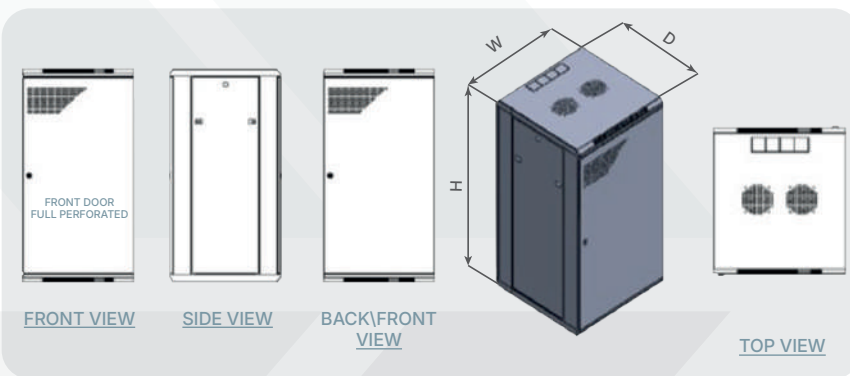

GAMMA NET FREE STAND RACK CABINETS DRAWING – 600 W
PERFORATED DOORS

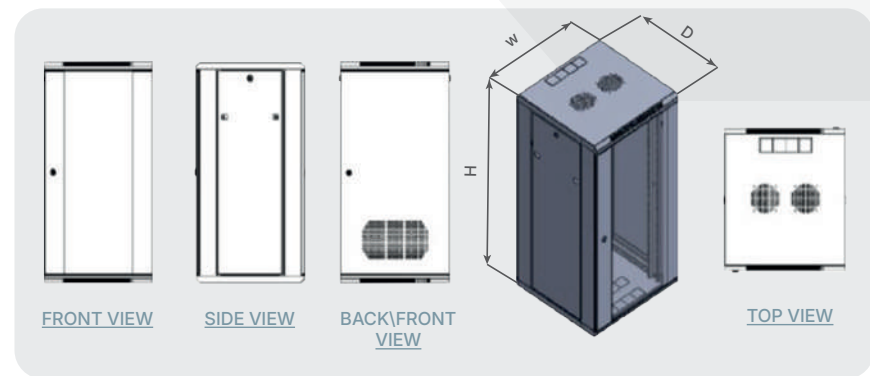

GAMMA NET FREE STAND RACK CABINETS DRAWING – 600 W
GLASS DOORS

◆ GAMMA NET FREE STAND RACK CABINETS (600 X 1200)

◆ Standard Dimensions :

Height : 18U – 21U -24U- 26U-32U

Width : 600 mm

Depth : 1200 mm

◆ Standard Colour :

RAL 9005
BLACK



RAL 7035
Light Gray



Other colours available
on request



◆ Complying with International Standards:

- ISO 9001-2015
- ISO 14001:2015
- EIA/ECA- 310 E & EIA-310 D
- IEC 297-1 19" MOUNTING
- IEC 297-2 Overall cabinet dimensions
- IP20 Protected
- MADE IN KSA



GAMMA NET FREE STAND RACK CABINETS SIZE (18U – 21U –24U- 26U-32U) (600X1200)

Part Number	Description - Standard Configuration - Colour Black RAL 9005 (WELDED STRUCTURE)	Width (W) mm	Depth (D) mm	Height (H) mm	Depth Rail to Rail (mm)	Static Load (KG)
GMC-FR-18U-612-2F	Gamma Net Free Stand Cabinet 18U 600×1200 with Removable Side Door , Front Glass , Metal Back door , 2 pair of 19" Adjustable Pillars , 2 pair of caster Wheels , 2 Fan	600	1200	895	900	400
GMC-FR-21U-612-2F	Gamma Net Free Stand Cabinet 21U 600×1200 with Removable Side Door , Front Door Glass , Metal Back door , 2 pair of 19" Adjustable Mounting Pillars , 2 pair of caster Wheels , 2 Fan	600	1200	985	900	400
GMC-FR-24U-612-2F	Gamma Net Free Stand Cabinet 24U 600×1200 with Removable Side Door , Front Door Glass , Metal Back door , 2 pair of 19" Adjustable Pillars , 2 pair of caster Wheels , 2 Fan	600	1200	1100	900	500
GMC-FR-26U-612-2F	Gamma Net Free Stand Cabinet 26U 600×1200 with Removable Side Door , Front Door Glass , Metal Back door , 2 pair of 19" Adjustable Mounting Pillars , 2 pair of caster Wheels , 2 Fan	600	1200	1200	900	500
GMC-FR-32U-612-2F	Gamma Net Free Stand Cabinet 32U 600×1200 with Removable Side Door , Front Door Glass , Metal Back door , 2 pair of 19" Adjustable Mounting Pillars , 2 pair of caster Wheels , 2 Fan	600	1200	1500	900	500

OTHER SIZES AVAILABLE ON REQUEST

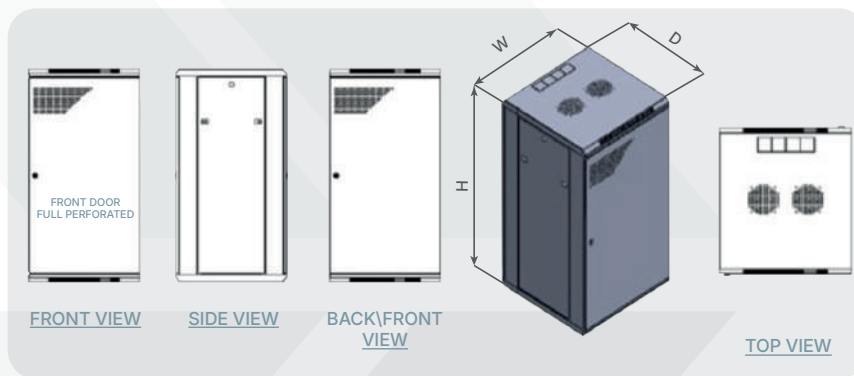

GAMMA NET FREE STAND RACK CABINETS DRAWING – 600 W
PERFORATED DOORS

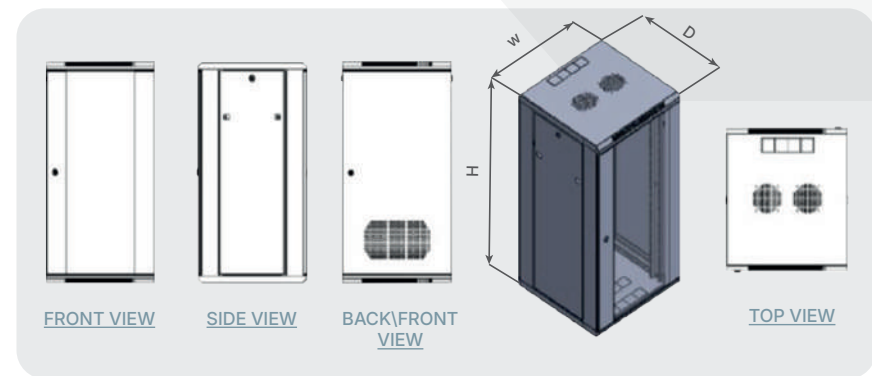

GAMMA NET FREE STAND RACK CABINETS DRAWING – 600 W
GLASS DOORS

◆ GAMMA NET FREE STAND RACK CABINETS (800 X 800)

◆ Standard Dimensions :

Height : 18U – 21U -24U- 26U-32U

Width : 800 mm

Depth : 800 mm

◆ Standard Colour :

RAL 9005
BLACK



RAL 7035
Light Gray



Other colours available
on request



◆ Complying with International Standards:

- ISO 9001-2015
- ISO 14001:2015
- EIA/ECA- 310 E & EIA-310 D
- IEC 297-1 19" MOUNTING
- IEC 297-2 Overall cabinet dimensions
- IP20 Protected
- MADE IN KSA



GAMMA NET FREE STAND RACK CABINETS SIZE (18U – 21U –24U- 26U-32U) (800X800)

Part Number	Description - Standard Configuration - Colour Black RAL 9005 (WELDED STRUCTURE)	Width (W) mm	Depth (D) mm	Height (H) mm	Depth Rail to Rail (mm)	Static Load (KG)
GMC-FR-18U-88-2F	Gamma Net Free Stand Cabinet 18U 800×800 with Removable Side Door , Front Glass , Metal Back door , 2 pair of 19" Adjustable Pillars , 2 pair of caster Wheels , 2 Fan	800	800	895	600	400
GMC-FR-21U-88-2F	Gamma Net Free Stand Cabinet 21U 800×800 with Removable Side Door , Front Door Glass , Metal Back door , 2 pair of 19" Adjustable Mounting Pillars , 2 pair of caster Wheels , 2 Fan	800	800	985	600	400
GMC-FR-24U-88-2F	Gamma Net Free Stand Cabinet 24U 800×800 with Removable Side Door , Front Door Glass , Metal Back door , 2 pair of 19" Adjustable Pillars , 2 pair of caster Wheels , 2 Fan	800	800	1100	600	500
GMC-FR-26U-88-2F	Gamma Net Free Stand Cabinet 26U 800×800 with Removable Side Door , Front Door Glass , Metal Back door , 2 pair of 19" Adjustable Mounting Pillars , 2 pair of caster Wheels , 2 Fan	800	800	1200	600	500
GMC-FR-32U-88-2F	Gamma Net Free Stand Cabinet 32U 800×800 with Removable Side Door , Front Door Glass , Metal Back door , 2 pair of 19" Adjustable Mounting Pillars , 2 pair of caster Wheels , 2 Fan	800	800	1500	600	500

OTHER SIZES AVAILABLE ON REQUEST

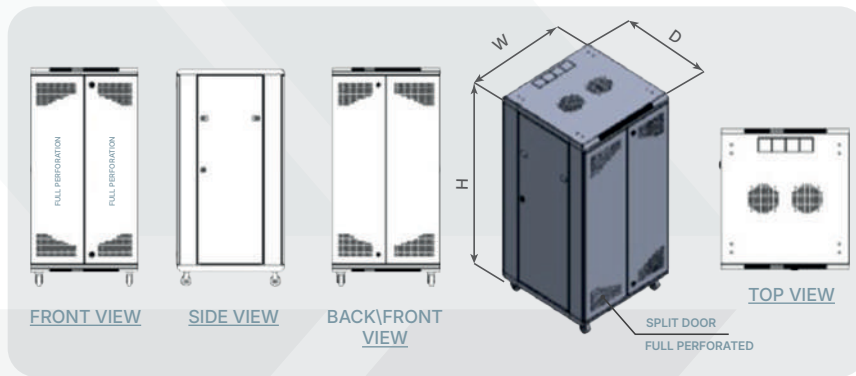

GAMMA NET FREE STAND RACK CABINETS DRAWING – 600 W
PERFORATED DOORS

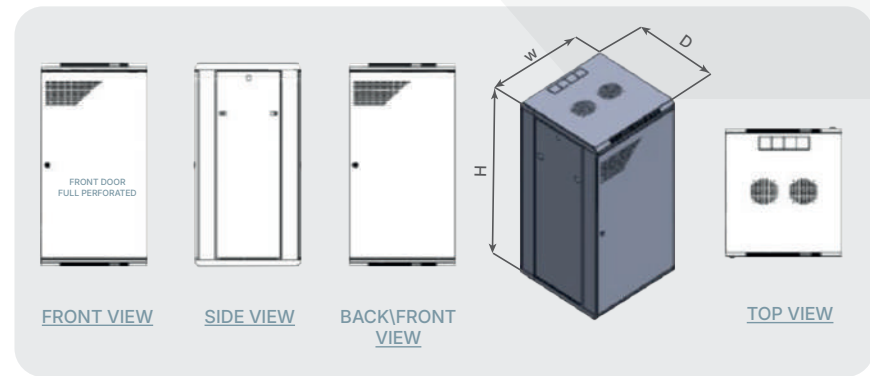

GAMMA NET FREE STAND RACK CABINETS DRAWING – 600 W
GLASS DOORS

◆ GAMMA NET FREE STAND RACK CABINETS (800 X 1000)

◆ Standard Dimensions :

Height : 18U – 21U -24U- 26U-32U

Width : 800 mm

Depth : 1000 mm

◆ Standard Colour :

RAL 9005
BLACK



RAL 7035
Light Gray



Other colours available
on request



◆ Complying with International Standards:

- ISO 9001-2015
- ISO 14001:2015
- EIA/ECA- 310 E & EIA-310 D
- IEC 297-1 19" MOUNTING
- IEC 297-2 Overall cabinet dimensions
- IP20 Protected
- MADE IN KSA



GAMMA NET FREE STAND RACK CABINETS SIZE (18U – 21U –24U- 26U-32U) (800X1000)

Part Number	Description - Standard Configuration - Colour Black RAL 9005 (WELDED STRUCTURE)	Width (W) mm	Depth (D) mm	Height (H) mm	Depth Rail to Rail (mm)	Static Load (KG)
GMC-FR-18U-810-2F	Gamma Net Free Stand Cabinet 18U 800×1000 with Removable Side Door , Front Glass , Metal Back door , 2 pair of 19" Adjustable Pillars , 2 pair of caster Wheels , 2 Fan	800	1000	895	800	400
GMC-FR-21U-810-2F	Gamma Net Free Stand Cabinet 21U 800×1000 with Removable Side Door , Front Door Glass , Metal Back door , 2 pair of 19" Adjustable Mounting Pillars , 2 pair of caster Wheels , 2 Fan	800	1000	985	800	400
GMC-FR-24U-810-2F	Gamma Net Free Stand Cabinet 24U 800×1000 with Removable Side Door , Front Door Glass , Metal Back door , 2 pair of 19" Adjustable Pillars , 2 pair of caster Wheels , 2 Fan	800	1000	1100	800	500
GMC-FR-26U-810-2F	Gamma Net Free Stand Cabinet 26U 800×1000 with Removable Side Door , Front Door Glass , Metal Back door , 2 pair of 19" Adjustable Mounting Pillars , 2 pair of caster Wheels , 2 Fan	800	1000	1200	800	500
GMC-FR-32U-810-2F	Gamma Net Free Stand Cabinet 32U 800×1000 with Removable Side Door , Front Door Glass , Metal Back door , 2 pair of 19" Adjustable Mounting Pillars , 2 pair of caster Wheels , 2 Fan	800	1000	1500	800	500

OTHER SIZES AVAILABLE ON REQUEST

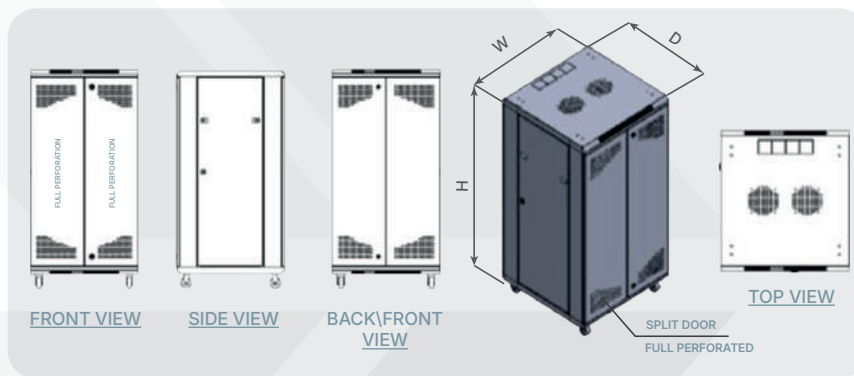

GAMMA NET FREE STAND RACK CABINETS DRAWING – 600 W
PERFORATED DOORS

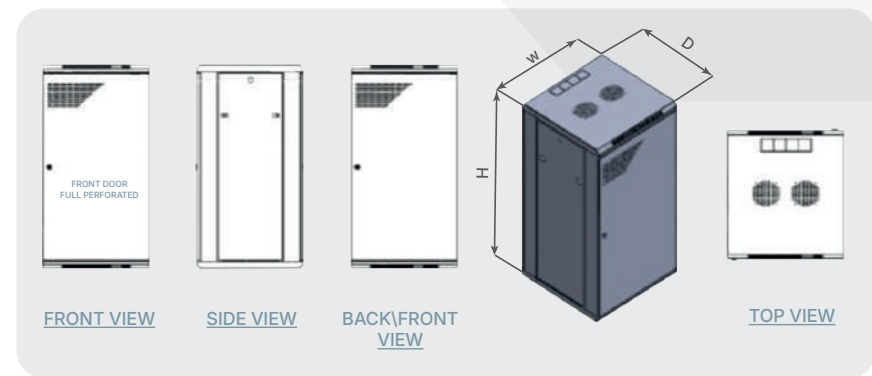

GAMMA NET FREE STAND RACK CABINETS DRAWING – 600 W
GLASS DOORS

◆ GAMMA NET FREE STAND RACK CABINETS (800 X 1200)

◆ Standard Dimensions :

Height : 18U – 21U -24U- 26U-32U

Width : 800 mm

Depth : 1200 mm

◆ Standard Colour :

RAL 9005
BLACK



RAL 7035
Light Gray



Other colours available
on request



◆ Complying with International Standards:

- ISO 9001-2015
- ISO 14001:2015
- EIA/ECA- 310 E & EIA-310 D
- IEC 297-1 19" MOUNTING
- IEC 297-2 Overall cabinet dimensions
- IP20 Protected
- MADE IN KSA



GAMMA NET FREE STAND RACK CABINETS SIZE (18U – 21U –24U- 26U-32U) (800X1200)

Part Number	Description - Standard Configuration - Colour Black RAL 9005 (WELDED STRUCTURE)	Width (W) mm	Depth (D) mm	Height (H) mm	Depth Rail to Rail (mm)	Static Load (KG)
GMC-FR-18U-812-2F	Gamma Net Free Stand Cabinet 18U 800×1200 with Removable Side Door , Front Glass , Metal Back door , 2 pair of 19" Adjustable Pillars , 2 pair of caster Wheels , 2 Fan	800	1200	895	1000	400
GMC-FR-21U-812-2F	Gamma Net Free Stand Cabinet 21U 800×1200 with Removable Side Door , Front Door Glass , Metal Back door , 2 pair of 19" Adjustable Mounting Pillars , 2 pair of caster Wheels , 2 Fan	800	1200	985	1000	400
GMC-FR-24U-812-2F	Gamma Net Free Stand Cabinet 24U 800×1200 with Removable Side Door , Front Door Glass , Metal Back door , 2 pair of 19" Adjustable Pillars , 2 pair of caster Wheels , 2 Fan	800	1200	1100	1000	500
GMC-FR-26U-812-2F	Gamma Net Free Stand Cabinet 26U 800×1200 with Removable Side Door , Front Door Glass , Metal Back door , 2 pair of 19" Adjustable Mounting Pillars , 2 pair of caster Wheels , 2 Fan	800	1200	1200	1000	500
GMC-FR-32U-812-2F	Gamma Net Free Stand Cabinet 32U 800×1200 with Removable Side Door , Front Door Glass , Metal Back door , 2 pair of 19" Adjustable Mounting Pillars , 2 pair of caster Wheels , 2 Fan	800	1200	1500	1000	500

OTHER SIZES AVAILABLE ON REQUEST

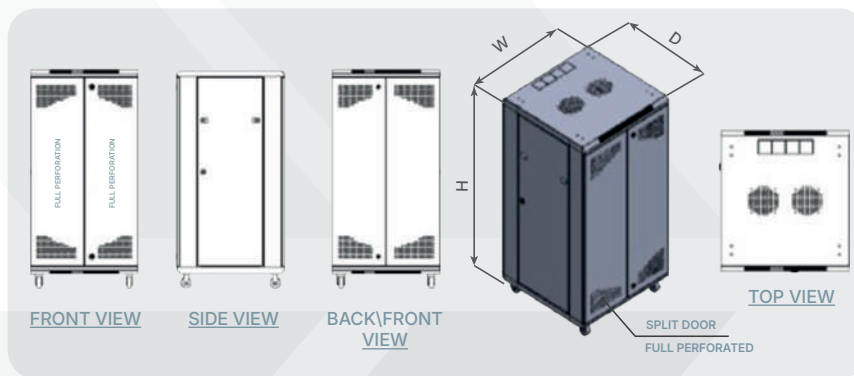

GAMMA NET FREE STAND RACK CABINETS DRAWING – 600 W
PERFORATED DOORS

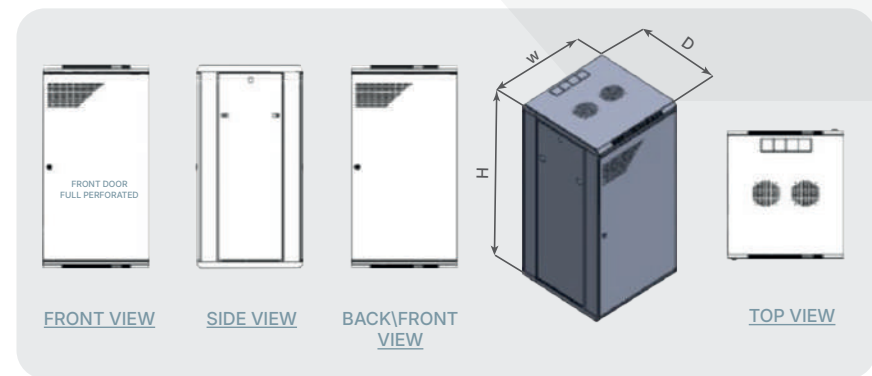

GAMMA NET FREE STAND RACK CABINETS DRAWING – 600 W
GLASS DOORS

◆ GAMMA NET FREE STAND RACK CABINETS (36U-42U-45U-47U) 600 X 600

◆ Standard Dimensions :

U-Height : 36U-42U-45U-47U

Width : 600 mm

Depth : 600 mm

◆ Standard Colour :

RAL 9005
BLACK



RAL 7035
Light Gray



Other colours available
on request



◆ Complying with International Standards:

- ISO 9001-2015
- ISO 14001:2015
- EIA/ECA- 310 E & EIA-310 D
- IEC 297-1 19" MOUNTING
- IEC 297-2 Overall cabinet dimensions
- IP20 Protected
- MADE IN KSA



◆ GAMMA NET FREE STAND CABINETS SECTION

› Features:

- GAMMA Data Cabinets 600 X 600
- Made from Steel Welded Frame .
- Front Glass Door with swing Handle Lock and side perforation
- Double door front and back full perforated with Handle lock (optional)
- Back door with Key lock and Ventilation
- Removable Side Doors,1 Key lock and 2 Plastic Latched each side
- Cable Inlet from Top & Bottom
- Vertical Cable Management with Cover (2 pcs at front side)
- 4 Fans, 100 CFM/Fan , 220 Volts
- 2 Pair of 19" Mounting Rails depth Adjustable
- 1 Pair of Metal Vertical Cable Management with Cover at front side
- Static Load = 800 kg
- Variety of options available on Request (please see optional Page)
- 2 Pair of Transportation Caster Wheel
- All Keys are alike
- IP 20 Rated (NEMA 12 –IP55 available as optional on request)
- Color BLACK RAL 9005 , or Grau 7035 , other colors available on request
- **MADE IN SAUDI ARABIA**



GAMMA NET FREE STAND RACK CABINETS SIZE 36 U – 47U (600X600)

Part Number	Description - Standard Configuration - Colour Black RAL 9005 (WELDED STRUCTURE)	Width (W) mm	Depth (D) mm	Height (H) mm	Depth Rail to Rail (mm)	Static Load (KG)
GMC-FR-36U-66-4F	Gamma Net Free Stand Cabinet 36U 600×600 with Removable Side Door, Front Glass , Metal Back door ,2 pair of 19" Adjustable Pillars , 2 pair of caster Wheels , 4 Fan	600	600	1720	500	600
GMC-FR-42U-66-4F	Gamma Net Free Stand Cabinet 42U 600×600 with Removable Side Door , Front Glass , Metal Back door , 2 pair of 19" Adjustable Pillars , 2 pair of caster Wheels , 4 Fan	600	600	2020	500	800
GMC-FR-45U-66-4F	Gamma Net Free Stand Cabinet 45U 600×600 with Removable Side Door , Front Glass , Metal Back door , 2 pair of 19" Adjustable Pillars , 2 pair of caster Wheels , 4 Fan	600	600	2160	500	800
GMC-FR-47U-66-4F	Gamma Net Free Stand Cabinet 47U 600×600 with Removable Side Door , Front Glass , Metal Back door , 4 pair of 19" Adjustable Pillars , 2 pair of caster Wheels , 4 Fan	600	600	2250	700	800

OTHER SIZES AVAILABLE ON REQUEST

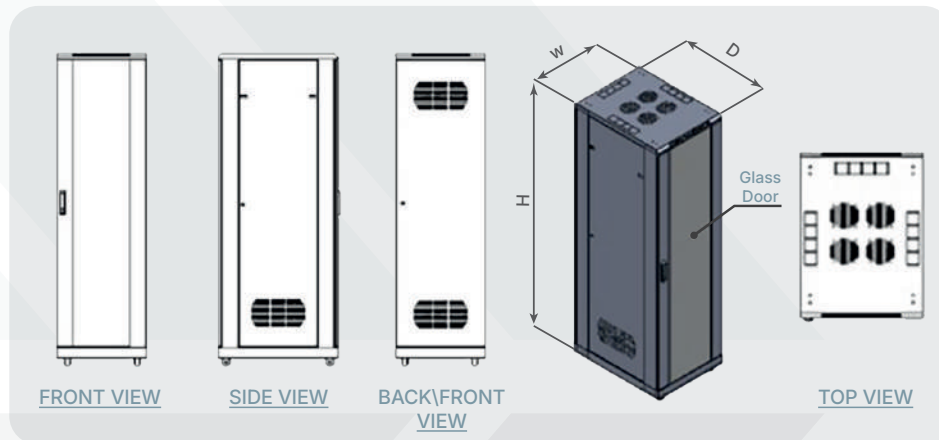

GAMMA NET FREE STAND RACK CABINETS DRAWING – 600 W
GLASS DOORS

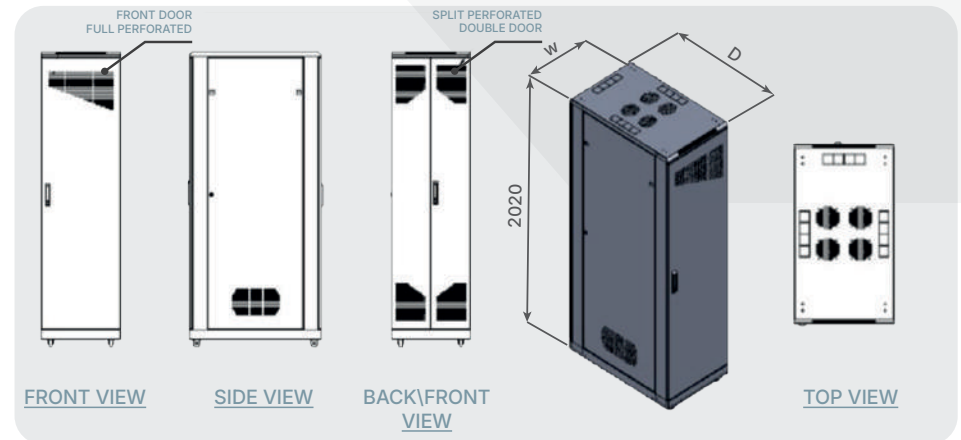

GAMMA NET FREE STAND RACK CABINETS DRAWING – 600 W
PERFORATED DOORS

GAMMA NET FREE STAND RACK CABINETS (36U-42U-45U-47U) 600 X 800

◆ Standard Dimensions :

U-Height : 36U-42U-45-47U

Width : 600 mm

Depth : 800 mm

◆ Standard Colour :

RAL 9005
BLACK



RAL 7035
Light Gray



Other colours available
on request



◆ Complying with International Standards:

- ISO 9001-2015
- ISO 14001:2015
- EIA/ECA- 310 E & EIA-310 D
- IEC 297-1 19" MOUNTING
- IEC 297-2 Overall cabinet dimensions
- IP20 Protected
- MADE IN KSA



◆ GAMMA NET FREE STAND CABINETS SECTION

› Features:

- GAMMA NET Data Cabinets 600 X 800
- Made from Steel Welded Frame .
- Front Glass Door with swing Handle Lock and side perforation
- Double door front and back full perforated with Handle lock (optional)
- Back door with Key lock and Ventilation
- Removable Side Doors,1 Key lock and 2 Plastic Latched each side
- Cable Inlet from Top & Bottom
- Vertical Cable Management with Cover (2 pcs at front side)
- 4 Fans, 100 CFM/Fan , 220 Volts
- 2 Pair of 19" Mounting Rails depth Adjustable
- 1 Pair of Metal Vertical Cable Management with Cover at front side
- Static Load = 800 kg
- Variety of options available on Request (please see optional Page)
- 2 Pair of Transportation Caster Wheel
- All Keys are alike
- IP 20 Rated (NEMA 12 –IP55 available as optional on request)
- Color BLACK RAL 9005 , or Grau 7035 , other colors available on request
- **MADE IN SAUDI ARABIA**



GAMMA NET FREE STAND RACK CABINETS SIZE 36U – 47U (600X800)

Part Number	Description - Standard Configuration - Colour Black RAL 9005 (WELDED STRUCTURE)	Width (W) mm	Depth (D) mm	Height (H) mm	Depth Rail to Rail (mm)	Static Load (KG)
GMC-FR-36U-68-4F	Gamma Net Free Stand Cabinet 36U 600×800 with Removable Side Door , Front Glass , Metal Back door , 2 pair of 19" Adjustable Pillars , 2 pair of caster Wheels , 4 Fan	600	800	1720	700	600
GMC-FR-42U-68-4F	Gamma Net Free Stand Cabinet 42U 600×800 with Removable Side Door , Front Glass , Metal Back door , 2 pair of 19" Adjustable Pillars , 2 pair of caster Wheels , 4 Fan	600	800	2020	700	800
GMC-FR-45U-68-4F	Gamma Net Free Stand Cabinet 45U 600×800 with Removable Side Door , Front Glass , Metal Back door , 2 pair of 19" Adjustable Pillars , 2 pair of caster Wheels , 4 Fan	600	800	2160	700	800
GMC-FR-47U-68-4F	Gamma Net Free Stand Cabinet 47U 600×800 with Removable Side Door , Front Glass , Metal Back door , 4 pair of 19" Adjustable Pillars , 2 pair of caster Wheels , 4 Fan	600	800	2250	700	800

OTHER SIZES AVAILABLE ON REQUEST

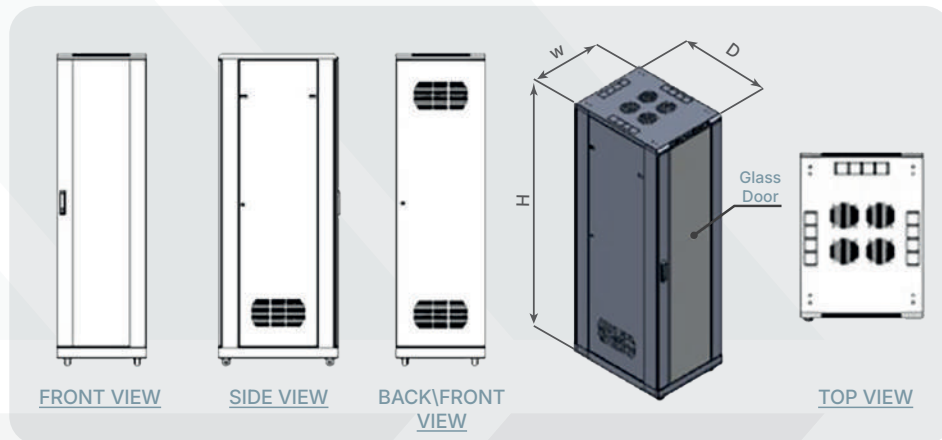

GAMMA NET FREE STAND RACK CABINETS DRAWING – 600 W
GLASS DOORS

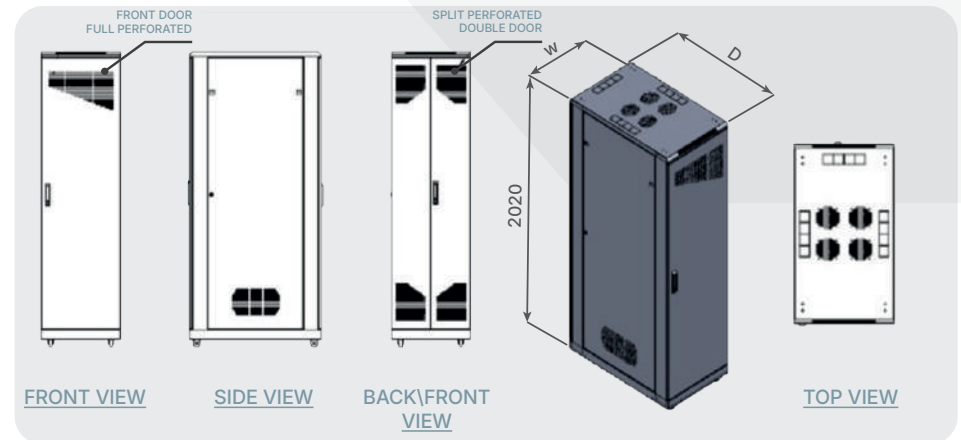

GAMMA NET FREE STAND RACK CABINETS DRAWING – 600 W
PERFORATED DOORS

GAMMA NET FREE STAND RACK CABINETS (36U-42U-45U-47U) 600 X 1000

◆ Standard Dimensions :

U-Height : 36U-42U-45U-47U

Width : 600 mm

Depth : 1000 mm

◆ Standard Colour :

RAL 9005
BLACK



RAL 7035
Light Gray



Other colours available
on request



◆ Complying with International Standards:

- ISO 9001-2015
- ISO 14001:2015
- EIA/ECA- 310 E & EIA-310 D
- IEC 297-1 19" MOUNTING
- IEC 297-2 Overall cabinet dimensions
- IP20 Protected
- MADE IN KSA



◆ GAMMA NET FREE STAND CABINETS SECTION

› Features:

- GAMMA NET Data Cabinets 600 X 1000
- Made from Steel Welded Frame.
- Front Glass Door with swing Handle Lock and side perforation
- Double door front and back full perforated with Handle lock (optional)
- Back door with Key lock and Ventilation
- Removable Side Doors,1 Key lock and 2 Plastic Latched each side
- Cable Inlet from Top & Bottom
- Vertical Cable Management with Cover (2 pcs at front side)
- 4 Fans, 100 CFM/Fan , 220 Volts
- 2 Pair of 19" Mounting Rails depth Adjustable
- 1 Pair of Metal Vertical Cable Management with Cover at front side
- Static Load = 800 kg
- Variety of options available on Request (please see optional Page)
- 2 Pair of Transportation Caster Wheel
- All Keys are alike
- IP 20 Rated (NEMA 12 –IP55 available as optional on request)
- Color BLACK RAL 9005 , or Grau 7035 , other colors available on request
- **MADE IN SAUDI ARABIA**



GAMMA NET FREE STAND RACK CABINETS SIZE 36U – 47U (600X1000)

Part Number	Description - Standard Configuration - Colour Black RAL 9005 (WELDED STRUCTURE)	Width (W) mm	Depth (D) mm	Height (H) mm	Depth Rail to Rail (mm)	Static Load (KG)
GMC-FR-36U-610-4F	Gamma Net Free Stand Cabinet 36U 600×1000 with Removable Side Door , Front Glass , Metal Back door , 2 pair of 19" Adjustable Pillars , 2 pair of caster Wheels , 4 Fan	600	1000	1720	900	600
GMC-FR-42U-610-4F	Gamma Net Free Stand Cabinet 42U 600×1000 with Removable Side Door , Front Glass , Metal Back door , 2 pair of 19" Adjustable Pillars , 2 pair of caster Wheels , 4 Fan	600	1000	2020	900	800
GMC-FR-45U-610-4F	Gamma Net Free Stand Cabinet 45U 600×1000 with Removable Side Door , Front Glass , Metal Back door , 2 pair of 19" Adjustable Pillars , 2 pair of caster Wheels , 4 Fan	600	1000	2160	900	800
GMC-FR-47U-610-4F	Gamma Net Free Stand Cabinet 47U 600×1000 with Removable Side Door , Front Glass , Metal Back door , 4 pair of 19" Adjustable Pillars , 2 pair of caster Wheels , 4 Fan	600	1000	2250	900	800

OTHER SIZES AVAILABLE ON REQUEST

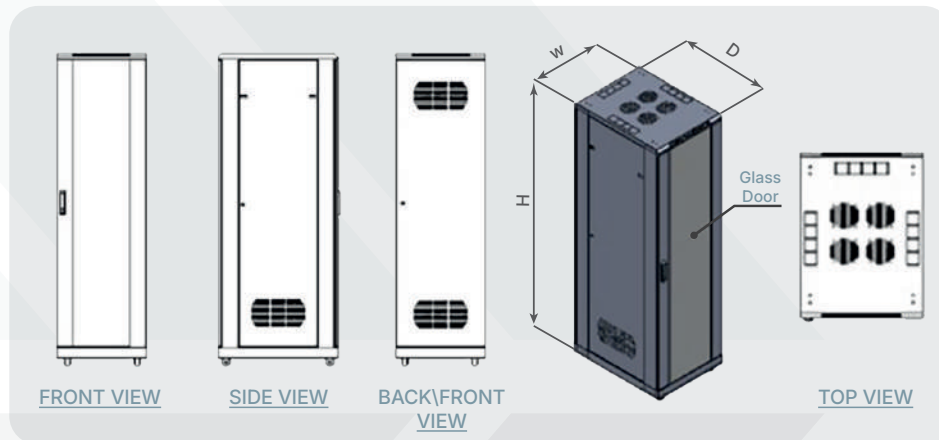

GAMMA NET FREE STAND RACK CABINETS DRAWING – 600 W
GLASS DOORS

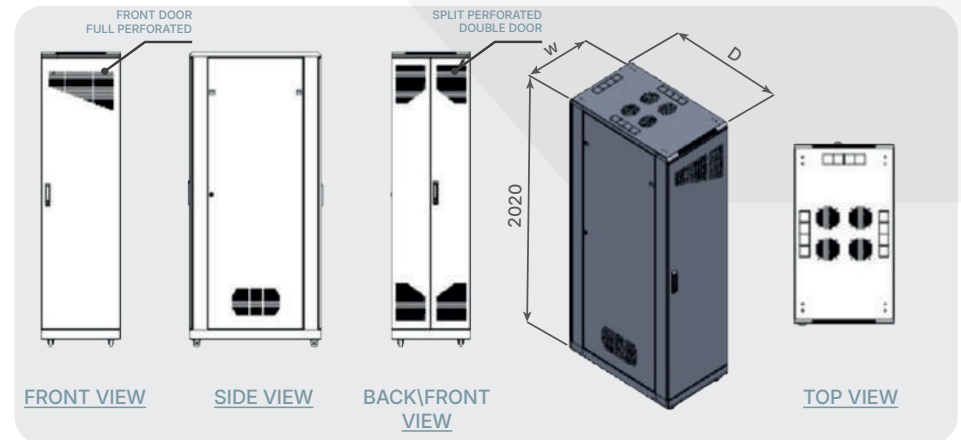

GAMMA NET FREE STAND RACK CABINETS DRAWING – 600 W
PERFORATED DOORS

GAMMA NET FREE STAND RACK CABINETS (36U-42U-45U-47U) 600 X 1200

◆ Standard Dimensions :

U-Height : 36U-42U-45U-47U

Width : 600 mm

Depth : 1200 mm

◆ Standard Colour :

RAL 9005
BLACK



RAL 7035
Light Gray



Other colours available
on request



◆ Complying with International Standards:

- ISO 9001-2015
- ISO 14001:2015
- EIA/ECA- 310 E & EIA-310 D
- IEC 297-1 19" MOUNTING
- IEC 297-2 Overall cabinet dimensions
- IP20 Protected
- MADE IN KSA

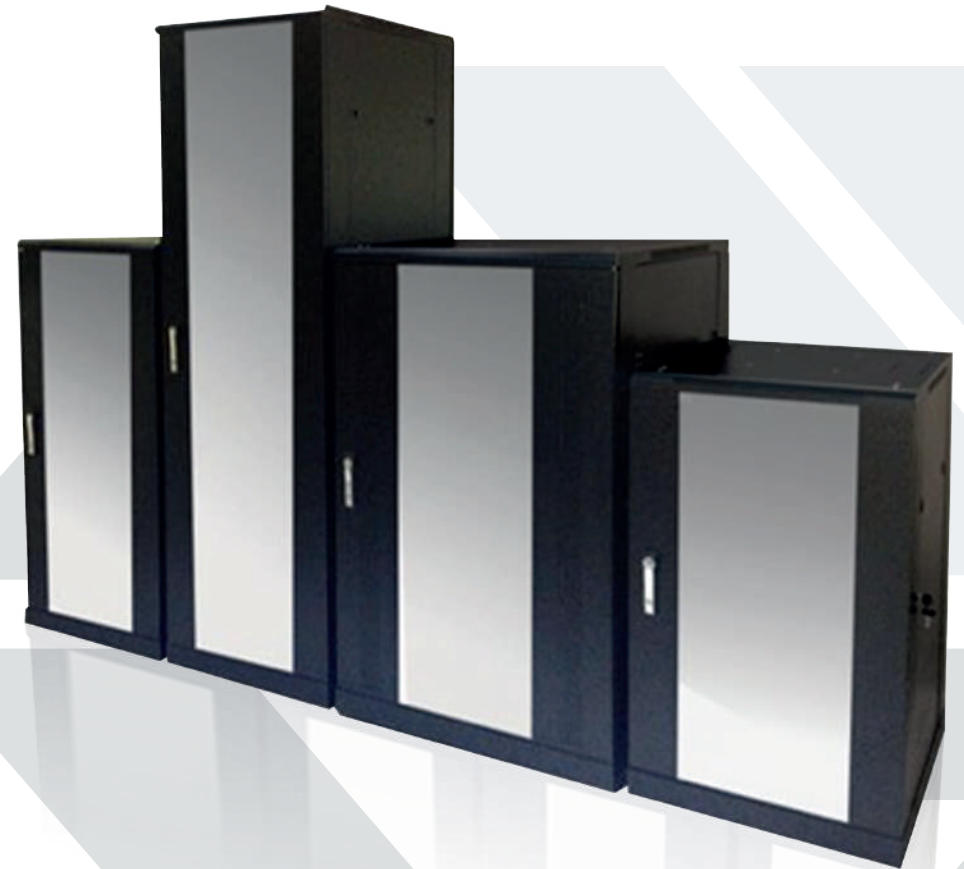

◆ GAMMA NET FREE STAND CABINETS SECTION

› Features:

- GAMMA NET Data Cabinets 600 X 1200
- Made from Steel Welded Frame.
- Front Glass Door with swing Handle Lock and side perforation
- Double door front and back full perforated with Handle lock (optional)
- Back door with Key lock and Ventilation
- Removable Side Doors,1 Key lock and 2 Plastic Latched each side
- Cable Inlet from Top & Bottom
- Vertical Cable Management with Cover (2 pcs at front side)
- 4 Fans, 100 CFM/Fan , 220 Volts
- 2 Pair of 19" Mounting Rails depth Adjustable
- 1 Pair of Metal Vertical Cable Management with Cover at front side
- Static Load = 800 kg
- Variety of options available on Request (please see optional Page)
- 2 Pair of Transportation Caster Wheel
- All Keys are alike
- IP 20 Rated (NEMA 12 –IP55 available as optional on request)
- Color BLACK RAL 9005 , or Grau 7035 , other colors available on request
- **MADE IN SAUDI ARABIA**



GAMMA NET FREE STAND RACK CABINETS SIZE 36U – 47U (600X1200)

Part Number	Description - Standard Configuration - Colour Black RAL 9005 (WELDED STRUCTURE)	Width (W) mm	Depth (D) mm	Height (H) mm	Depth Rail to Rail (mm)	Static Load (KG)
GMC-FR-36U-612-4F	Gamma Net Free Stand Cabinet 36U 600×1200 with Removable Side Door , Front Glass , Metal Back door , 2 pair of 19" Adjustable Pillars , 2 pair of caster Wheels , 4 Fan	600	1200	1720	1100	600
GMC-FR-42U-612-4F	Gamma Net Free Stand Cabinet 42U 600×1200 with Removable Side Door , Front Glass , Metal Back door , 2 pair of 19" Adjustable Pillars , 2 pair of caster Wheels , 4 Fan	600	1200	2020	1100	800
GMC-FR-45U-612-4F	Gamma Net Free Stand Cabinet 45U 600×1200 with Removable Side Door , Front Glass , Metal Back door , 2 pair of 19" Adjustable Pillars , 2 pair of caster Wheels , 4 Fan	600	1200	2160	1100	800
GMC-FR-47U-612-4F	Gamma Net Free Stand Cabinet 47U 600×1200 with Removable Side Door , Front Glass , Metal Back door , 4 pair of 19" Adjustable Pillars , 2 pair of caster Wheels , 4 Fan	600	1200	2250	1100	800

OTHER SIZES AVAILABLE ON REQUEST

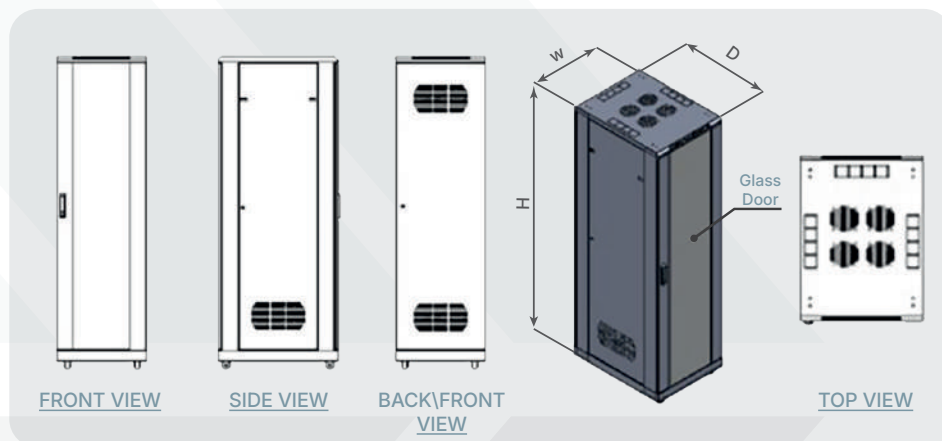

GAMMA NET FREE STAND RACK CABINETS DRAWING – 600 W
GLASS DOORS

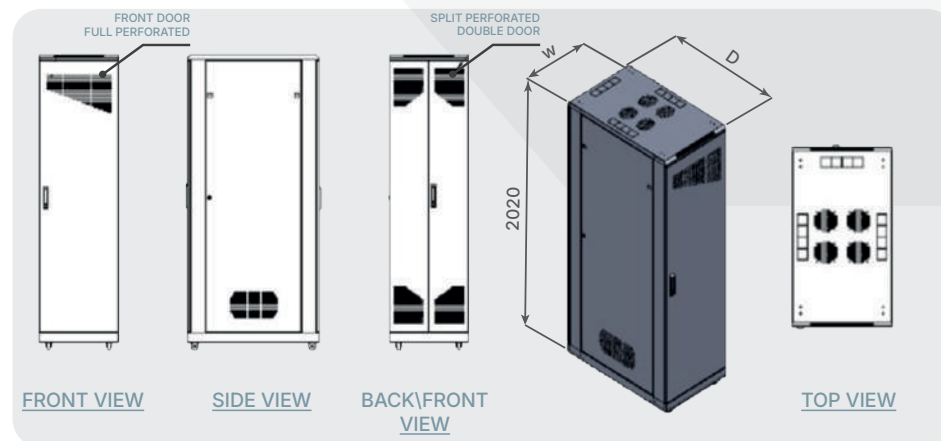

GAMMA NET FREE STAND RACK CABINETS DRAWING – 600 W
PERFORATED DOORS

GAMMA NET FREE STAND RACK CABINETS (36U-42U-45U-47U) 800 X 800

◆ Standard Dimensions :

U-Height : 36U-42U-45U-47U

Width : 800 mm

Depth : 800 mm

◆ Standard Colour :

RAL 9005
BLACK



RAL 7035
Light Gray



Other colours available
on request



◆ Complying with International Standards:

- ISO 9001-2015
- ISO 14001:2015
- EIA/ECA- 310 E & EIA-310 D
- IEC 297-1 19" MOUNTING
- IEC 297-2 Overall cabinet dimensions
- IP20 Protected
- MADE IN KSA



◆ GAMMA NET FREE STAND CABINETS SECTION

› Features:

- GAMMA Data Cabinets 800 X 800
- Made from Steel Welded Frame.
- Front Glass Door with swing Handle Lock and side perforation
- Double door front and back full perforated with Handle lock (optional)
- Back door with Key lock and Ventilation
- Removable Side Doors,1 Key lock and 2 Plastic Latched each side
- Cable Inlet from Top & Bottom
- Vertical Cable Management with Cover (2 pcs at front side)
- 4 Fans, 100 CFM/Fan , 220 Volts
- 2 Pair of 19" Mounting Rails depth Adjustable
- 1 Pair of Metal Vertical Cable Management with Cover at front side
- Static Load = 800 kg
- Variety of options available on Request (please see optional Page)
- 2 Pair of Transportation Caster Wheel
- All Keys are alike
- IP 20 Rated (NEMA 12 –IP55 available as optional on request)
- Color BLACK RAL 9005 , or Grau 7035 , other colors available on request
- **MADE IN SAUDI ARABIA**



GAMMA NET FREE STAND RACK CABINETS SIZE 36U – 47U (800X800)

Part Number	Description - Standard Configuration - Colour Black RAL 9005 (WELDED STRUCTURE)	Width (W) mm	Depth (D) mm	Height (H) mm	Depth Rail to Rail (mm)	Static Load (KG)
GMC-FR-36U-88-4F	Gamma Net Free Stand Cabinet 36U 800×800 with Removable Side Door , Front Glass , Metal Back door , 2 pair of 19" Adjustable Pillars , 2 pair of caster Wheels , 4 Fan	800	800	1720	600	600
GMC-FR-42U-88-4F	Gamma Net Free Stand Cabinet 42U 800×800 with Removable Side Door , Front Glass , Metal Back door , 2 pair of 19" Adjustable Pillars , 2 pair of caster Wheels , 4 Fan	800	800	2020	600	800
GMC-FR-45U-88-4F	Gamma Net Free Stand Cabinet 45U 800×800 with Removable Side Door , Front Glass , Metal Back door , 2 pair of 19" Adjustable Pillars , 2 pair of caster Wheels , 4 Fan	800	800	2160	600	800
GMC-FR-47U-88-4F	Gamma Net Free Stand Cabinet 47U 800×800 with Removable Side Door , Front Glass , Metal Back door , 4 pair of 19" Adjustable Pillars , 2 pair of caster Wheels , 4 Fan	800	800	2250	600	800

OTHER SIZES AVAILABLE ON REQUEST

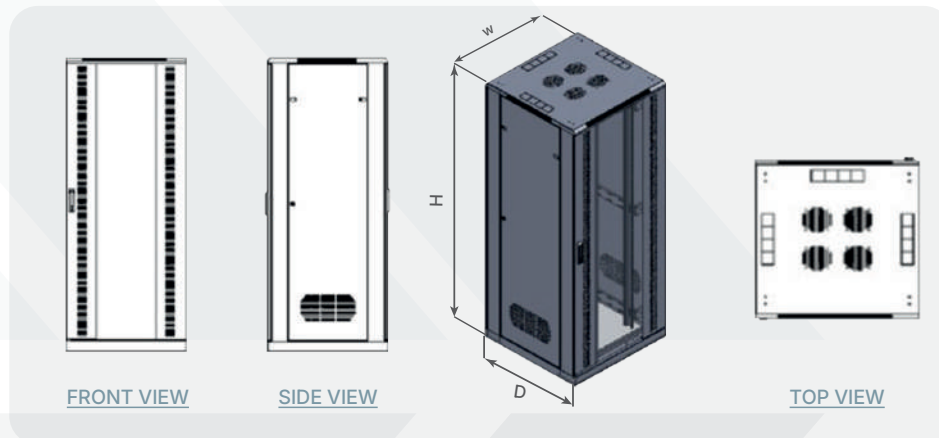

GAMMA NET FREE STAND RACK CABINETS DRAWING – 600 W
GLASS DOORS

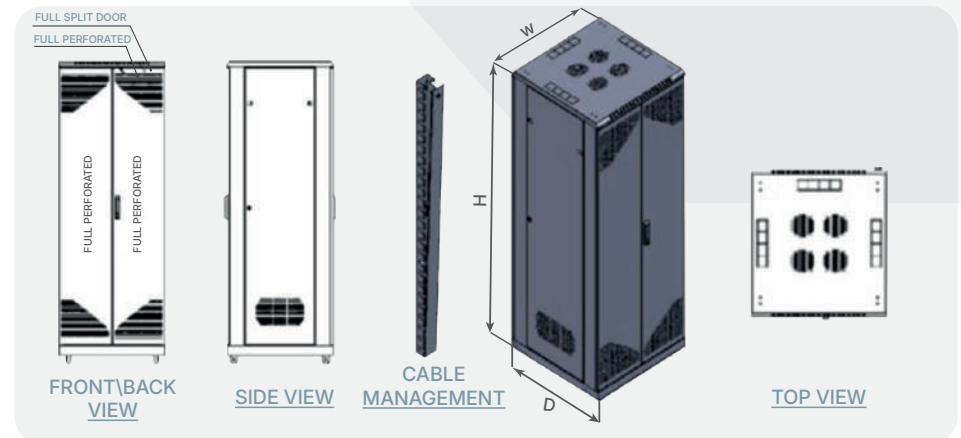

GAMMA NET FREE STAND RACK CABINETS DRAWING – 600 W
PERFORATED DOORS

GAMMA NET FREE STAND RACK CABINETS (36U-42U-45U-47U) 800 X 1000

◆ Standard Dimensions :

U-Height : 36U-42U-45U-47U

Width : 800 mm

Depth : 1000 mm

◆ Standard Colour :

RAL 9005
BLACK



RAL 7035
Light Gray



Other colours available
on request



◆ Complying with International Standards:

- ISO 9001-2015
- ISO 14001:2015
- EIA/ECA- 310 E & EIA-310 D
- IEC 297-1 19" MOUNTING
- IEC 297-2 Overall cabinet dimensions
- IP20 Protected
- MADE IN KSA



◆ GAMMA NET FREE STAND CABINETS SECTION

› Features:

- GAMMA Data Cabinets 800 X 1000
- Made from Steel Welded Frame
- Front Glass Door with swing Handle Lock and side perforation
- Double door front and back full perforated with Handle lock (optional)
- Back door with Key lock and Ventilation
- Removable Side Doors,1 Key lock and 2 Plastic Latched each side
- Cable Inlet from Top & Bottom
- Vertical Cable Management with Cover (2 pcs at front side)
- 4 Fans, 100 CFM/Fan , 220 Volts
- 2 Pair of 19" Mounting Rails depth Adjustable
- 1 Pair of Metal Vertical Cable Management with Cover at front side
- Static Load = 800 kg
- Variety of options available on Request (please see optional Page)
- 2 Pair of Transportation Caster Wheel
- All Keys are alike
- IP 20 Rated (NEMA 12 -IP55 available as optional on request)
- Color BLACK RAL 9005 , or Grau 7035 , other colors available on request
- **MADE IN SAUDI ARABIA**



GAMMA NET FREE STAND RACK CABINETS SIZE 36U – 47U (800X1000)

Part Number	Description - Standard Configuration - Colour Black RAL 9005 (WELDED STRUCTURE)	Width (W) mm	Depth (D) mm	Height (H) mm	Depth Rail to Rail (mm)	Static Load (KG)
GMC-FR-36U-810-4F	Gamma Net Free Stand Cabinet 36U 800×1000 with Removable Side Door , Front Glass , Metal Back door , 2 pair of 19" Adjustable Pillars , 2 pair of caster Wheels , 4 Fan	800	1000	1720	800	600
GMC-FR-42U-810-4F	Gamma Net Free Stand Cabinet 42U 800×1000 with Removable Side Door , Front Glass , Metal Back door , 2 pair of 19" Adjustable Pillars , 2 pair of caster Wheels , 4 Fan	800	1000	2020	800	800
GMC-FR-45U-810-4F	Gamma Net Free Stand Cabinet 45U 800×1000 with Removable Side Door , Front Glass , Metal Back door , 2 pair of 19" Adjustable Pillars , 2 pair of caster Wheels , 4 Fan	800	1000	2160	800	800
GMC-FR-47U-810-4F	Gamma Net Free Stand Cabinet 47U 800×1000 with Removable Side Door , Front Glass , Metal Back door , 4 pair of 19" Adjustable Pillars , 2 pair of caster Wheels , 4 Fan	800	1000	2250	800	800

OTHER SIZES AVAILABLE ON REQUEST

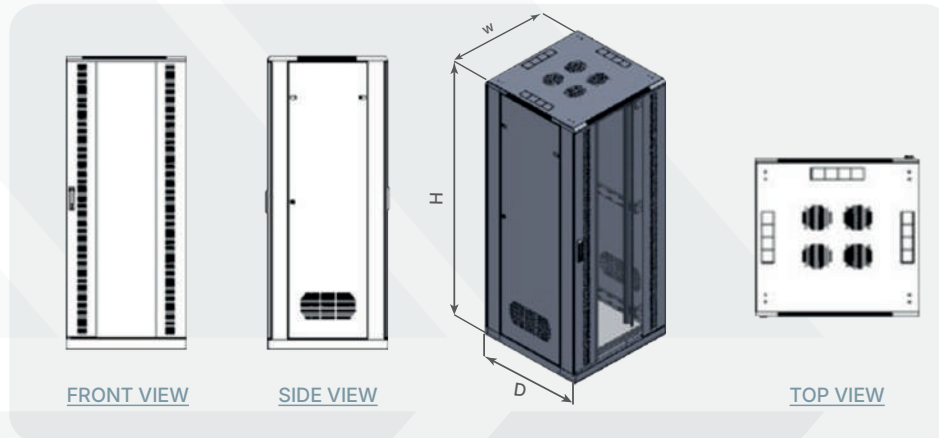

GAMMA NET FREE STAND RACK CABINETS DRAWING – 600 W
GLASS DOORS

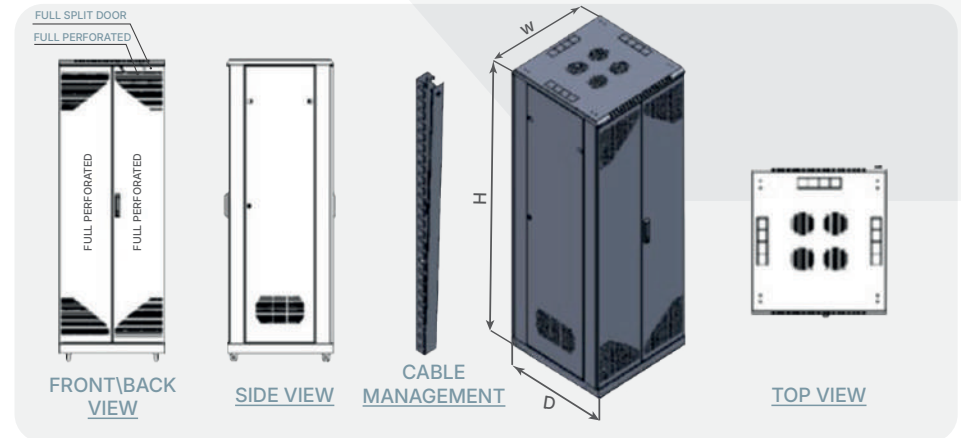

GAMMA NET FREE STAND RACK CABINETS DRAWING – 600 W
PERFORATED DOORS

◆ GAMMA NET FREE STAND RACK CABINETS (36U-42U-45U-47U) 800 X 1200

◆ Standard Dimensions :

U-Height : 36U-42U-45U-47U

Width : 800 mm

Depth : 1200 mm

◆ Standard Colour :

RAL 9005
BLACK



RAL 7035
Light Gray



Other colours available
on request



◆ Complying with International Standards:

- ISO 9001-2015
- ISO 14001:2015
- EIA/ECA- 310 E & EIA-310 D
- IEC 297-1 19" MOUNTING
- IEC 297-2 Overall cabinet dimensions
- IP20 Protected
- MADE IN KSA



◆ GAMMA NET FREE STAND CABINETS SECTION

› Features:

- GAMMA Data Cabinets 800 X 1200
- Made from Steel Welded Frame
- Front Glass Door with swing Handle Lock and side perforation
- Double door front and back full perforated with Handle lock (optional)
- Back door with Key lock and Ventilation
- Removable Side Doors,1 Key lock and 2 Plastic Latched each side
- Cable Inlet from Top & Bottom
- Vertical Cable Management with Cover (2 pcs at front side)
- 4 Fans, 100 CFM/Fan , 220 Volts
- 2 Pair of 19" Mounting Rails depth Adjustable
- 1 Pair of Metal Vertical Cable Management with Cover at front side
- Static Load = 800 kg
- Variety of options available on Request (please see optional Page)
- 2 Pair of Transportation Caster Wheel
- All Keys are alike
- IP 20 Rated (NEMA 12 -IP55 available as optional on request)
- Color BLACK RAL 9005 , or Grau 7035 , other colors available on request
- **MADE IN SAUDI ARABIA**



GAMMA NET FREE STAND RACK CABINETS SIZE 36U – 47U (800X1200)

Part Number	Description - Standard Configuration - Colour Black RAL 9005 (WELDED STRUCTURE)	Width (W) mm	Depth (D) mm	Height (H) mm	Depth Rail to Rail (mm)	Static Load (KG)
GMC-FR-36U-812-4F	Gamma Net Free Stand Cabinet 36U 800×1200 with Removable Side Door , Front Glass , Metal Back door , 2 pair of 19" Adjustable Pillars , 2 pair of caster Wheels , 4 Fan	800	1200	1720	1000	600
GMC-FR-42U-812-4F	Gamma Net Free Stand Cabinet 42U 800×1200 with Removable Side Door , Front Glass , Metal Back door , 2 pair of 19" Adjustable Pillars , 2 pair of caster Wheels , 4 Fan	800	1200	2020	1000	800
GMC-FR-45U-812-4F	Gamma Net Free Stand Cabinet 45U 800×1200 with Removable Side Door , Front Glass , Metal Back door , 2 pair of 19" Adjustable Pillars , 2 pair of caster Wheels , 4 Fan	800	1200	2160	1000	800
GMC-FR-47U-812-4F	Gamma Net Free Stand Cabinet 47U 800×1200 with Removable Side Door , Front Glass , Metal Back door , 4 pair of 19" Adjustable Pillars , 2 pair of caster Wheels , 4 Fan	800	1200	2250	1000	800

OTHER SIZES AVAILABLE ON REQUEST

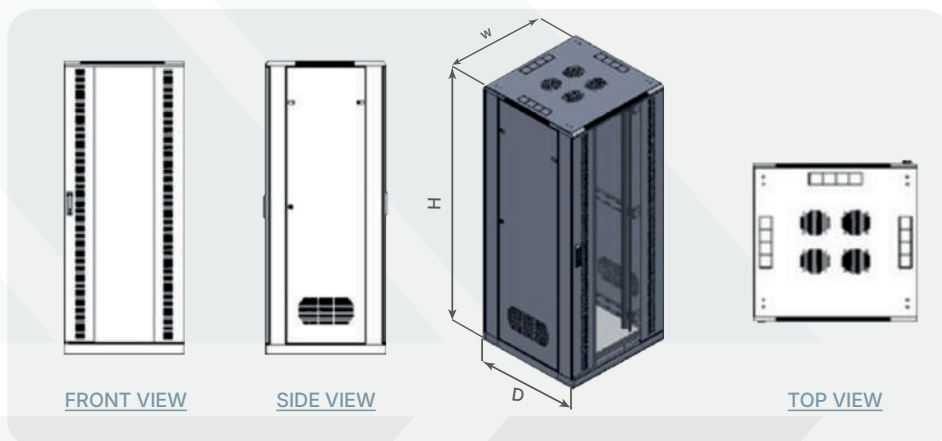

GAMMA NET FREE STAND RACK CABINETS DRAWING – 600 W
GLASS DOORS

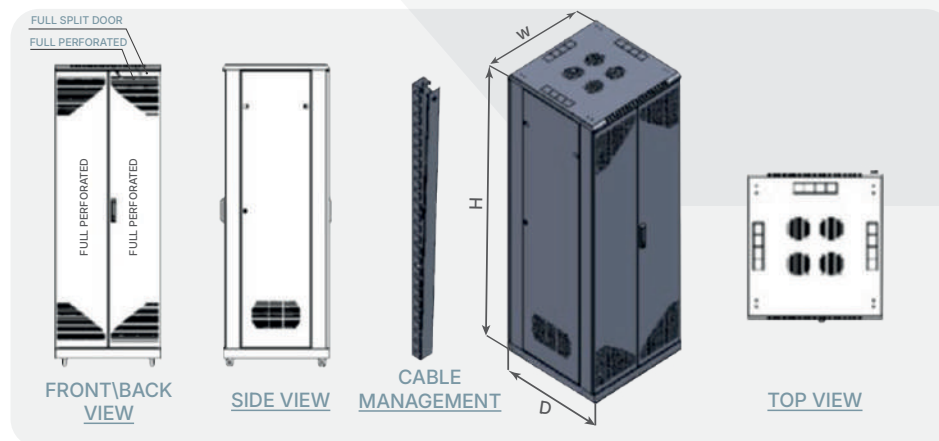

GAMMA NET FREE STAND RACK CABINETS DRAWING – 600 W
PERFORATED DOORS

GAMMA DC FLEX DATA CENTER CABINETS

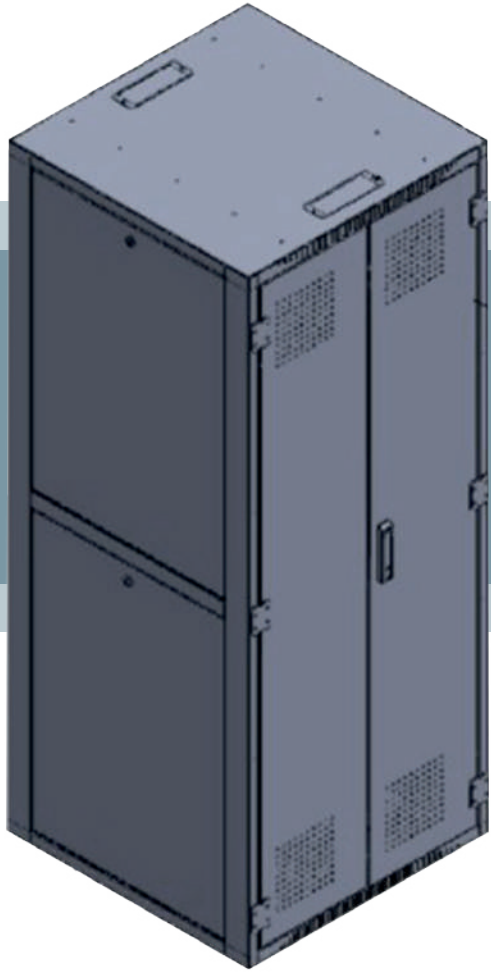

◆ GAMMA DC FLEX DATA CENTER CABINETS (42U-45U-47U) 600 X 1000

◆ Standard Dimensions :

U-Height : 42U-45-47U

Width : 600 mm

Depth : 1000 mm

◆ Standard Colour :

RAL 9005
BLACK



RAL 7035
Light Gray



Other colours available
on request



◆ Complying with International Standards:

- ISO 9001-2015
- ISO 14001:2015
- EIA/ECA- 310 E & EIA-310 D
- IEC 297-1 19" MOUNTING
- IEC 297-2 Overall cabinet dimensions
- IP20 Protected
- MADE IN KSA

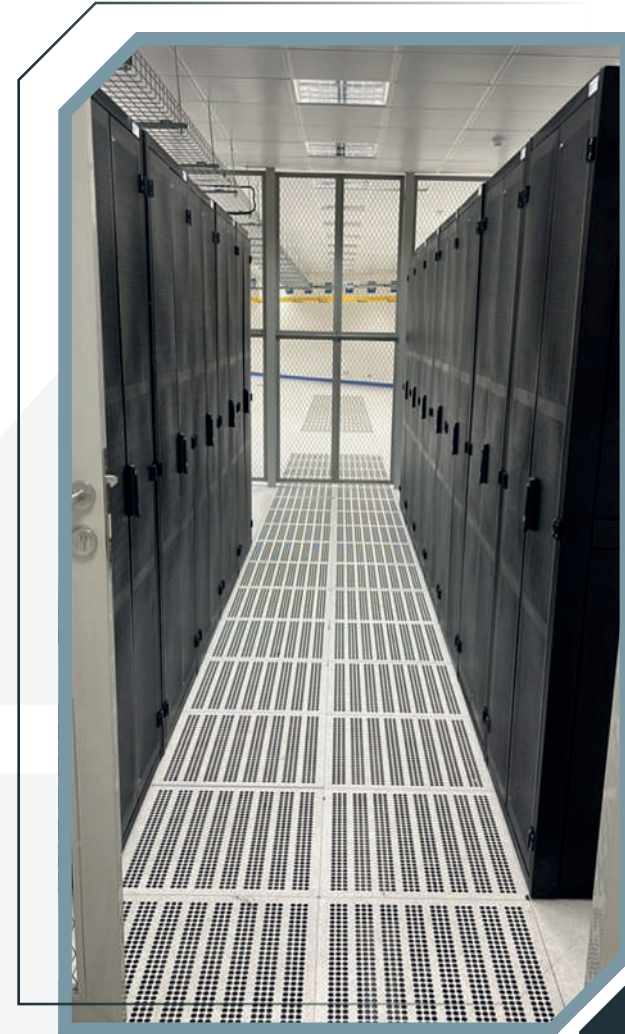

GAMMA DC FLEX DATA CENTER CABINETS SECTION

> Features:

- GAMMA DC Flex Data Center Cabinets Height : 42U /45U /47U
- Size (W X D) : 600 X 1000
- Made from Heavy Duty Steel Welded structure .
- Double door front and back full perforated
- Handle lock 3-point lock – (Optional Security lock with access card)
- Solid Split Side Doors,1 Key lock , with solid hinges
- Solid Top with Cable Inlet from Top front /back and side
- 2 Pair of 19" Mounting Rails depth Adjustable
- Static Load = 1100 kg
- 2 Pair of Transportation Caster Wheel and HD levelling feet
- Variety of options available on Request (please see optional Page)
- (Optional) Vertical Cable Management with Cover (2 pcs at front side)
- (Optional) 4 Fans, 105 CFM/Fan , 220 Volts
- (Optional) Brush for Cable Inlet
- (Optional) Security Access lock with card and key lock
- IP 20 Rated
- All Keys are alike
- Colour BLACK RAL 9005 , or Gray 7035 , other colours available on request
- Part # GMC-DC-FLEX-XXU-610 (XX = U Height)
- **MADE IN SAUDI ARABIA**

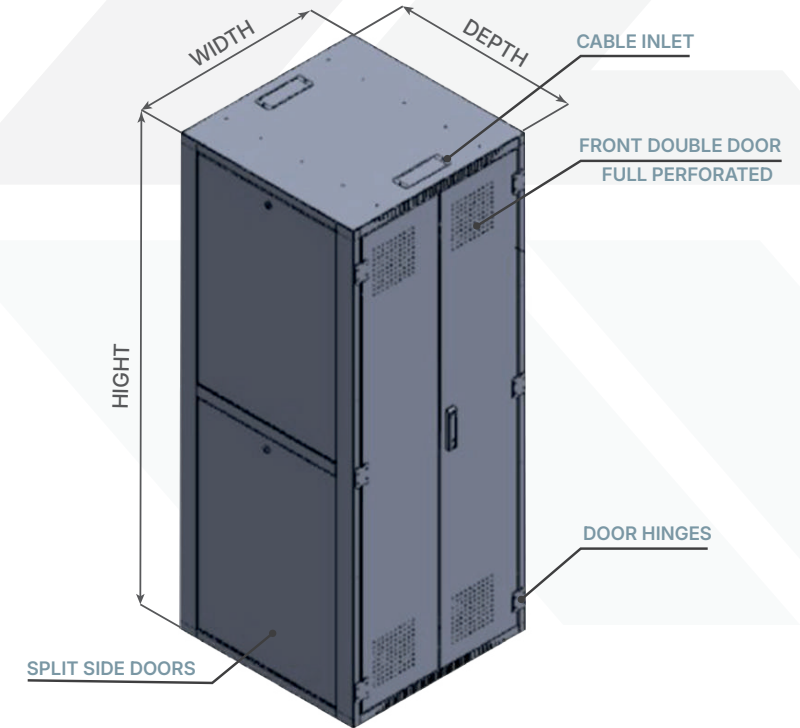

GAMMA DC FLEX DATA CENTER CABINETS (42U-45U-47U) 600 X 1000

Part Number	Description - Standard Configuration - Colour Black RAL 9005 (WELDED STRUCTURE)	Width (W) mm	Depth (D) mm	Height (H) mm	Depth Rail to Rail (mm)	Static Load (KG)
GMC-DC-FLEX-42U-610	Gamma DC Flex Data Center Cabinets 42U 600×1000 with Removable Solid Split Side Doors, Double door front and back full perforated , 2 pair of 19" Adjustable Pillars , 2 pair of caster Wheels	600	1000	2020	900	1100
GMC-DC-FLEX-45U-610	Gamma DC Flex Data Center Cabinets 45U 600×1000 with Removable Solid Split Side Doors, Double door front and back full perforated , 2 pair of 19" Adjustable Pillars , 2 pair of caster Wheels	600	1000	2160	900	1100
GMC-DC-FLEX-47U-610	Gamma DC Flex Data Center Cabinets 47U 600×1000 with Removable Solid Split Side Doors, Double door front and back full perforated , 2 pair of 19" Adjustable Pillars , 2 pair of caster Wheels	600	1000	2250	900	1100

OTHER SIZES AVAILABLE ON REQUEST

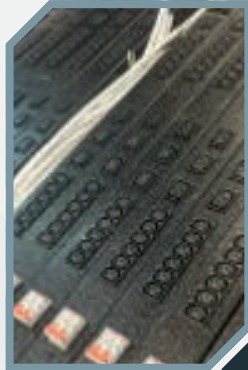

GAMMA VERTICAL PDU Models :

1. Basic PDU with Braker
2. Meter PDU with braker For Voltage and Amps and Watt
20 X C13 + 4 X C19 , 16 or 32 Amps (4 / 8 / 16 KW -220-250 V)
Power cord 1.8 m (3m option) Industrial Plug

ELECTRONIC LOCK WITH IC CARD (OPTIONAL)

Operation Instructions

1. After the controller powers on the electronic lock control wire, use the IC card to swipe the card in the designated swiping area. After the IC card matches the electronic lock, the green light flashes, and then press the circle position under the handle to turn on the electronic lock (if you don't press, The green light keeps flashing and waits for n seconds before the system automatically shuts down).
2. Rotate the handle to drive the steel bolt, connecting rod and other locking mechanisms to complete the opening action.
3. For key opening, first use the tool key to open the dust cover, then insert the key, and turn it clockwise to open the handle

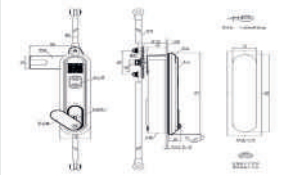

GAMMA DC FLEX DATA CENTER CABINETS (42U-45U-47U) 600 X 1200

◆ Standard Dimensions :

U-Height : 42U-45-47U

Width : 600 mm

Depth : 1200 mm

◆ Standard Colour :

RAL 9005
BLACK



RAL 7035
Light Gray



Other colours available
on request



◆ Complying with International Standards:

- ISO 9001-2015
- ISO 14001:2015
- EIA/ECA- 310 E & EIA-310 D
- IEC 297-1 19" MOUNTING
- IEC 297-2 Overall cabinet dimensions
- IP20 Protected
- MADE IN KSA

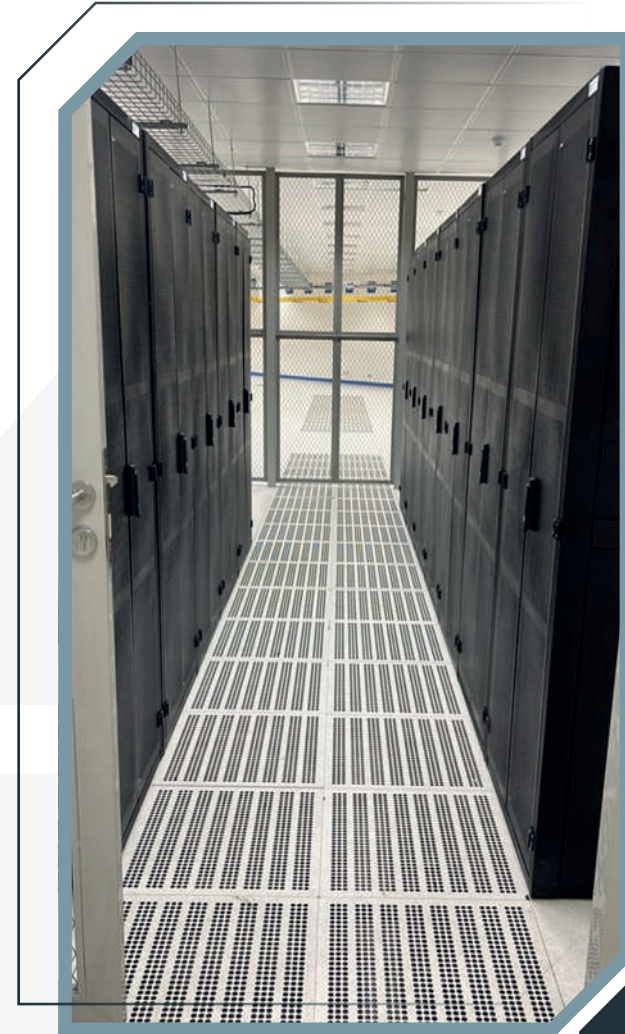

GAMMA DC FLEX DATA CENTER CABINETS SECTION

> Features:

- GAMMA DC Flex Data Center Cabinets Height : 42U /45U /47U
- Size (W X D) : 600 X 1200
- Made from Heavy Duty Steel Welded structure .
- Double door front and back full perforated
- Handle lock 3-point lock – (Optional Security lock with access card)
- Solid Split Side Doors,1 Key lock , with solid hinges
- Solid Top with Cable Inlet from Top front /back and side
- 2 Pair of 19" Mounting Rails depth Adjustable
- Static Load = 1100 kg
- 2 Pair of Transportation Caster Wheel and HD levelling feet
- Variety of options available on Request (please see optional Page)
- (Optional) Vertical Cable Management with Cover (2 pcs at front side)
- (Optional) 4 Fans, 105 CFM/Fan , 220 Volts
- (Optional) Brush for Cable Inlet
- (Optional) Security Access lock with card and key lock
- IP 20 Rated
- All Keys are alike
- Colour BLACK RAL 9005 , or Gray 7035 , other colours available on request
- Part # GMC-DC-FLEX-XXU-610 (XX = U Height)
- **MADE IN SAUDI ARABIA**

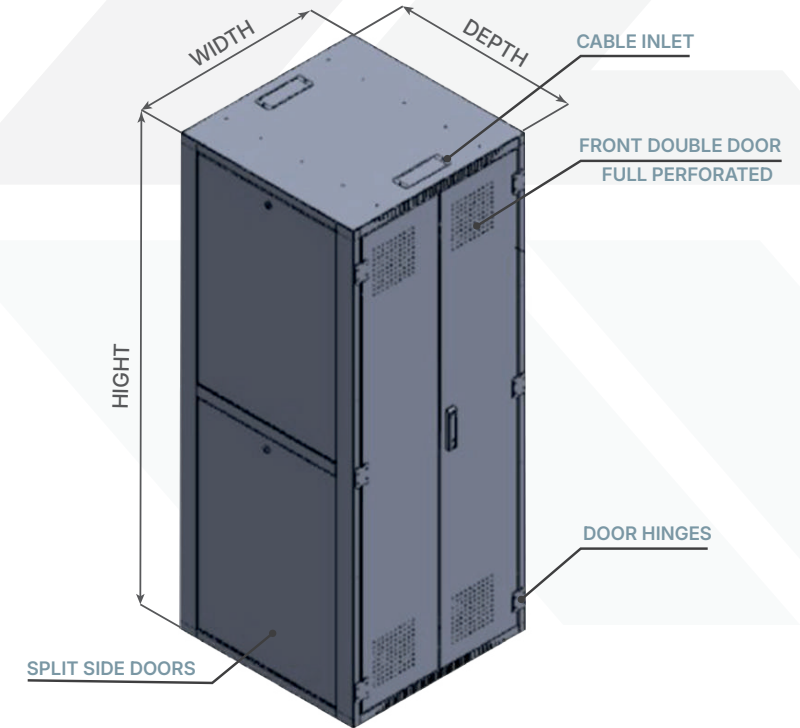

GAMMA DC FLEX DATA CENTER CABINETS (42U-45U-47U) 600 X 1000

Part Number	Description - Standard Configuration - Colour Black RAL 9005 (WELDED STRUCTURE)	Width (W) mm	Depth (D) mm	Height (H) mm	Depth Rail to Rail (mm)	Static Load (KG)
GMC-DC-FLEX-42U-612	Gamma DC Flex Data Center Cabinets 42U 600×1200 with Removable Solid Split Side Doors, Double door front and back full perforated , 2 pair of 19" Adjustable Pillars , 2 pair of caster Wheels	600	1200	2020	1100	1100
GMC-DC-FLEX-45U-612	Gamma DC Flex Data Center Cabinets 45U 600×1200 with Removable Solid Split Side Doors, Double door front and back full perforated , 2 pair of 19" Adjustable Pillars , 2 pair of caster Wheels	600	1200	2160	1100	1100
GMC-DC-FLEX-47U-612	Gamma DC Flex Data Center Cabinets 47U 600×1200 with Removable Solid Split Side Doors, Double door front and back full perforated , 2 pair of 19" Adjustable Pillars , 2 pair of caster Wheels	600	1200	2250	1100	1100

OTHER SIZES AVAILABLE ON REQUEST

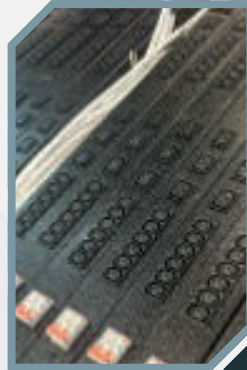

GAMMA VERTICAL PDU Models :

1. Basic PDU with Braker
2. Meter PDU with braker For Voltage and Amps and Watt
20 X C13 + 4 X C19 , 16 or 32 Amps (4 / 8 / 16 KW -220-250 V)
Power cord 1.8 m (3m option) Industrial Plug

ELECTRONIC LOCK WITH IC CARD (OPTIONAL)

Operation Instructions

1. After the controller powers on the electronic lock control wire, use the IC card to swipe the card in the designated swiping area. After the IC card matches the electronic lock, the green light flashes, and then press the circle position under the handle to turn on the electronic lock (if you don't press, The green light keeps flashing and waits for n seconds before the system automatically shuts down).
2. Rotate the handle to drive the steel bolt, connecting rod and other locking mechanisms to complete the opening action.
3. For key opening, first use the tool key to open the dust cover, then insert the key, and turn it clockwise to open the handle

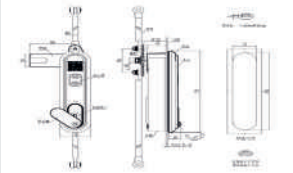

GAMMA DC FLEX DATA CENTER CABINETS (42U-45U-47U) 800 X 800

◆ Standard Dimensions :

U-Height : 42U-45-47U

Width : 800 mm

Depth : 800 mm

◆ Standard Colour :

RAL 9005
BLACK



RAL 7035
Light Gray



Other colours available
on request



◆ Complying with International Standards:

- ISO 9001-2015
- ISO 14001:2015
- EIA/ECA- 310 E & EIA-310 D
- IEC 297-1 19" MOUNTING
- IEC 297-2 Overall cabinet dimensions
- IP20 Protected
- MADE IN KSA

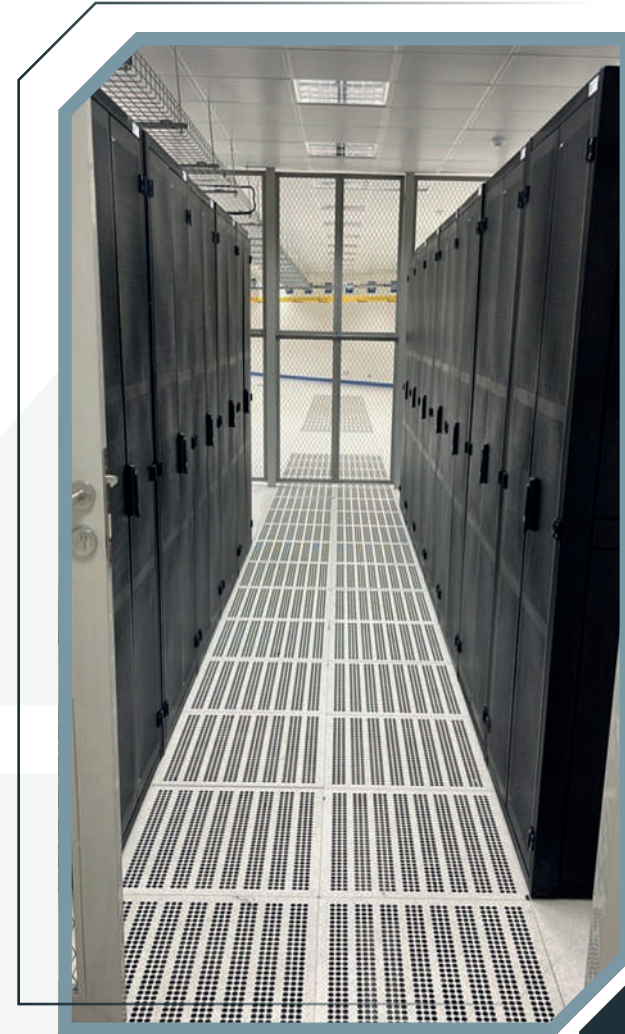

◇ GAMMA DC FLEX DATA CENTER CABINETS SECTION

› Features:

- GAMMA DC Flex Data Center Cabinets Height : 42U /45U /47U
- Size (W X D) : 800 X 800
- Made from Heavy Duty Steel Welded structure .
- Double door front and back full perforated
- Handle lock 3-point lock – (Optional Security lock with access card)
- Solid Split Side Doors,1 Key lock , with solid hinges
- Solid Top with Cable Inlet from Top front /back and side
- 2 Pair of 19" Mounting Rails depth Adjustable
- Static Load = 1100 kg
- 2 Pair of Transportation Caster Wheel and HD levelling feet
- Variety of options available on Request (please see optional Page)
- (Optional) Vertical Cable Management with Cover (2 pcs at front side)
- (Optional) 4 Fans, 105 CFM/Fan , 220 Volts
- (Optional) Brush for Cable Inlet
- (Optional) Security Access lock with card and key lock
- IP 20 Rated
- All Keys are alike
- Colour BLACK RAL 9005 , or Gray 7035 , other colours available on request
- Part # GMC-DC-FLEX-XXU-610 (XX = U Height)
- **MADE IN SAUDI ARABIA**

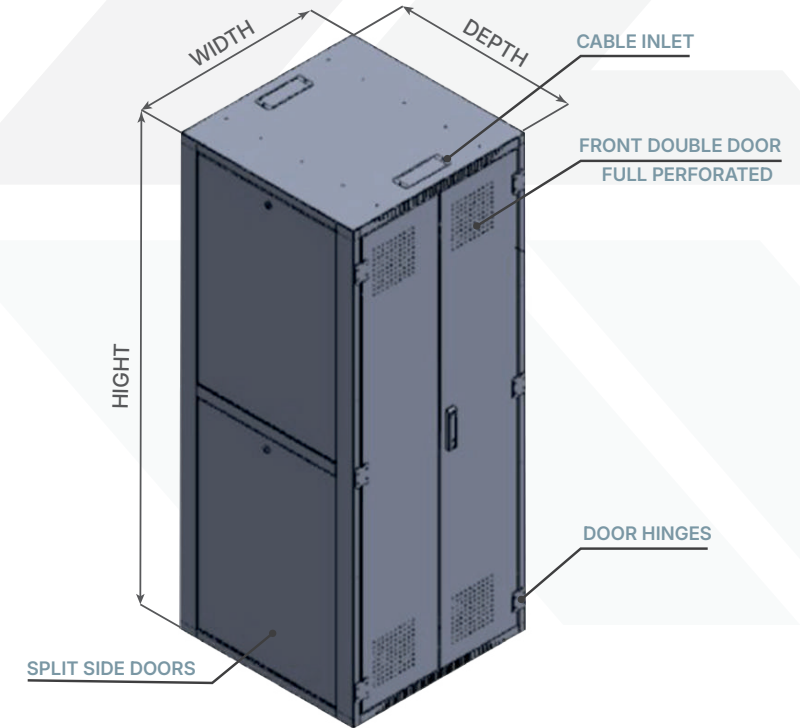

GAMMA DC FLEX DATA CENTER CABINETS (42U-45U-47U) 800 X 800

Part Number	Description - Standard Configuration - Colour Black RAL 9005 (WELDED STRUCTURE)	Width (W) mm	Depth (D) mm	Height (H) mm	Depth Rail to Rail (mm)	
GMC-DC-FLEX-42U-88	Gamma DC Flex Data Center Cabinets 42U 800×800 with Removable Solid Split Side Doors, Double door front and back full perforated , 2 pair of 19" Adjustable Pillars , 2 pair of caster Wheels	800	800	2020	650	1100
GMC-DC-FLEX-45U-88	Gamma DC Flex Data Center Cabinets 45U 800×800 with Removable Solid Split Side Doors, Double door front and back full perforated , 2 pair of 19" Adjustable Pillars , 2 pair of caster Wheels	800	800	2160	650	1100
GMC-DC-FLEX-47U-88	Gamma DC Flex Data Center Cabinets 47U 800×800 with Removable Solid Split Side Doors, Double door front and back full perforated , 2 pair of 19" Adjustable Pillars , 2 pair of caster Wheels	800	800	2250	650	1100

OTHER SIZES AVAILABLE ON REQUEST

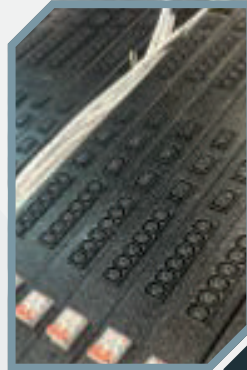

GAMMA VERTICAL PDU Models :

1. Basic PDU with Braker
2. Meter PDU with braker For Voltage and Amps and Watt
20 X C13 + 4 X C19 , 16 or 32 Amps (4 / 8 / 16 KW -220-250 V)
Power cord 1.8 m (3m option) Industrial Plug

ELECTRONIC LOCK WITH IC CARD (OPTIONAL)

Operation Instructions

1. After the controller powers on the electronic lock control wire, use the IC card to swipe the card in the designated swiping area. After the IC card matches the electronic lock, the green light flashes, and then press the circle position under the handle to turn on the electronic lock (if you don't press, The green light keeps flashing and waits for n seconds before the system automatically shuts down).
2. Rotate the handle to drive the steel bolt, connecting rod and other locking mechanisms to complete the opening action.
3. For key opening, first use the tool key to open the dust cover, then insert the key, and turn it clockwise to open the handle

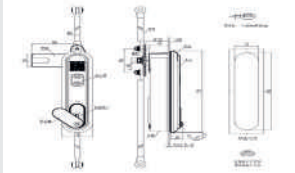

GAMMA DC FLEX DATA CENTER CABINETS (42U-45U-47U) 800 X 1000

◆ Standard Dimensions :

U-Height : 42U-45-47U

Width : 800 mm

Depth : 1000 mm

◆ Standard Colour :

RAL 9005
BLACK



RAL 7035
Light Gray



Other colours available
on request



◆ Complying with International Standards:

- ISO 9001-2015
- ISO 14001:2015
- EIA/ECA- 310 E & EIA-310 D
- IEC 297-1 19" MOUNTING
- IEC 297-2 Overall cabinet dimensions
- IP20 Protected
- MADE IN KSA

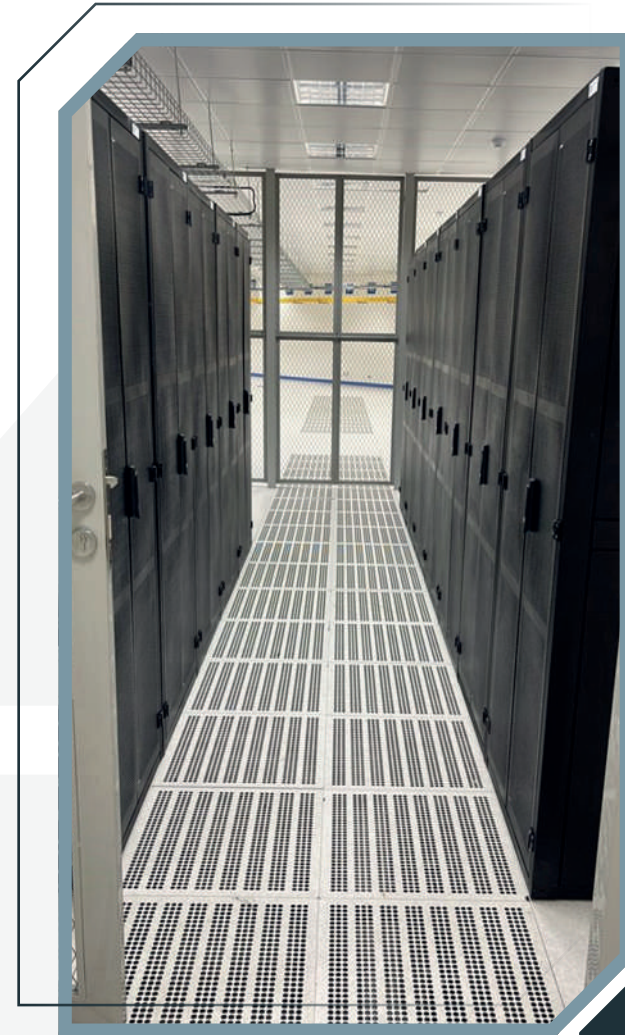

GAMMA DC FLEX DATA CENTER CABINETS SECTION

► Features:

- GAMMA DC Flex Data Center Cabinets Height : 42U /45U /47U
- Size (W X D) : 800 X 1000
- Made from Heavy Duty Steel Welded structure .
- Double door front and back full perforated
- Handle lock 3-point lock – (Optional Security lock with access card)
- Solid Split Side Doors,1 Key lock , with solid hinges
- Solid Top with Cable Inlet from Top front /back and side
- 2 Pair of 19" Mounting Rails depth Adjustable
- Static Load = 1100 kg
- 2 Pair of Transportation Caster Wheel and HD levelling feet
- Variety of options available on Request (please see optional Page)
- (Optional) Vertical Cable Management with Cover (2 pcs at front side)
- (Optional) 4 Fans, 105 CFM/Fan , 220 Volts
- (Optional) Brush for Cable Inlet
- (Optional) Security Access lock with card and key lock
- IP 20 Rated
- All Keys are alike
- Colour BLACK RAL 9005 , or Gray 7035 , other colours available on request
- Part # GMC-DC-FLEX-XXU-610 (XX = U Height)
- **MADE IN SAUDI ARABIA**

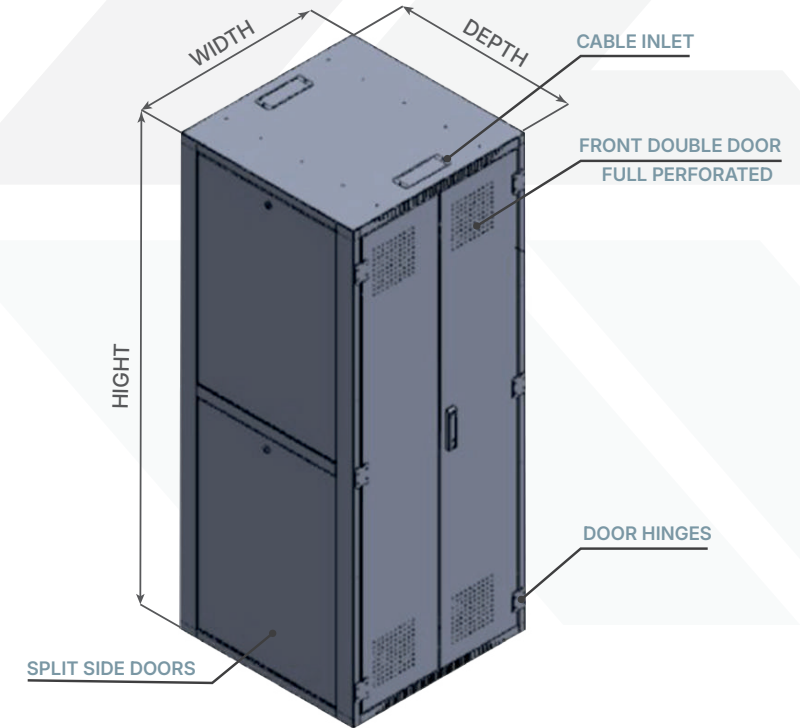

GAMMA DC FLEX DATA CENTER CABINETS (42U-45U-47U) 800 X 1000

Part Number	Description - Standard Configuration - Colour Black RAL 9005 (WELDED STRUCTURE)	Width (W) mm	Depth (D) mm		Depth Rail to Rail (mm)	Static Load (KG)
GMC-DC-FLEX-42U-810	Gamma DC Flex Data Center Cabinets 42U 800×1000 with Removable Solid Split Side Doors, Double door front and back full perforated , 2 pair of 19" Adjustable Pillars , 2 pair of caster Wheels	800	1000	2020	850	1100
GMC-DC-FLEX-45U-810	Gamma DC Flex Data Center Cabinets 45U 800×1000 with Removable Solid Split Side Doors, Double door front and back full perforated , 2 pair of 19" Adjustable Pillars , 2 pair of caster Wheels	800	1000	2160	850	1100
GMC-DC-FLEX-47U-810	Gamma DC Flex Data Center Cabinets 47U 800×1000 with Removable Solid Split Side Doors, Double door front and back full perforated , 2 pair of 19" Adjustable Pillars , 2 pair of caster Wheels	800	1000	2250	850	1100

OTHER SIZES AVAILABLE ON REQUEST

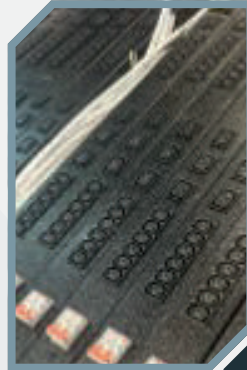

GAMMA VERTICAL PDU Models :

1. Basic PDU with Braker
2. Meter PDU with braker For Voltage and Amps and Watt
20 X C13 + 4 X C19 , 16 or 32 Amps (4 / 8 / 16 KW -220-250 V)
Power cord 1.8 m (3m option) Industrial Plug

ELECTRONIC LOCK WITH IC CARD (OPTIONAL)

Operation Instructions

1. After the controller powers on the electronic lock control wire, use the IC card to swipe the card in the designated swiping area. After the IC card matches the electronic lock, the green light flashes, and then press the circle position under the handle to turn on the electronic lock (if you don't press, The green light keeps flashing and waits for n seconds before the system automatically shuts down).
2. Rotate the handle to drive the steel bolt, connecting rod and other locking mechanisms to complete the opening action.
3. For key opening, first use the tool key to open the dust cover, then insert the key, and turn it clockwise to open the handle

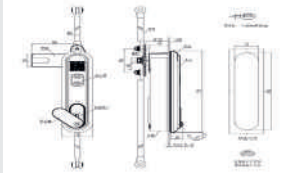

GAMMA DC FLEX DATA CENTER CABINETS (42U-45U-47U) 800 X 1200

◆ Standard Dimensions :

U-Height : 42U-45-47U

Width : 800 mm

Depth : 1200 mm

◆ Standard Colour :

RAL 9005
BLACK



RAL 7035
Light Gray



Other colours available
on request



◆ Complying with International Standards:

- ISO 9001-2015
- ISO 14001:2015
- EIA/ECA- 310 E & EIA-310 D
- IEC 297-1 19" MOUNTING
- IEC 297-2 Overall cabinet dimensions
- IP20 Protected
- MADE IN KSA

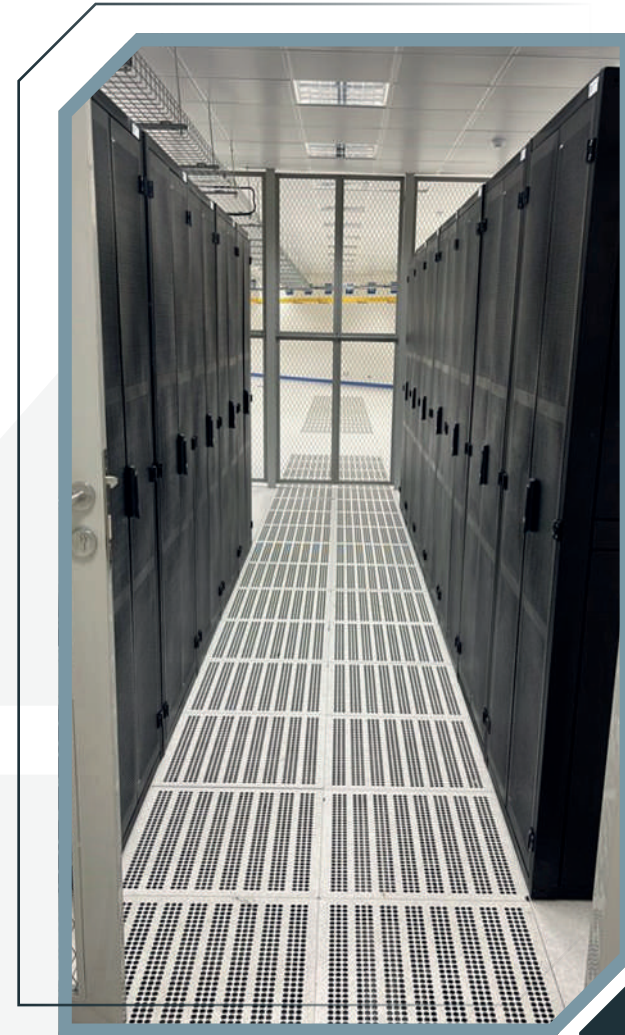

GAMMA DC FLEX DATA CENTER CABINETS SECTION

> Features:

- GAMMA DC Flex Data Center Cabinets Height : 42U /45U /47U
- Size (W X D) : 800 X 1200
- Made from Heavy Duty Steel Welded structure .
- Double door front and back full perforated
- Handle lock 3-point lock – (Optional Security lock with access card)
- Solid Split Side Doors,1 Key lock , with solid hinges
- Solid Top with Cable Inlet from Top front /back and side
- 2 Pair of 19" Mounting Rails depth Adjustable
- Static Load = 1100 kg
- 2 Pair of Transportation Caster Wheel and HD levelling feet
- Variety of options available on Request (please see optional Page)
- (Optional) Vertical Cable Management with Cover (2 pcs at front side)
- (Optional) 4 Fans, 105 CFM/Fan , 220 Volts
- (Optional) Brush for Cable Inlet
- (Optional) Security Access lock with card and key lock
- IP 20 Rated
- All Keys are alike
- Colour BLACK RAL 9005 , or Gray 7035 , other colours available on request
- Part # GMC-DC-FLEX-XXU-610 (XX = U Height)
- **MADE IN SAUDI ARABIA**

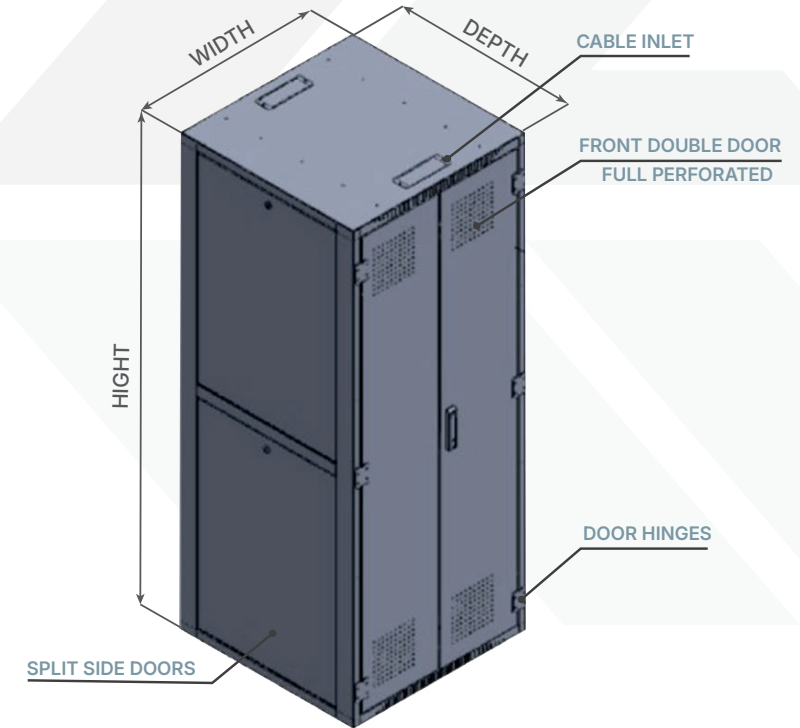

GAMMA DC FLEX DATA CENTER CABINETS (42U-45U-47U) 800 X 1200

Part Number	Description - Standard Configuration - Colour Black RAL 9005 (WELDED STRUCTURE)	Width (W) mm	Depth (D) mm	Height (H) mm	Depth Rail to Rail (mm)	Static Load (KG)
GMC-DC-FLEX-42U-812	Gamma DC Flex Data Center Cabinets 42U 800×1200 with Removable Solid Split Side Doors, Double door front and back full perforated , 2 pair of 19" Adjustable Pillars , 2 pair of caster Wheels	800	1200	2020	1050	1100
GMC-DC-FLEX-45U-812	Gamma DC Flex Data Center Cabinets 45U 800×1200 with Removable Solid Split Side Doors, Double door front and back full perforated , 2 pair of 19" Adjustable Pillars , 2 pair of caster Wheels	800	1200	2160	1050	1100
GMC-DC-FLEX-47U-812	Gamma DC Flex Data Center Cabinets 47U 800×1200 with Removable Solid Split Side Doors, Double door front and back full perforated , 2 pair of 19" Adjustable Pillars , 2 pair of caster Wheels	800	1200	2250	1050	1100

OTHER SIZES AVAILABLE ON REQUEST

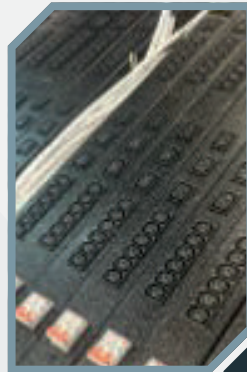

GAMMA VERTICAL PDU Models :

1. Basic PDU with Braker
2. Meter PDU with braker For Voltage and Amps and Watt
20 X C13 + 4 X C19 , 16 or 32 Amps (4 / 8 / 16 KW -220-250 V)
Power cord 1.8 m (3m option) Industrial Plug

ELECTRONIC LOCK WITH IC CARD (OPTIONAL)

Operation Instructions

1. After the controller powers on the electronic lock control wire, use the IC card to swipe the card in the designated swiping area. After the IC card matches the electronic lock, the green light flashes, and then press the circle position under the handle to turn on the electronic lock (if you don't press, The green light keeps flashing and waits for n seconds before the system automatically shuts down).
2. Rotate the handle to drive the steel bolt, connecting rod and other locking mechanisms to complete the opening action.
3. For key opening, first use the tool key to open the dust cover, then insert the key, and turn it clockwise to open the handle

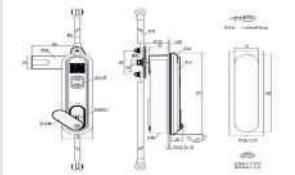

◆ GAMMA NET OPEN RACK CABINETS – 2 OR 4 POLE (22U-47U)

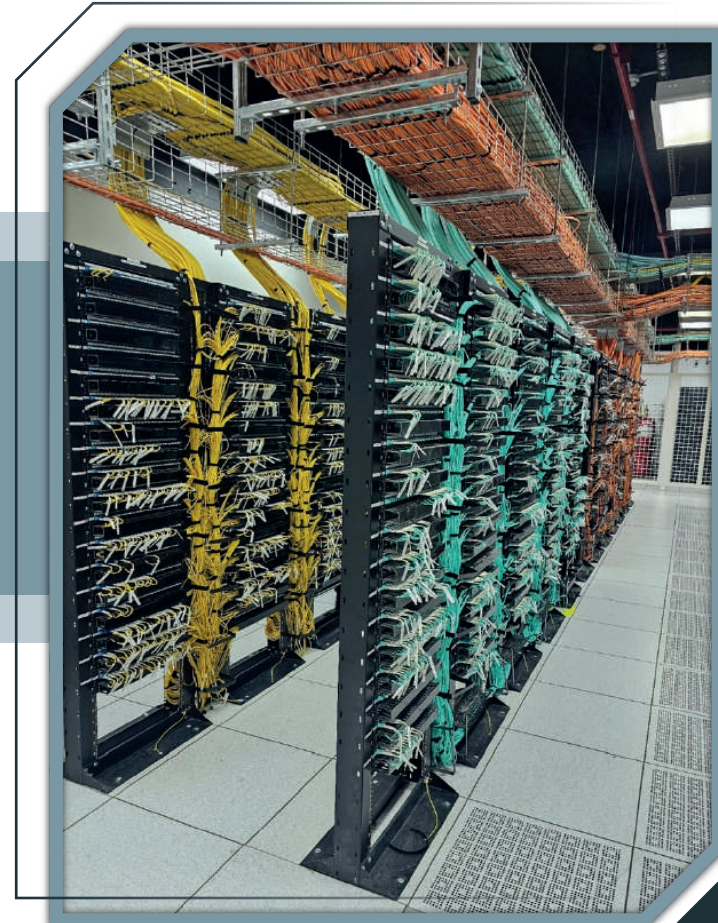

◆ GAMMA NET OPEN RACK CABINETS – 2 OR 4 POLE (22U-47U)

◆ Standard Dimensions :

Height	: 22U –47U
Width	: 510 mm
Depth	: 100 mm
No Of post	: 2 or 4 Post

◆ Standard Colour :

RAL 9005
BLACK



RAL 7035
Light Gray



Other colours available
on request



◆ Complying with International Standards:

- ISO 9001-2015
- ISO 14001:2015
- EIA/ECA- 310 E & EIA-310 D
- IEC 297-1 19" MOUNTING
- IEC 297-2 Overall cabinet dimensions
- IP20 Protected
- MADE IN KSA

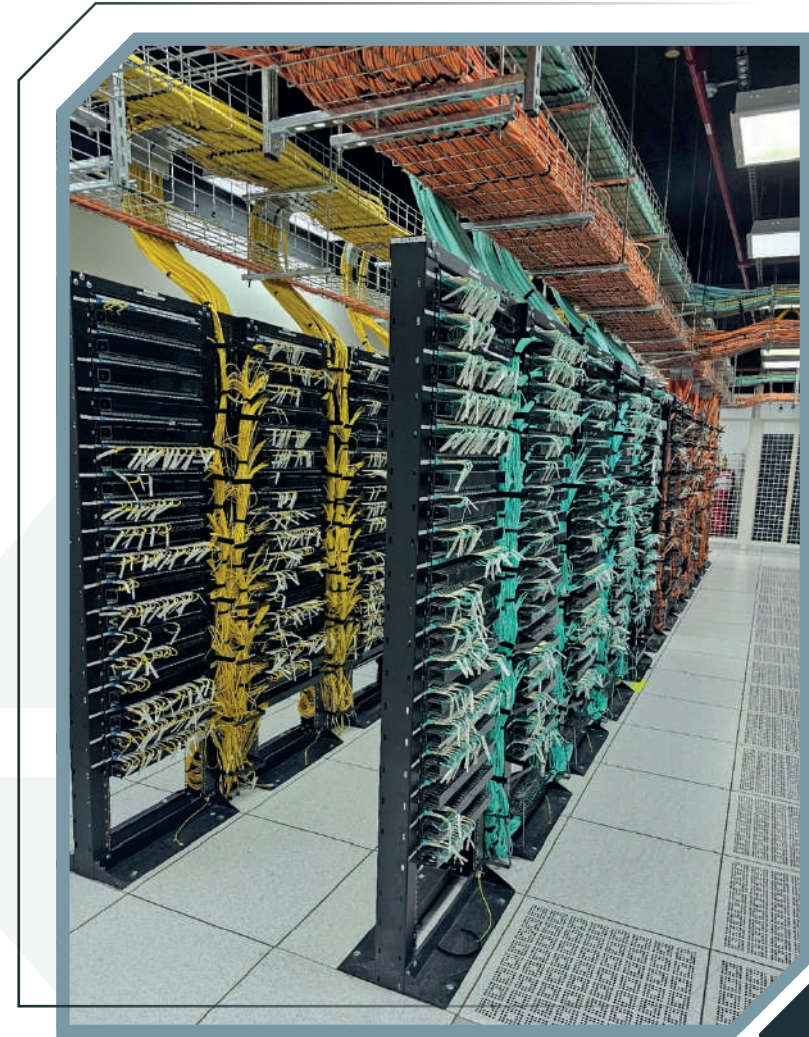

GAMMA NET FREE STAND CABINETS SECTION

> Features:

- Frame Made from Heavy Duty Steel structure
- Powder Coated Finish
- Size from 21U – 47 U
- 19" 2 Pole Frame or 4 Pole
- Static load 600 kg
- Base for ground fixing
- Optional Bus Bar for Earthing
- Optional Vertical cable Management at side
- Optional Cantilever Shelf
- Color Black RAL 9005 or Gray RAL 7035
- Other color available on Request
- **MADE IN SAUDI ARABIA**

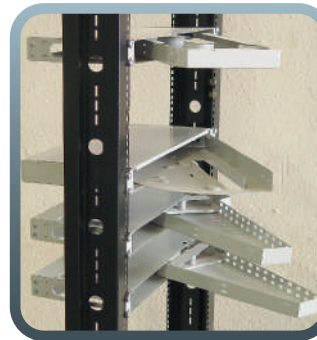

Open Rack	H	h	W	w
22 U	1125	22 U	514	450
36 U	1747	36 U	514	450
42 U	2013	42 U	514	450
45 U	2147	45 U	514	450

Abberviations : H- Overall Height, h- usable Height, W- Overall Width, w- usable width, 1U = 44.45MM

GAMMA OPEN RACK - 2 POLE

GAMMA OPEN RACK - 2 POLE

FRONT VIEW: Dimensions include 367, 367, 367, 367, 520, and 550.

SIDE VIEW: Dimensions include 310, 196.5, and 415.

TOP VIEW: Shows a rectangular layout with dimensions 550 and 415.

TITLE - OPEN RACK - 2 POLE ASSEMBLY		
DRAWN	SIRIAR	
CHECKED	ENG. JAMAL	
DATE	02 / 04 / 2000	REV : 00
SCALE	1:1	SHEET : 1/1
LOCATION	RIYADH, K.S.A.	
GAMMA FOR METAL INDUSTRIES		
P.O. BOX 29095 - RIYADH 11346		
TEL : +966 1 4628281 / 4628287		
FAX : +966 1 4628282		
E-MAIL : info@gamma.com.sa		

GAMMA OPEN RACK - 4 POLE - 19" INCH

FRONT VIEW: Dimension 19" INCH.

SIDE VIEW: Shows the profile of the rack.

TOP VIEW: Shows the layout of the four poles.

3D View: Shows the full assembly with dimensions 19", 415, and 550.

TITLE - OPEN RACK - 4 POLES ASSEMBLY		
DRAWN	SIRIAR	
CHECKED	ENG. JAMAL	
DATE	18 / 08 / 2005	REV : 00
SCALE	1:1	SHEET : 1/1
LOCATION	RIYADH, K.S.A.	
GAMMA FOR METAL INDUSTRIES		
P.O. BOX 29095 - RIYADH 11346		
TEL : +966 1 4628281 / 4628287		
FAX : +966 1 4628282		
E-MAIL : info@gamma.com.sa		

GAMMA OPEN RACK - 2 POLE - 19" INCH

FRONT VIEW: Dimension 19" INCH.

SIDE VIEW: Shows the profile.

ISOMETRIC VIEW: Shows the 3D structure with THK 2.5 mm.

TITLE - OPEN RACK - 2 POLE - 19"		
DRAWN	SIRIAR	
CHECKED	ENG. JAMAL	
DATE	18 / 08 / 2005	REV : 00
SCALE	1:1	SHEET : 1/1
LOCATION	RIYADH, K.S.A.	
GAMMA FOR METAL INDUSTRIES		
P.O. BOX 29095 - RIYADH 11346		
TEL : +966 1 4628281 / 4628287		
FAX : +966 1 4628282		
E-MAIL : info@gamma.com.sa		

FRONT VIEW: Dimension 19" INCH.

SIDE VIEW: Dimensions include 2200, 800, and 1300.

TOP VIEW: Shows the layout of the four poles.

3D View: Shows the full assembly with THICKNESS 1.5 mm and VCM.

ALL DIMENSIONS ARE IN mm

TITLE - OPEN RACK - 4 POLES ASSEMBLY - 48 U		
DRAWN	SIRIAR	
CHECKED	ENG. JAMAL	
DATE	04 / 02 / 2003	REV : 00
SCALE	1:1	SHEET : 1/1
LOCATION	RIYADH, K.S.A.	
GAMMA FOR METAL INDUSTRIES		
P.O. BOX 29095 - RIYADH 11346		
TEL : +966 1 4628281 / 4628287		
FAX : +966 1 4628282		
E-MAIL : info@gamma.com.sa		



GAMMA NET FREE STAND RACK CABINETS



◆ GAMMA NET FREE STAND RACK CABINETS (42U-45U-47U) – COMPARTMENT

◆ Standard Dimensions :

U-Height : 42U -45U- 47U

Width : 800 mm

Depth : 1000/1200 mm

◆ Standard Colour :

RAL 9005
BLACK



RAL 7035
Light Gray



Other colours available
on request



◆ Complying with International Standards:

- ISO 9001-2015
- ISO 14001:2015
- EIA/ECA- 310 E & EIA-310 D
- IEC 297-1 19" MOUNTING
- IEC 297-2 Overall cabinet dimensions
- IP20 Protected
- MADE IN KSA

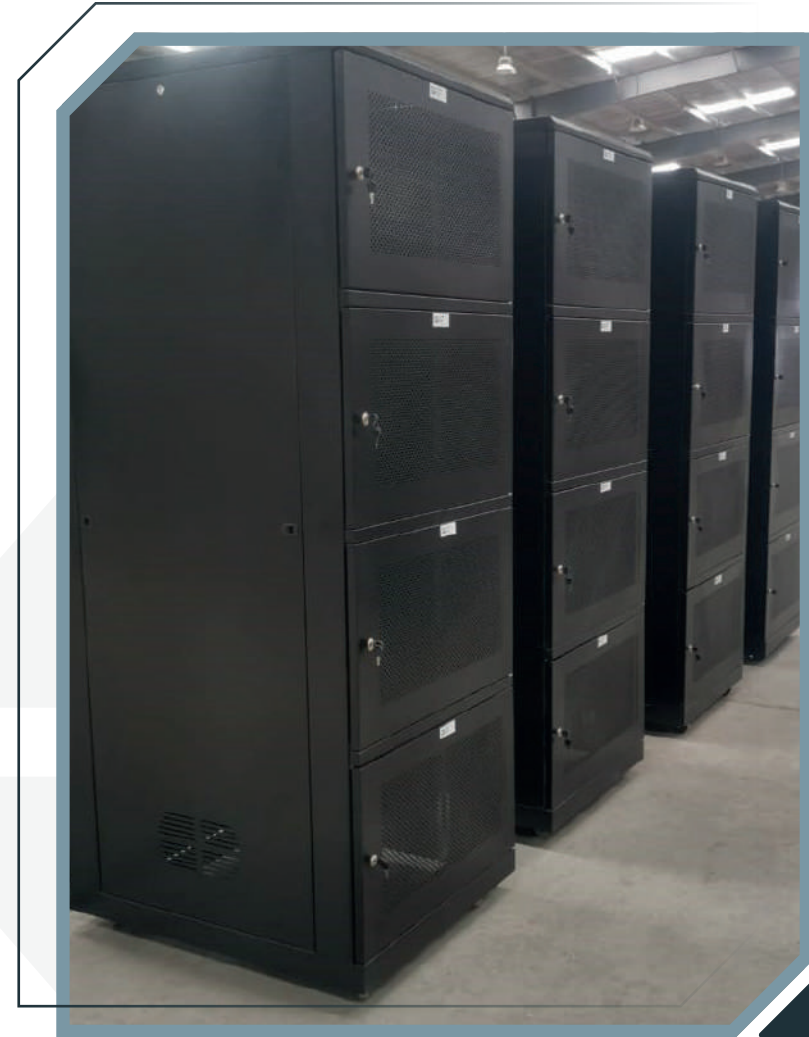

◆ GAMMA NET FREE STAND CABINETS – COMPARTMENT SECTION

➤ Features:

- GAMMA Data Cabinets – COMPARTMENT
- Made from Steel Welded Frame
- Front and Back glass compartment doors – Optional single or double perforated doors
- Compartment Cabinet – custom design – 2/3/4 compartment as per customer request
- Every Compartment have different Key lock -Optional Digital Security lock
- No interface between compartment
- Vertical Cable Management with Cover (2 pcs at front side) for every compartment
- 4 Fans, 100 CFM/Fan , 220 Volts
- Removable Single Side door with key lock and latch (optional compartment)
- 2 Pair of 19" Mounting Rails depth Adjustable for every compartment
- Static Load = 800 kg
- Variety of options available on Request (please see optional Page)
- 2 Pair of Transportation Caster Wheel
- Cable Inlet from Top & Bottom
- IP 20 Rated (IP54 available as optional on request)
- Color BLACK RAL 9005 , or Grau 7035 , other colors available on request
- **MADE IN SAUDI ARABIA**



Optional :
Digital Lock for every compartment Number lock

GAMMA NET FREE STAND RACK CABINETS SIZE 42U - 45U - 47U (800X1000)

Part Number	Description - Standard Configuration - Colour Black RAL 9005 (WELDED STRUCTURE)	Width (W) mm	Depth (D) mm	Height (H) mm	Depth Rail to Rail (mm)	Static Load (KG)
GMC-FR-42U-810-4F	Gamma Net Free Stand Compartment Cabinet 42U 800×1000 with Removable single Side Door (compartment side door available as option) , Front and Back door perforated for every compartment with unlike key lock , Pair of Vertical cable management for every compartment , 2 pair of 19" Adjustable Pillars , 2 pair of caster Wheels , 4 Fan	800	1000	2020	600	800
GMC-FR-45U-810-4F	Gamma Net Free Stand Compartment Cabinet 45U 800×1000 with Removable single Side Door (compartment side door available as option) , Front and Back door perforated for every compartment with unlike key lock , Pair of Vertical cable management for every compartment , 2 pair of 19" Adjustable Pillars , 2 pair of caster Wheels , 4 Fan	600	1000	2160	600	800
GMC-FR-47U-810-4F	Gamma Net Free Stand Compartment Cabinet 47U 800×1000 with Removable single Side Door (compartment side door available as option) , Front and Back door perforated for every compartment with unlike key lock , Pair of Vertical cable management for every compartment , 2 pair of 19" Adjustable Pillars , 2 pair of caster Wheels , 4 Fan	600	1000	2250	600	800

OTHER SIZES AVAILABLE ON REQUEST

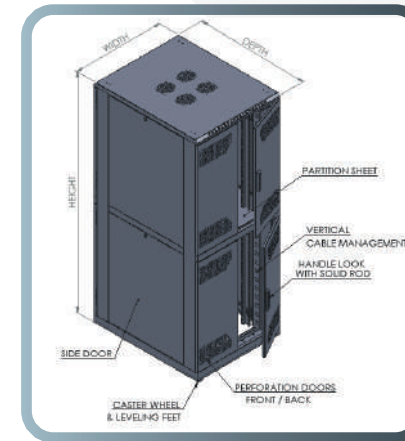
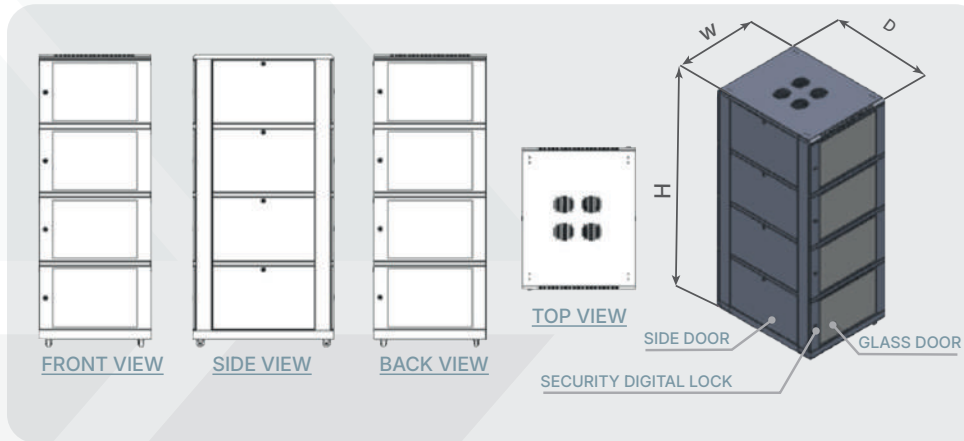

◆ GAMMA NET FREE STAND RACK CABINETS – IP 54 (36U-42U-45U-47U)

◆ Standard Dimensions :

U-Height : 36U-42U-45-47U

Width : 600/800 mm

Depth : 800/1000/1200 mm

◆ Standard Colour :

RAL 9005
BLACK



RAL 7035
Light Gray



Other colours available
on request



◆ Complying with International Standards:

- ISO 9001-2015
- ISO 14001:2015
- EIA/ECA- 310 E & EIA-310 D
- IEC 297-1 19" MOUNTING
- IEC 297-2 Overall cabinet dimensions
- IP54 Protected
- MADE IN KSA



◆ GAMMA NET FREE STAND RACK CABINETS SECTION

➤ Features:

- GAMMA Data Cabinets IP54
- Made from Galvanized Steel Welded Frame .
- Front Glass Door with swing Handle Lock
- Back door with Key lock and Ventilation fans with air filters
- Removable Side Doors,1 Key lock and 2 Plastic Latched each side and filters
- Cable Inlet from Top & Bottom with removable cover and casket
- 4 Fans, 100 CFM/Fan , 220 Volts at back side with air filters
- 2 Pair of 19" Mounting Rails depth Adjustable
- 1 Pair of Metal Vertical Cable Management with Cover at front side (option)
- Static Load = 800 kg
- Variety of options available on Request (please see optional Page)
- 2 Pair of Transportation Caster Wheel
- All Keys are alike
- IP 54 Rated
- Color BLACK RAL 9005 , or Grau 7035 , other colors available on request
- **MADE IN SAUDI ARABIA**

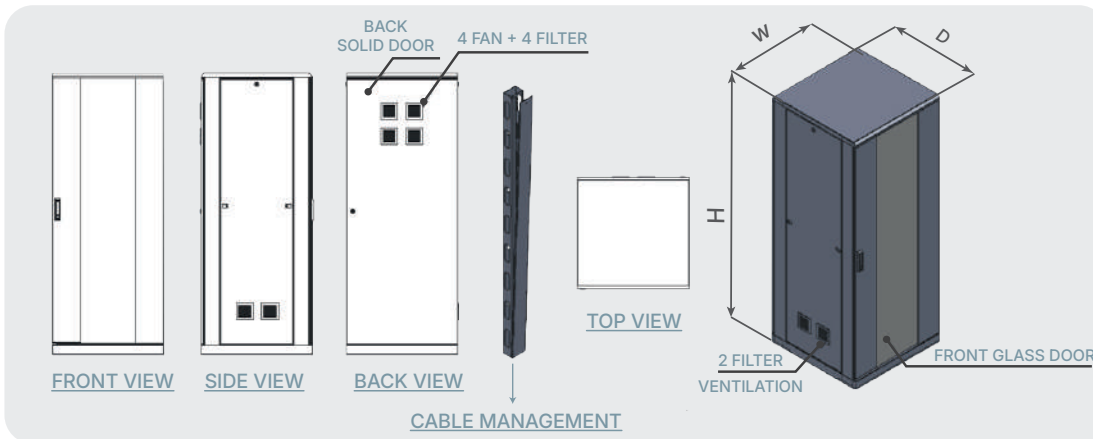

GAMMA DbA FREE STAND CABINETS – CUSTOM MADE SOUNDPROOF CABINETS

◆ Standard Dimensions :

U-Height : Custom Made Cabinets

Width : 600/800 mm

Depth : 800/1000/1200 mm

◆ Standard Colour :

RAL 9005
BLACK



RAL 7035
Light Gray



Other colours available
on request



◆ Complying with International Standards:

- ISO 9001-2015
- ISO 14001:2015
- EIA/ECA- 310 E & EIA-310 D
- IEC 297-1 19" MOUNTING
- IEC 297-2 Overall cabinet dimensions
- IP54 Protected
- MADE IN KSA

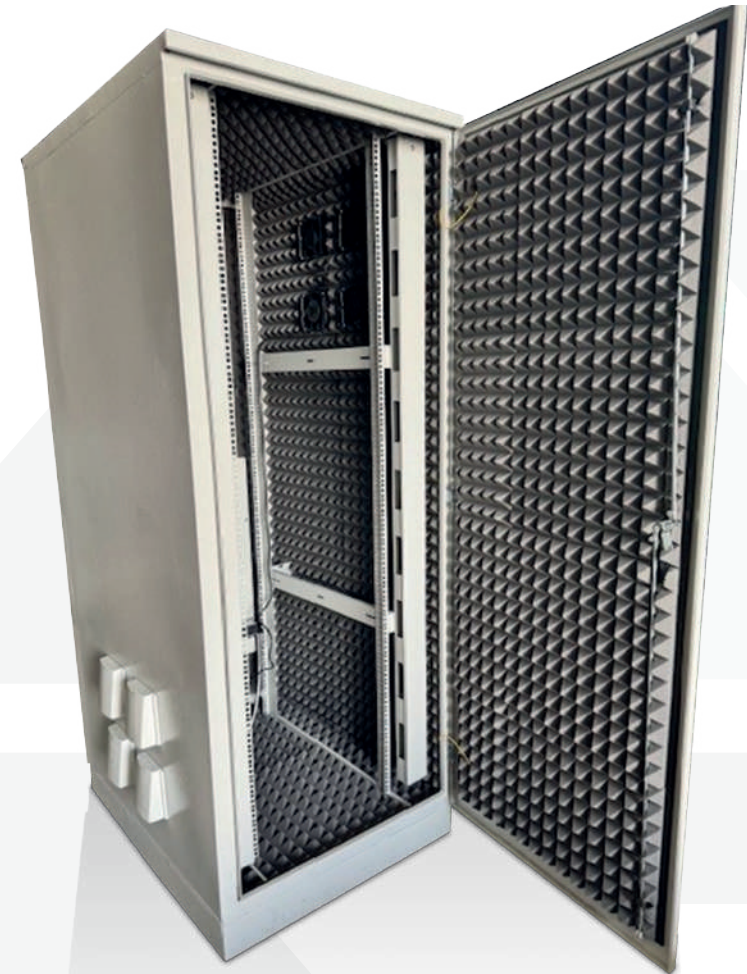

◆ GAMMA DbA FREE STAND CABINETS SECTION

› Features:

- GAMMA Data Cabinets Custom Made Soundproof Cabinets
- Made from Steel Welded Frame .
- Front Glass Door with swing Handle Lock
- Back door with Key lock and Ventilation fans with air filters
- Removable Side Doors,1 Key lock and 2 Plastic Latched each side and filters
- Up to 40 % noise reduction
- Cable Inlet from Top & Bottom with removable cover and casket
- 4 Fans, 100 CFM/Fan , 220 Volts at back side with air filters
- 2 Pair of 19" Mounting Rails depth Adjustable
- 1 Pair of Metal Vertical Cable Management with Cover at front side (option)
- Static Load = 800 kg
- Variety of options available on Request (please see optional Page)
- 2 Pair of Transportation Caster Wheel
- All Keys are alike
- IP 54 Rated
- Color BLACK RAL 9005 , or Grau 7035 , other colors available on request
- **MADE IN SAUDI ARABIA**

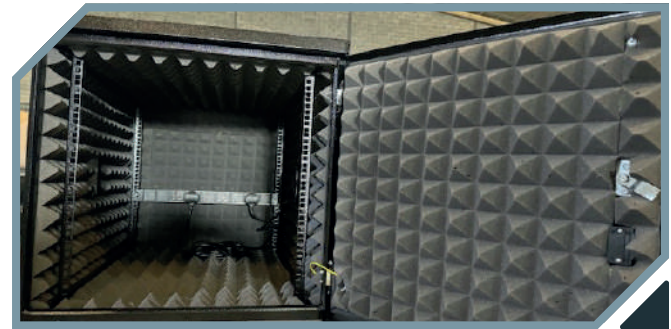
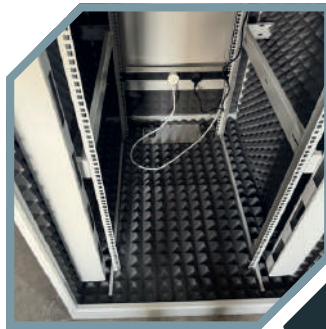
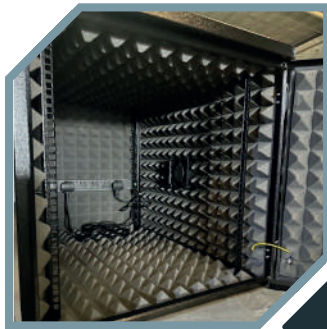
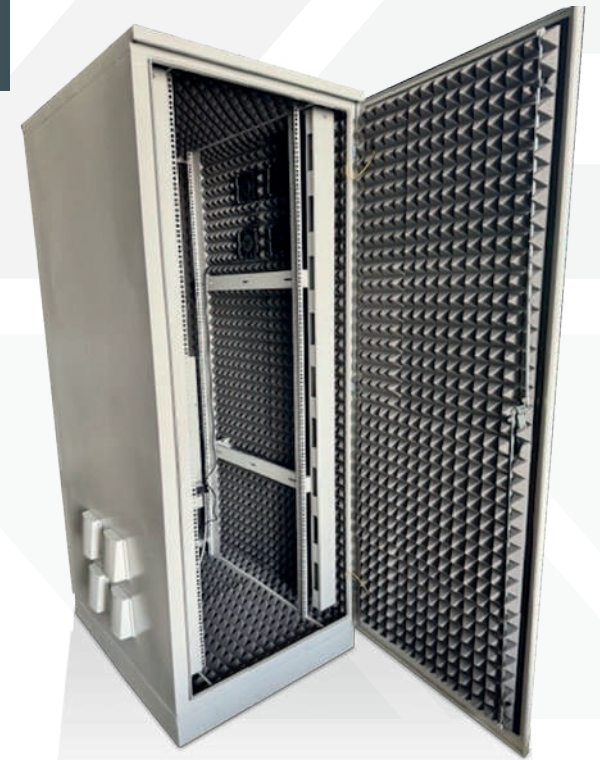

GAMMA OUTDOOR CABINETS



GAMMA 19" OUTDOOR IP RACK CABINETS Wall Mount and Pole Mount



◆ GAMMA 19" OUTDOOR IP RACK CABINETS WALL MOUNT AND POLE MOUNT

◆ Standard Dimensions :

Height : 6U / 9U/ 12U/ 15U/ 18U/ 21U

Width : 600 mm

Depth : 600/800 mm

◆ Standard Colour :

RAL 7035
Light Gray



Other colours available
on request



◆ Complying with International Standards:

- ISO 9001-2015
- ISO 14001:2015
- EIA/ECA- 310 E & EIA-310 D
- IEC 297-1 19" MOUNTING
- IEC 297-2 Overall cabinet dimensions
- IP66 Protected
- MADE IN KSA



◆ GAMMA NEW GENERATION SECURITY OUTDOOR CABINET – IP PROTECTION

➤ 1.0 Gamma Outdoor General Features :

1- Security Cabinet: GAMMA Security Cabinets with Pole mount version enable protecting your valuable and sensitive equipment's with its unique design. It is well protected against rain, snow, wind, sun radiation With its perfect resistance against to corrosion, protects your technological investments against environmental effects. Overall, between the inner and outer skin there is an Optional isolation rubber material or Aluminium foil to prevent skin heat to go inside cabinet

2- Cabinet Structure: Structure made from Galvanized steel material, with high corrosion resistance and polyester outdoor electrostatic Powder Coated painting through fully Automated 6 stages pretreatment Powder coating line with Robotic spraying Guns

3- Filter and Fan System: The cabinet has a replaceable 1 or 2 filter housing with Canopy at right side , which eliminates water and dust entry while allowing fresh air entry to the cabinet. The left side of the cabinet is equipped with 1 or 2 fan with filters. The Single cycle fan system allows fresh air entry from right side and discharge from left side accumulated heat from the ventilation filters back of the fans .

4- Rain Canopy at top of the cabinet for double protection from rain

5- Painting: Outdoor style polyester paint through fully Automated 6 stages pretreatment Powder coating line with Robotic spraying Guns applied to resist environmental corrosive effects. It also resists to sun radiation. Standard applied colour is RAL7035 Light Grey.

6- Optional Sunshade 50 mm – 100 mm sunshade over the rain canopy for more heat reduction in case of direct sun all day to eliminate direct heat of cabinet skin

7- Front Door Structure and Lock System: Hidden 3 hinge, fixed on front door and 1 or 2 key lock depend on cabinet size . With gasket, the front door provides maximum safety and sealing when the door is closed.. It has a sealing gasket structure, provides excellent IP protection even cold / hot weather condition.

8- Mounting Plate : Pair of 19" Mounting Pillars are provided according to cabinet design

9- Optional isolated Skin Structure: Isolated Skin protects the equipment's inside cabinet from external effects, and harsh environmental conditions.



GAMMA OUTDOOR IP RATED WITH 19" Pillars Wall /Pole Mount Metal CABINET

Part Number	Standard Description (W X H X D) mm	Depth (D)
GMC-OD-WMS-6U-66-1F	6U Wall mounting steel enclosures size 600X600 1 door IP 65 with 4 19 inch Pillars – 1 Fan	600
GMC-OD-WMS-6U-68-1F	6U Wall mounting steel enclosures size 600X800 1 door IP 65 with 4 19 inch Pillars – 1 Fan	800
GMC-OD-WMS-9U-66-1F	9U Wall mounting steel enclosures size 600X600 1 door IP 65 with 4 19 inch Pillars – 1 Fan	600
GMC-OD-WMS-9U-68-1F	9U Wall mounting steel enclosures size 600X800 1 door IP 65 with 4 19 inch Pillars – 1 Fan	800
GMC-OD-WMS-12U-66-1F	12U Wall mounting steel enclosures size 600X600 1 door IP 65 with 4 19 inch Pillars – 1 Fan	600
GMC-OD-WMS-12U-68-1F	12U Wall mounting steel enclosures size 600X800 1 door IP 65 with 4 19 inch Pillars – 1 Fan	800
GMC-OD-WMS-15U-66-1F	15U Wall mounting steel enclosures size 600X600 1 door IP 65 with 4 19 inch Pillars – 1 Fan	600
GMC-OD-WMS-15U-68-2F	15U Wall mounting steel enclosures size 600X800 1 door IP 65 with 4 19 inch Pillars – 2 Fan	800
GMC-OD-WMS-18U-66-1F	18U Wall mounting steel enclosures size 600X600 1 door IP 65 with 4 19 inch Pillars – 1 Fan	600
GMC-OD-WMS-18U-68-2F	18U Wall mounting steel enclosures size 600X800 1 door IP 65 with 4 19 inch Pillars – 2 Fan	800
GMC-OD-WMS-21U-66-1F	21U Wall mounting steel enclosures size 600X600 1 door IP 65 with 4 19 inch Pillars – 1 Fan	600
GMC-OD-WMS-21U-68-2F	21U Wall mounting steel enclosures size 600X800 1 door IP 65 with 4 19 inch Pillars – 2 Fan	800

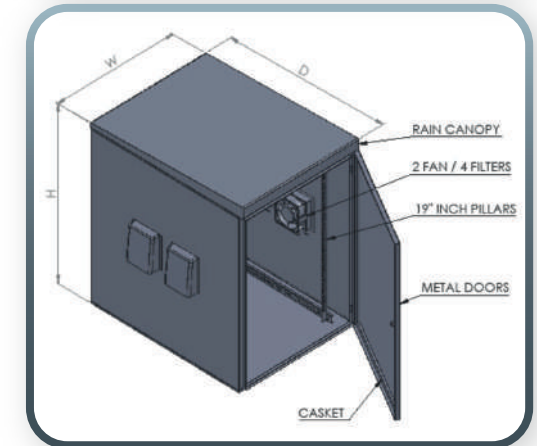
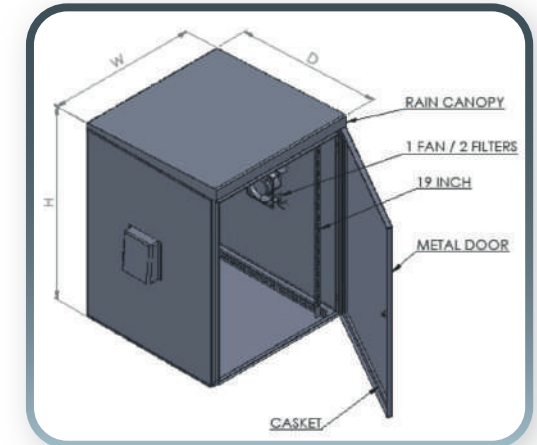

GAMMA OUTDOOR IP RATED WALL/Pole Metal CABINET & Enclosures

GAMMA OUTDOOR IP RATED WITH MOUNTING PLATE (MP) Wall /Pole Mount Metal Enclosures

Part Number	Standard Description (W X H X D) mm	MP SIZE (WXH) mm	Depth (D)
GMC-OD-WMS-4040-25-1F	Wall/Pole Mounting Enclosures size 400X400X250 1 door IP 66 with Mounting Plate - 1 FAN	300 × 300	250
GMC-OD-WMS-5050-25-1F	Wall/Pole Mounting Enclosures size 500X500X250 1 door IP 66 with Mounting Plate - 1 FAN	400 × 400	250
GMC-OD-WMS-6060-25-1F	Wall/Pole Mounting Enclosures size 600X600X200 1 door IP 66 with Mounting Plate - 1 FAN	500 × 500	250
GMC-OD-WMS-7070-25-2F	Wall/Pole Mounting Enclosures size 700X700X250 1 door IP 66 with Mounting Plate - 2 FAN	600 × 600	250
GMC-OD-WMS-8080-30-2F	Wall/Pole Mounting Enclosures size 800X800X250 1 door IP 66 with Mounting Plate - 2 FAN	700 × 700	300
GMC-OD-WMS-80100-30-2F	Wall/Pole Mounting Enclosures size 800X1000X300 1 door IP 66 with Mounting Plate - 2 FAN	700 × 900	300
GMC-OD-WMS-80120-30-2F	Wall/Pole Mounting Enclosures size 800X1200X300 1 door IP 66 with Mounting Plate - 2 FAN	700 × 1100	300

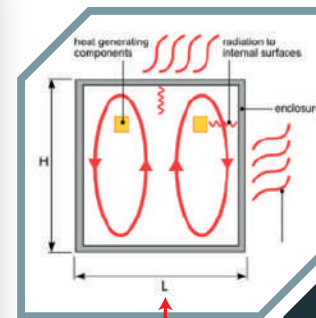
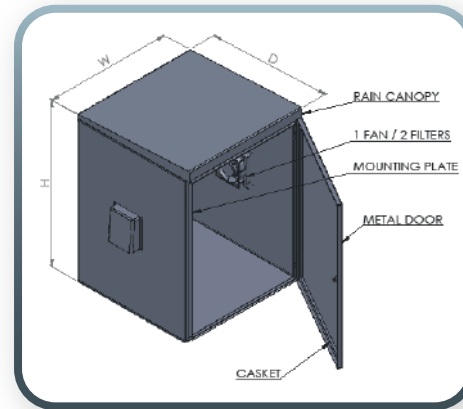
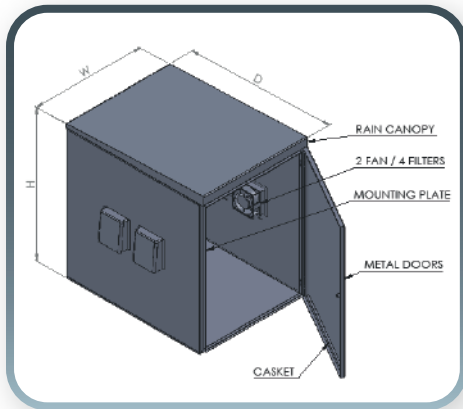

Enclosure without FAN

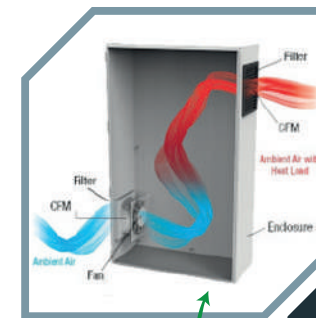

Enclosure with FAN

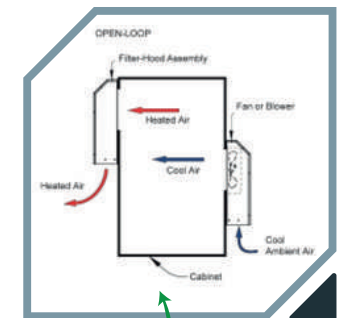

GAMMA 19" OUTDOOR IP RACK CABINETS FREE STAND



◆ GAMMA 19" OUTDOOR IP RACK CABINETS FREE STAND

◆ Standard Dimensions :

Height : 6U / 9U/ 12U/ 15U/ 18U/ 21U

Width : 600 /800 mm

Depth : 600 /800 mm

◆ Standard Colour :

RAL 7035
Light Gray



Other colours available
on request



◆ Complying with International Standards:

- ISO 9001-2015
- ISO 14001:2015
- EIA/ECA- 310 E & EIA-310 D
- IEC 297-1 19" MOUNTING
- IEC 297-2 Overall cabinet dimensions
- IP66 Protected
- MADE IN KSA



◆ GAMMA NEW GENERATION SECURITY OUTDOOR CABINET – IP PROTECTION

➤ Gamma Outdoor General Features :

1- Security Cabinet: GAMMA Security Cabinets with Pole mount version enable protecting your valuable and sensitive equipment's with its unique design. It is well protected against rain, snow, wind, sun radiation With its perfect resistance against to corrosion, protects your technological investments against environmental effects. Overall, between the inner and outer skin there is an Optional isolation rubber material or Aluminium foil to prevent skin heat to go inside cabinet

2- Cabinet Structure: Structure made from Galvanized steel material, with high corrosion resistance and polyester outdoor electrostatic Powder Coated painting through fully Automated 6 stages pretreatment Powder coating line with Robotic spraying Guns

3- Filter and Fan System: The cabinet has a replaceable 1 or 2 filter housing with Canopy at right side , which eliminates water and dust entry while allowing fresh air entry to the cabinet. The left side of the cabinet is equipped with 1 or 2 fan with filters. The Single cycle fan system allows fresh air entry from right side and discharge from left side accumulated heat from the ventilation filters back of the fans .

4- Rain Canopy at top of the cabinet for double protection from rain

5- Painting: Outdoor style polyester paint through fully Automated 6 stages pretreatment Powder coating line with Robotic spraying Guns applied to resist environmental corrosive effects. It also resists to sun radiation. Standard applied colour is RAL7035 Light Grey.

6- Optional Sunshade 50 mm – 100 mm sunshade over the rain canopy for more heat reduction in case of direct sun all day to eliminate direct heat of cabinet skin

7- Front Door Structure and Lock System: Hidden 3 hinge, fixed on front door and 1 or 2 key lock depend on cabinet size . With gasket, the front door provides maximum safety and sealing when the door is closed.. It has a sealing gasket structure, provides excellent IP protection even cold / hot weather condition.

8- Mounting Plate or 19" : Pair of 19" Pillars or MP are provided according to customer

9- Optional isolated Skin Structure: Isolated Skin protects the equipment's inside cabinet from external effects, and harsh environmental conditions.



GAMMA NET OUTDOOR IP RATED 19" Floor Stand Metal Enclosures

Part Number	Standard Description (W X H X D) mm	Depth (D)
GMC-OD-FR-6U-66-1F	6U Free Stand steel enclosures size 600X600 1 door IP 65 with 4 19 inch Pillars -Plinth 50 mm -1 Fan	600
GMC-OD-FR-6U-68-1F	6U Free Stand steel enclosures size 600X800 1 door IP 65 with 4 19 inch Pillars -Plinth 50 mm-1 Fan	800
GMC-OD-FR-9U-66-1F	9U Free Stand steel enclosures size 600X600 1 door IP 65 with 4 19 inch Pillars -Plinth 50 mm-1 Fan	600
GMC-OD-FR-9U-68-1F	9U Free Stand steel enclosures size 600X800 1 door IP 65 with 4 19 inch Pillars -Plinth 50 mm-1 Fan	800
GMC-OD-FR-12U-66-1F	12U Free Stand steel enclosures size 600X600 1 door IP 65 with 4 19 inch Pillars -Plinth 50 mm-1 Fan	600
GMC-OD-FR-12U-68-1F	12U Free Stand steel enclosures size 600X800 1 door IP 65 with 4 19 inch Pillars-Plinth 50 mm-1 Fan	800
GMC-OD-FR-15U-66-1F	15U Free Stand steel enclosures size 600X600 1 door IP 65 with 4 19 inch Pillars -Plinth 50 mm-1 Fan	600
GMC-OD-FR-15U-68-2F	15U Free Stand steel enclosures size 600X800 1 door IP 65 with 4 19 inch Pillars-Plinth 50 mm-2 Fan	800
GMC-OD-FR-21U-66-2F	21U Free Stand steel enclosures size 600X600 1 door IP 65 with 4 19 inch Pillars -Plinth 50 mm-2 Fan	600
GMC-OD-FR-21U-68-2F	21U Free Stand steel enclosures size 600X800 1 door IP 65 with 4 19 inch Pillars -Plinth 50 mm-2 Fan	800
GMC-OD-FR-21U-88-2F	21U Free Stand steel enclosures size 800X800 1 door IP 65 with 4 19 inch Pillars -Plinth 50 mm-2 Fan	800

OTHER SIZES AVAILABLE ON REQUEST

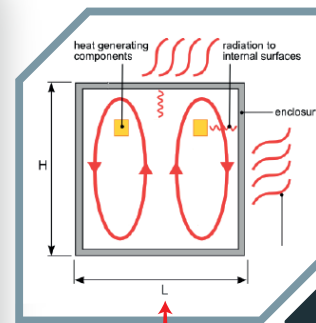
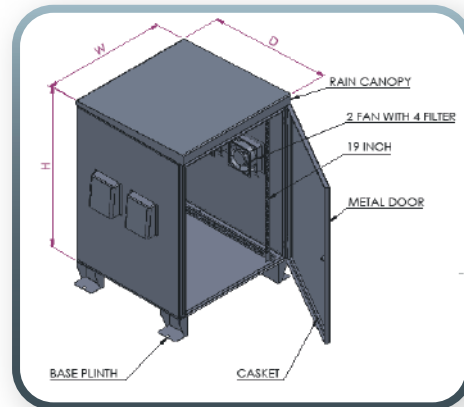
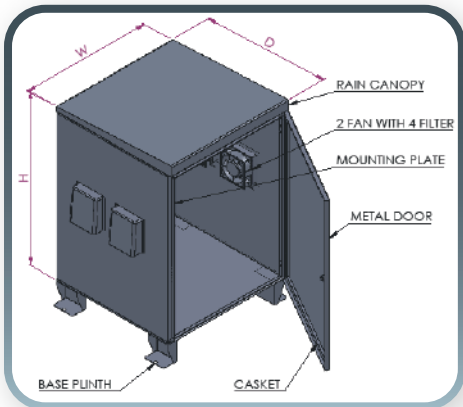

Enclosure without FAN

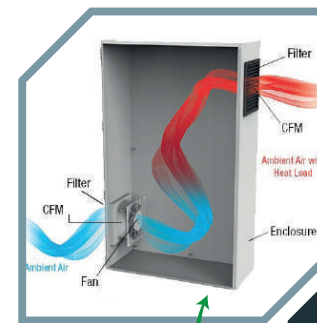

Enclosure with FAN

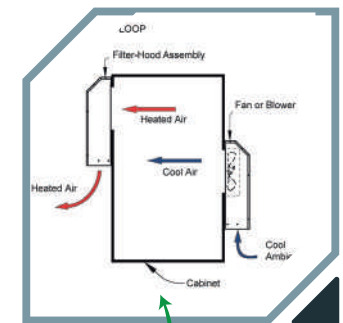

◆ GAMMA OD TEST REPORT – WATER PROOF

- **Test product :** GAMMA OUTDOOR CABINETS IP66
- **Manufacturer :** GAMMA FACTORY FOR METAL INDS. KSA
- **Cabinet Size :** 500 X 700 X 250 mm
- **Cabinet Data Include :** Rubber Inside Isolation
2 Fans with Filter,
2 Air Inlet Filters, Rain Canopy
Sabic Galvanized Steel GI – G90
- **Test Duration :** 15 min
- **Test Type :** High Pressure water from all Direction
- **Number of Water Nozzles :** 76 Nozzles x 14 mm Water Pipe

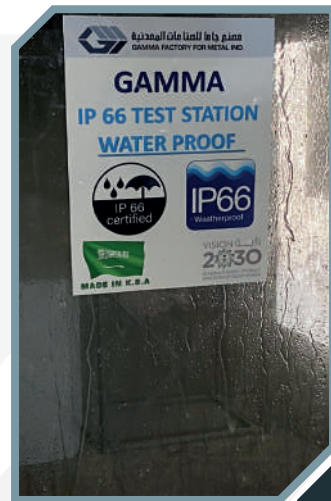

◆ GAMMA OD TEST REPORT – FAN TEST

Test product : GAMMA OUTDOOR CABINETS IP66
Manufacturer : GAMMA FACTORY FOR METAL INDS. KSA
Cabinet Size : 500 X 700 X 250 mm
Cabinet Data Include : Rubber Inside Isolation
 2 Fans with Filter,
 2 Air Inlet Filters, Rain Canopy
 Sabc Galvanized Steel GI – G90
Test Duration : 60 min
Test Type : Fan Heat Dissipation
Heat Load : 200 Watt
Test Room : Normal Room Environments

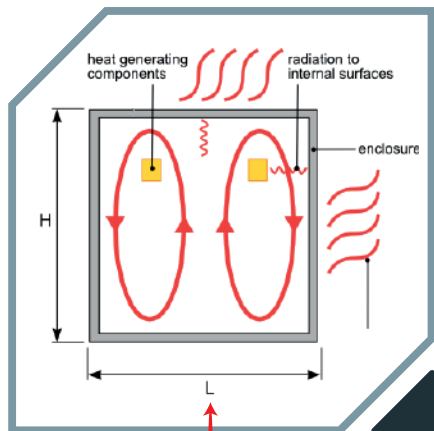

Enclosure without FAN

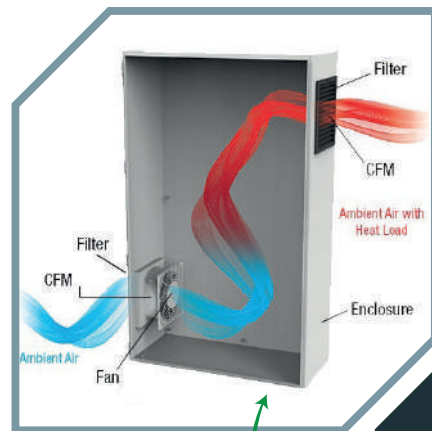

Enclosure with FAN

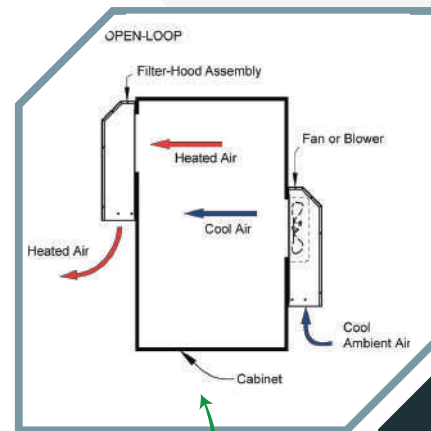

GAMMA OD TEST REPORT –FAN TEST

1



Heat Source OFF & Fan OFF
Inside Temp. = 30 C
Outside Temp. = 31 C

2



Heat Source ON / Fan OFF
Inside Temp. = 40 C
Duration : 15 min
Outside Temp. = 30 C

3



Heat Source ON / Fan ON
Inside Temp. = 37 C
Duration : 10 min
Outside Temp. = 31 C

4



Heat Source ON / Fan ON
Inside Temp. = 34 C
Duration : 15 min
Outside Temp. = 31 C

5



Heat Source ON / Fan ON
Inside Temp. = 32 C
Duration : 5 min
Outside Temp. = 32 C

6



Heat Source ON / Fan ON
Inside Temp. = 33 C
Duration : 5 min
Outside Temp. = 33 C

GAMMA FEC CABINETS IP66 FLOOR STAND WITH AIR CONDITIONING & MONITORING INTERFACE



GAMMA FEC CABINETS IP66 FLOOR STAND

◆ Dimensions :

Height : 21U / 26U / 32U / 42 U
Width : 800 / 1350 mm
Depth : 800/1000 mm

◆ Standard Colour :

RAL 7035
Light Gray



Other colours available
on request



◆ Complying with International Standards:

- ISO 9001:2015 /ISO 14001:2015 / ISO 4500:2018
- EIA/ECA- 310 E & EIA-310 D
- IEC 297-1 19" MOUNTING
- IEC 297-2 Overall cabinet dimensions
- IP66 / IK08 Protected for Cabinet
- Local Content Certificate
- MADE IN KSA

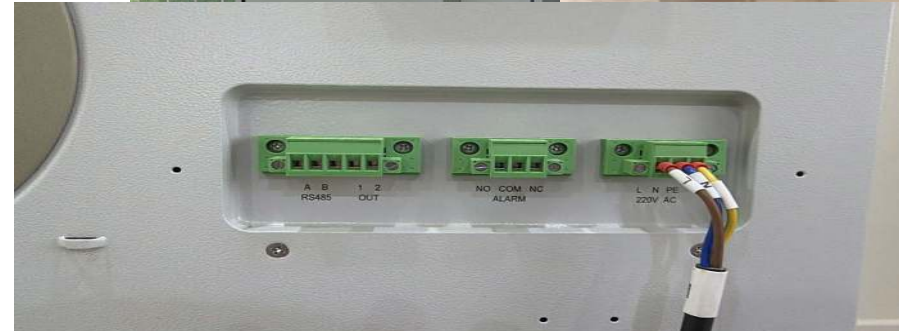

◆ GAMMA FIELD EQUIPMENT CABINET (FEC) – IP66 PROTECTION

➤ Features & Specifications

1. GAMMA FEC Cabinets with floor stand design are engineered to protect valuable and sensitive equipment with a robust and reliable enclosure system, offering protection against rain, dust, wind, and sun radiation.
2. FEC Cabinet Structure Manufactured from high-quality galvanized steel with powder coated finish for enhanced corrosion resistance , double skin insulation and rubber seal(Option : Stainless Steel) using CNC laser cut / CNC Robotic Bending /CNC Laser Welding and finished electrostatic powder coating fully automated line with 6-stage pretreatment and robotic spray guns.
3. Advanced Cooling System (Air Conditioner) -(Refer to data sheet for more details)
Recently introduced by GAMMA to meet evolving customer requirements for RS485-based remote monitoring and enhanced temperature management. Available in two models: GMI-AC0600W and GMI-AC2000W, based on customer cooling capacity requirements.
4. Rain Canopy
Integrated top rain canopy provides additional protection against water ingress and improves overall outdoor durability.
5. Front and Back Door Structure and Lock System
Heavy-duty front and back door with hidden hinges and secure handle lock system, designed to ensure sealing performance, and maintenance access.
6. Flexible Mounting Options
Mounting Plate (MP) or 19-inch rack mounting can be provided according to customer requirements.
7. Environmental Protection
Designed to withstand harsh FEC conditions IP66 with excellent resistance against moisture, dust, and high ambient temperatures.
8. Alarm Interface
GMI cooling unit models (GMI- AC0600W and GMI- AC2000 W) support dry-contact alarm outputs for fault and temperature alerts..
9. AC Sunshade Cover : Available upon request for additional protection against direct sunlight and rain.



GAMMA FEC CABINETS IP66 FLOOR STAND WITH AIR CONDITIONING & MONITORING INTERFACE

Part Number	Standard Description (H X W X D) mm	Cooling Capacity (W)
GMI-FEC-21U-88-2000AC	GMI Saudi Made, 21U 800×800 Field Equipment Cabinet (FEC), IP66 floor standing welded structure, galvanized steel, powder coated RAL 7035, with 2 pairs of 19 inch pillars, double skin with insulation, 100 mm base plinth, front & rear doors with 3-point locking handle, back door fitted with integrated 2000W cooling unit with monitoring interface.	2000 W Option(600 W)
GMI-FEC-26U-88-2000AC	GMI Saudi Made, 26U 800×800 Field Equipment Cabinet (FEC), IP66 floor standing welded structure, galvanized steel, powder coated RAL 7035, with 2 pairs of 19 inch pillars, double skin with insulation, 100 mm base plinth, front & rear doors with 3-point locking handle, back door fitted with integrated 2000W cooling unit with monitoring interface.	2000 W Option(600 W)
GMI-FEC-32U-88-2000AC	GMI Saudi Made, 32U 800×800 Field Equipment Cabinet (FEC), IP66 floor standing welded structure, galvanized steel, powder coated RAL 7035, with 2 pairs of 19 inch pillars, double skin with insulation, 100 mm base plinth, front & rear doors with 3-point locking handle, back door fitted with integrated 2000W cooling unit with monitoring interface.	2000 W Option(600 W)
GMI-FEC-42U-88-2000AC	GMI Saudi Made, 42U 800×800 Field Equipment Cabinet (FEC), IP66 floor standing welded structure, galvanized steel, powder coated RAL 7035, with 2 pairs of 19 inch pillars, double skin with insulation, 100 mm base plinth, front & rear doors with 3-point locking handle, back door fitted with integrated 2000W cooling unit with monitoring interface.	2000 W Option(600 W)
GMI-FEC-42U-810-2000AC	GMI Saudi Made, 42U 800×1000 Field Equipment Cabinet (FEC), IP66 floor standing welded structure, galvanized steel, powder coated RAL 7035, with 2 pairs of 19 inch pillars, double skin with insulation, 100 mm base plinth, front & rear doors with 3-point locking handle, back door fitted with integrated 2000W cooling unit with monitoring interface.	2000 W Option(600 W)

OTHER SIZES AVAILABLE ON REQUEST

Specifications and datasheets are subject to change without prior notice.



GAMMA FEC CABINETS IP66 FLOOR STAND WITH AIR CONDITIONING & MONITORING INTERFACE

Part Number	Standard Description (H X W X D) mm	Cooling Capacity (W)
GMI-FEC-32U-1358-2000AC	GMI Saudi Made, 32U 1350×800 Field Equipment Cabinet (FEC), IP66 floor standing welded structure, galvanized steel, powder coated RAL 7035, with 4 pairs of 19 inch pillars, double skin with insulation, 100 mm base plinth, front & rear double doors with 3-point locking handle, side fitted with integrated 2000W cooling unit with monitoring interface.	2000 W Option(600 W)
GMI-FEC-32U-1358-2002AC	GMI Saudi Made, 32U 1350×800 Field Equipment Cabinet (FEC), IP66 floor standing welded structure, galvanized steel, powder coated RAL 7035, with 4 pairs of 19 inch pillars, double skin with insulation, 100 mm base plinth, front & rear double doors with 3-point locking handle, side fitted with two integrated 2000W cooling unit with monitoring interface.	2000 W Option(600 W)
GMI-FEC-42U-1358-2000AC	GMI Saudi Made, 42U 1350×800 Field Equipment Cabinet (FEC), IP66 floor standing welded structure, galvanized steel, powder coated RAL 7035, with 4 pairs of 19 inch pillars, double skin with insulation, 100 mm base plinth, front & rear double doors with 3-point locking handle, side fitted with integrated 2000W cooling unit with monitoring interface.	2000 W Option(600 W)
GMI-FEC-42U-1358-2002AC	GMI Saudi Made, 42U 1350×800 Field Equipment Cabinet (FEC), IP66 floor standing welded structure, galvanized steel, powder coated RAL 7035, with 4 pairs of 19 inch pillars, double skin with insulation, 100 mm base plinth, front & rear double doors with 3-point locking handle, side fitted with two integrated 2000W cooling unit with monitoring interface.	2000 W Option(600 W)
GMI-FEC-42U-810-2002AC	GMI Saudi Made, 42U 800×1000 Field Equipment Cabinet (FEC), IP66 floor standing welded structure, galvanized steel, powder coated RAL 7035, with 2 pairs of 19 inch pillars, double skin with insulation, 100 mm base plinth, front & rear doors with 3-point locking handle, back door fitted with two integrated 2000W cooling unit with monitoring interface.	2000 W Option(600 W)

OTHER SIZES AVAILABLE ON REQUEST

Specifications and datasheets are subject to change without prior notice.



SAUDI
MADE



صناعة
سعودية

رؤية
2030
المملكة العربية السعودية
KINGDOM OF SAUDI ARABIA



AIR CONDITIONED OUTDOOR FEC CABINETS TECHNICAL DATA SHEET



شركة مصنع جاما للصناعات المعدنية
GAMMA FACTORY FOR METAL INDS.

MORE THAN **15** YEARS IN MANUFACTURING OF :

- Cabinets & Accessories
- IP... Outdoor Enclosures
- NEMA x Stainless Steel Enclosures
- Power Distribution Unit (PDU)



GAMMA FEC ENCLOSURE IP 66 WITH AC
PART NUMBER - GMI-FEC-21U-88-600AC

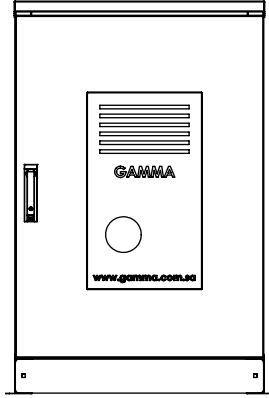

FRONT/BACK VIEW

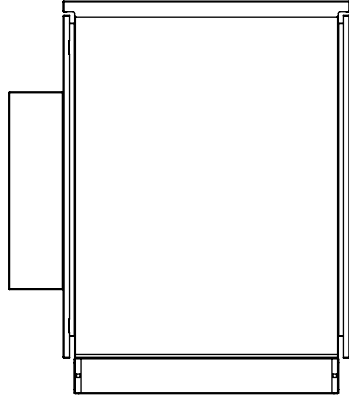

SIDE VIEW

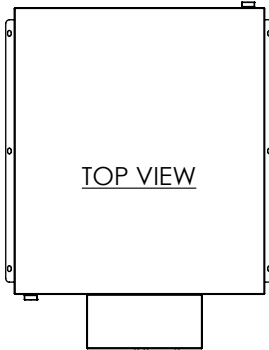

TOP VIEW

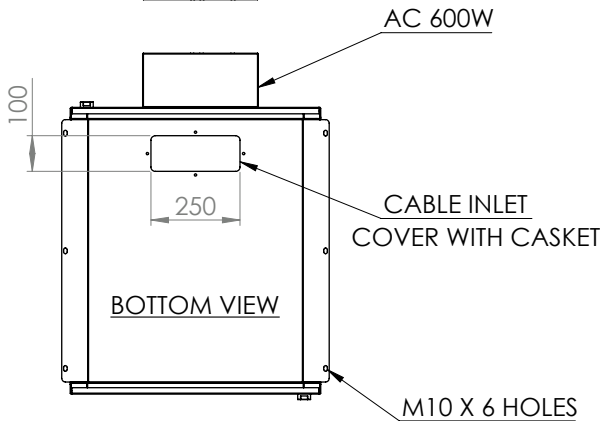

BOTTOM VIEW

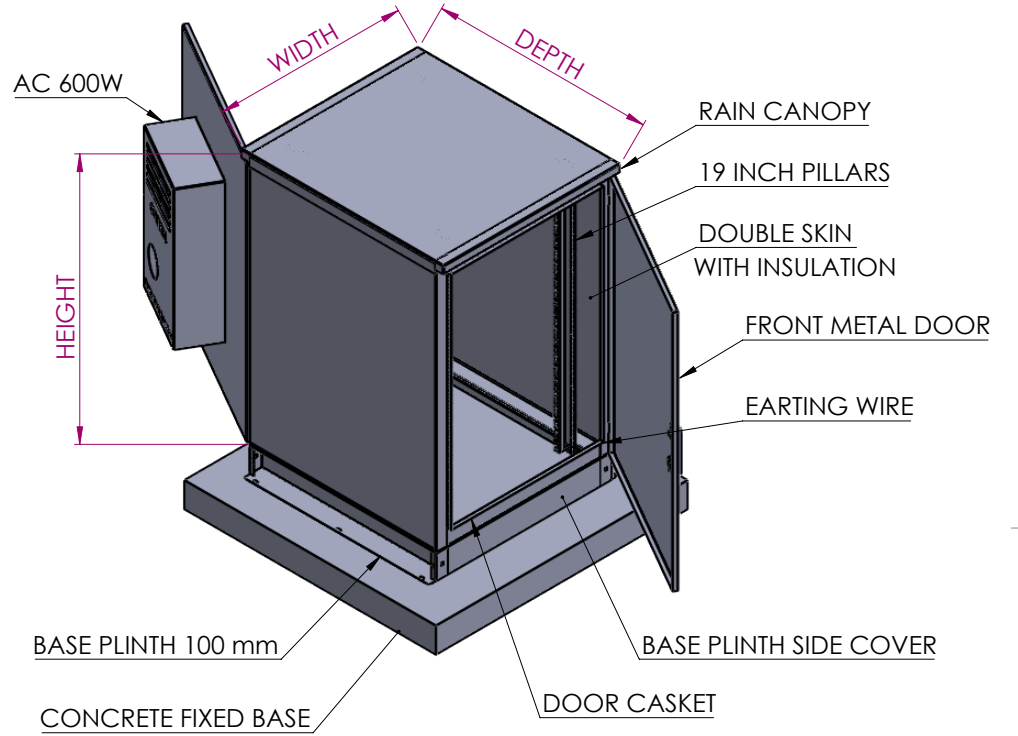

TECHNICAL DATA :-

ORDERING NO.	DESCRIPTION W(mm) X D(mm)	HEIGHT (H)
GMI-FEC-21U-88-600AC	800 X 800	1000

MATERIAL

- Galvanized Steel - Standard
- Stainless Steel 304 - Optional

TITLE : FEC CABINET ASSEMBLY WITH AC		
DRAWN	SUHAIL	
CHECKED	ENGR. JAMAL	
DATE	01/ 05 / 2026	REV : 00
SCALE	1:1	SHEET : 1/1
LOCATION : RIYADH, K.S.A		
GAMMA FOR METAL INDUSTRIES		
P.O. BOX. 390395 - RIYADH 11365,		
TEL: +966 1 2428536 / 2428537		
FAX : +966 1 2428538		
E-MAIL : info@gamma.com.sa		



ALL DIMENSIONS ARE IN mm

GAMMA FEC ENCLOSURE IP 66 WITH AC
PART NUMBER - GMI-FEC-21U-88-2000AC

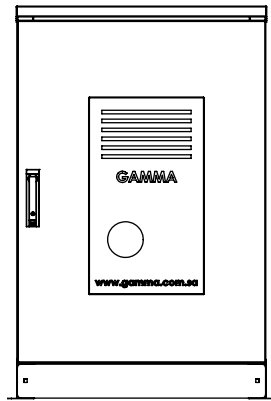

FRONT/BACK VIEW

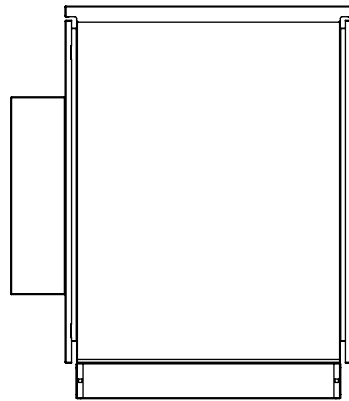

SIDE VIEW

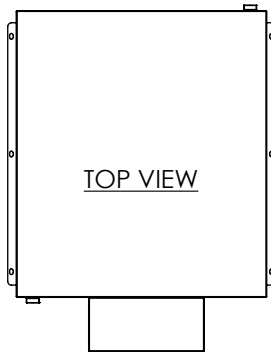

TOP VIEW

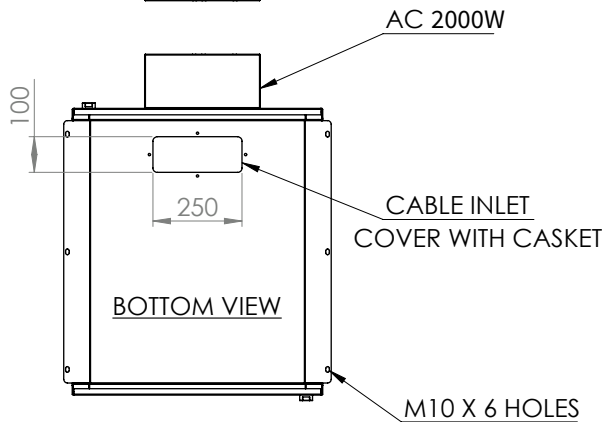

BOTTOM VIEW

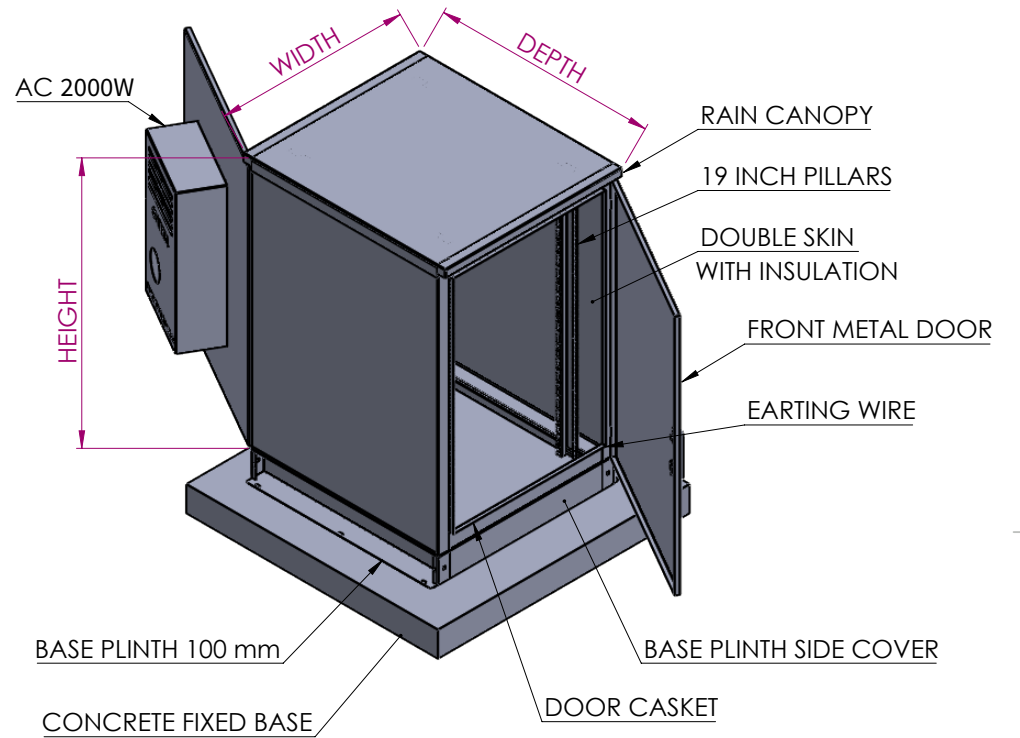

TECHNICAL DATA :-

ORDERING NO.	DESCRIPTION W(mm) X D(mm)	HEIGHT (H)
GMI-FEC-21U-88-2000AC	800 X 800	1000

MATERIAL

- Galvanized Steel - Standard
- Stainless Steel 304 - Optional

TITLE : FEC CABINET ASSEMBLY WITH AC		
DRAWN	SUHAIL	
CHECKED	ENGR. JAMAL	
DATE	01/ 05 / 2026	REV : 00
SCALE	1:1	SHEET : 1/1
LOCATION : RIYADH, K.S.A		
GAMMA FOR METAL INDUSTRIES		
P.O. BOX. 390395 - RIYADH 11365,		
TEL: +966 1 2428536 / 2428537		
FAX : +966 1 2428538		
E-MAIL : info@gamma.com.sa		



ALL DIMENSIONS ARE IN mm

GAMMA FEC ENCLOSURE IP 66 WITH AC
PART NUMBER - GMI-FEC-26U-88-2000AC

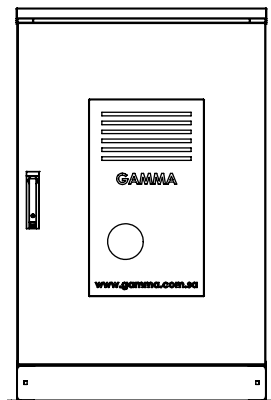

FRONT/BACK VIEW

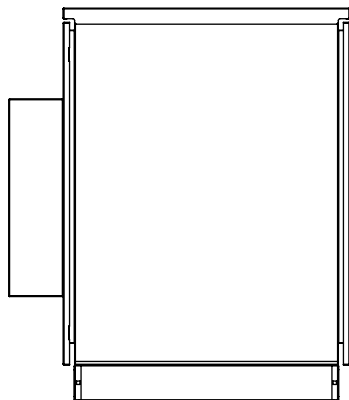

SIDE VIEW

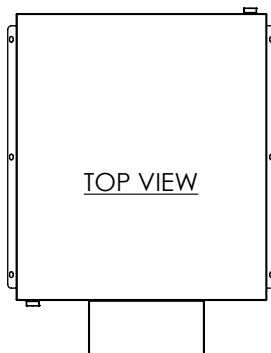

TOP VIEW

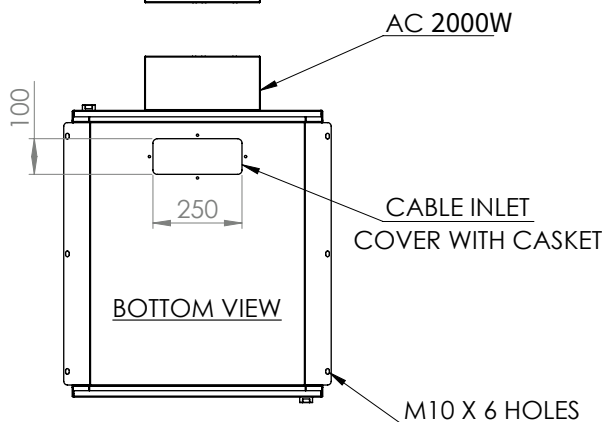

BOTTOM VIEW

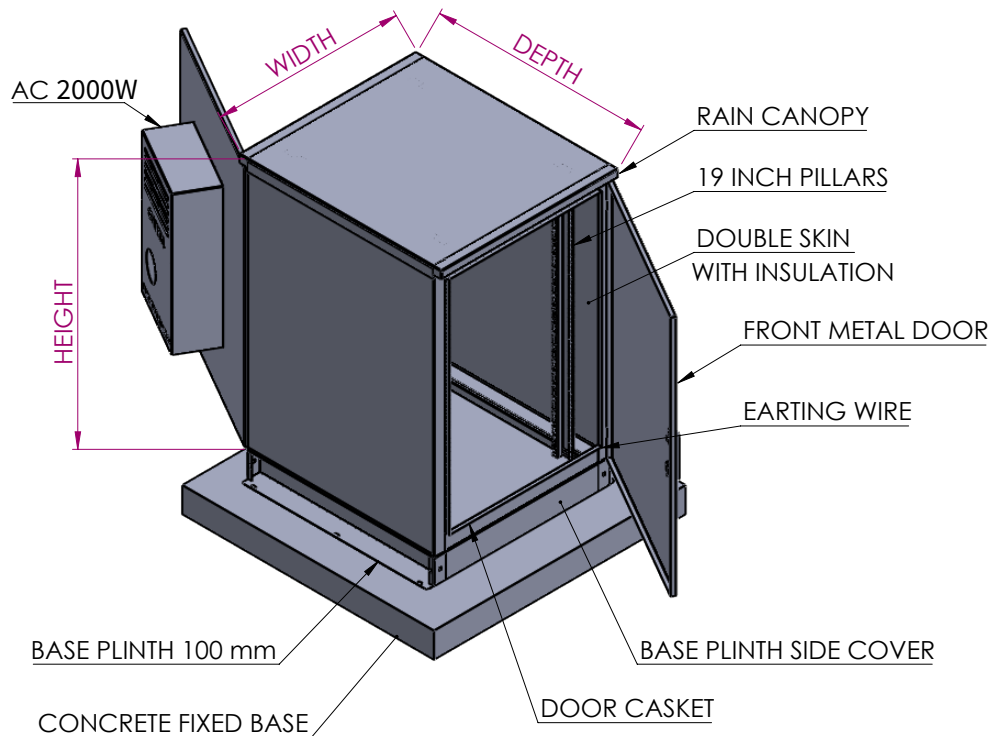

TECHNICAL DATA :-

ORDERING NO.	DESCRIPTION W(mm) X D(mm)	HEIGHT (H)
GMI-FEC-26U-88-2000AC	800 X 800	1195

MATERIAL

- Galvanized Steel - Standard
- Stainless Steel 304 - Optional

TITLE : FEC CABINET ASSEMBLY WITH AC		
DRAWN	SUHAIL	
CHECKED	ENGR. JAMAL	
DATE	01/ 05 / 2026	REV : 00
SCALE	1:1	SHEET : 1/1

LOCATION : RIYADH, K.S.A

GAMMA FOR METAL INDUSTRIES
P.O. BOX. 390395 - RIYADH 11365,
TEL: +966 1 2428536 / 2428537
FAX : +966 1 2428538
E-MAIL : info@gamma.com.sa



ALL DIMENSIONS ARE IN mm

GAMMA FEC ENCLOSURE IP 66 WITH AC
PART NUMBER - GMI-FEC-32U-88-2000AC



FRONT/BACK VIEW

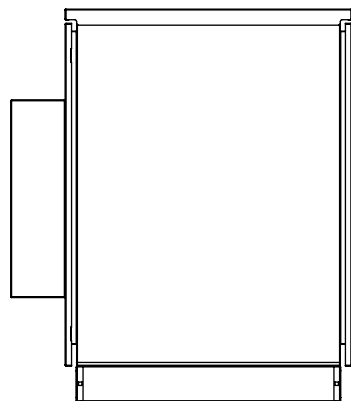

SIDE VIEW

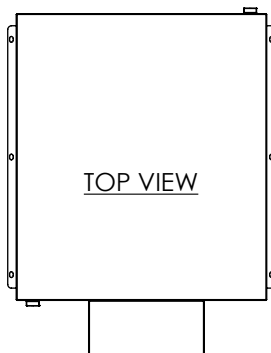

TOP VIEW

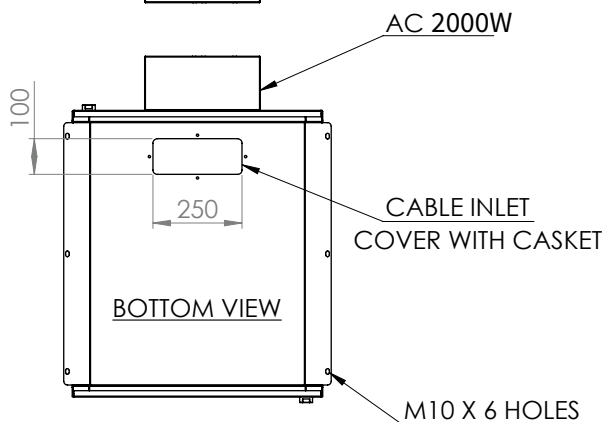

BOTTOM VIEW

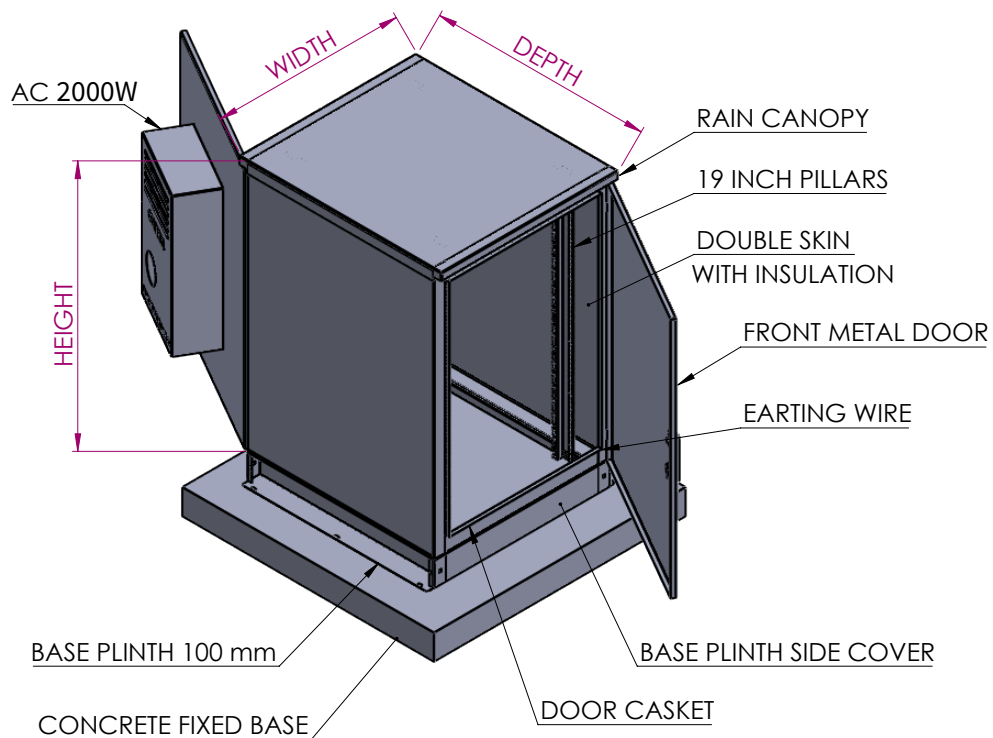

TECHNICAL DATA :-

ORDERING NO.	DESCRIPTION W(mm) X D(mm)	HEIGHT (H)
GMI-FEC-32U-88-2000AC	800 X 800	1500

MATERIAL

- Galvanized Steel - Standard
- Stainless Steel 304 - Optional

TITLE : FEC CABINET ASSEMBLY WITH AC		
DRAWN	SUHAIL	
CHECKED	ENGR. JAMAL	
DATE	01/ 05 / 2026	REV : 00
SCALE	1:1	SHEET : 1/1

LOCATION : RIYADH, K.S.A

GAMMA FOR METAL INDUSTRIES
P.O. BOX. 390395 - RIYADH 11365,
TEL.: +966 1 2428536 / 2428537
FAX : +966 1 2428538
E-MAIL : info@gamma.com.sa



ALL DIMENSIONS ARE IN mm

GAMMA FEC ENCLOSURE IP 66 WITH AC
PART NUMBER - GMI-FEC-42U-88-2000AC

ALL DIMENSIONS ARE IN mm

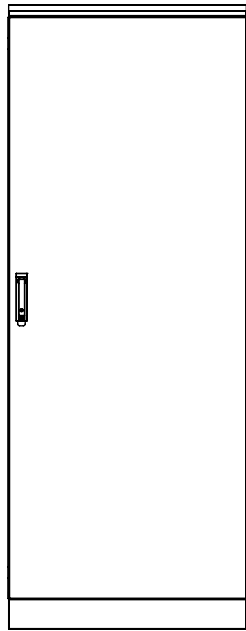

FRONT VIEW

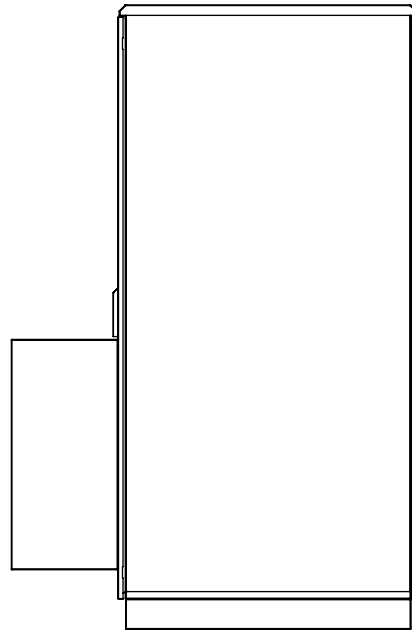

SIDE VIEW

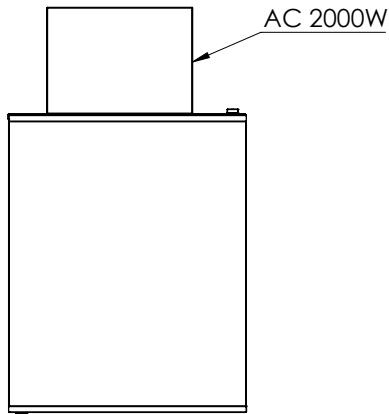

TOP VIEW

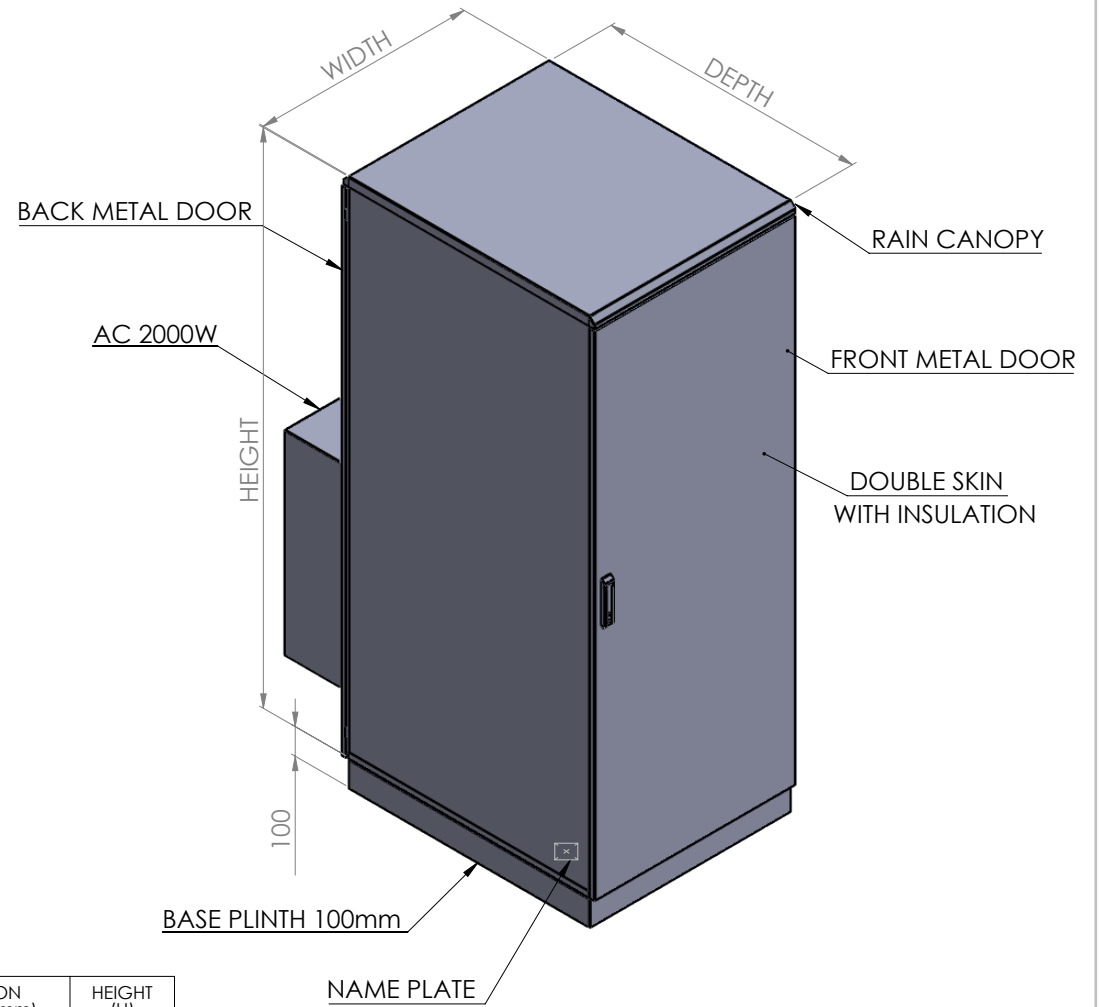

TECHNICAL DATA :-

ORDERING NO.	DESCRIPTION W(mm) X D(mm)	HEIGHT (H)
GMI-FEC-42U-88-2000AC	800 X 800	2000

MATERIAL

- Galvanized Steel - Standard
- Stainless Steel 304 - Optional

ALL DIMENSIONS ARE IN mm

TITLE :- OUTDOOR CABINET ASSEMBLY WITH AC		
DRAWN	SUHAIL	
CHECKED	ENGR. JAMAL	
DATE	01 / 05 / 2026	REV : 00
SCALE	1:1	SHEET : 1/1

LOCATION : RIYADH, K.S.A

GAMMA FOR METAL INDUSTRIES
 P.O. BOX. 390395 - RIYADH 11365,
 TEL.: +966 1 2428536 / 2428537
 FAX : +966 1 2428538
 E-MAIL : info@gamma.com.sa



GAMMA FEC ENCLOSURE IP 66 WITH AC
PART NUMBER - GMI-FEC-42U-810-2000AC

ALL DIMENSIONS ARE IN mm

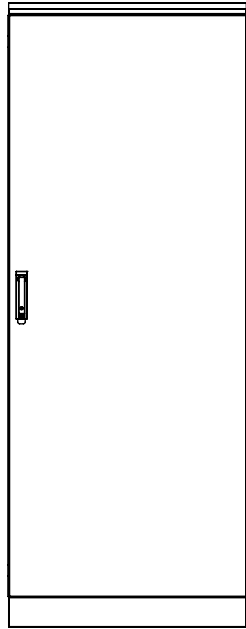

FRONT VIEW

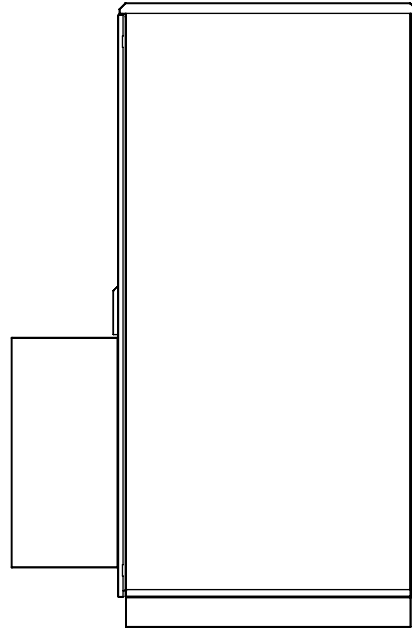

SIDE VIEW

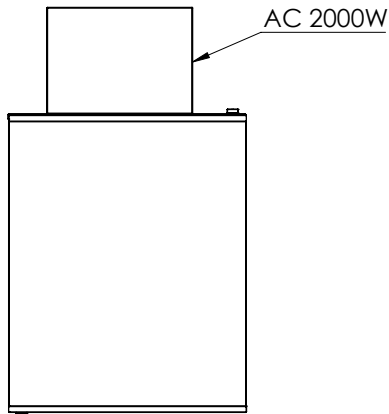

TOP VIEW

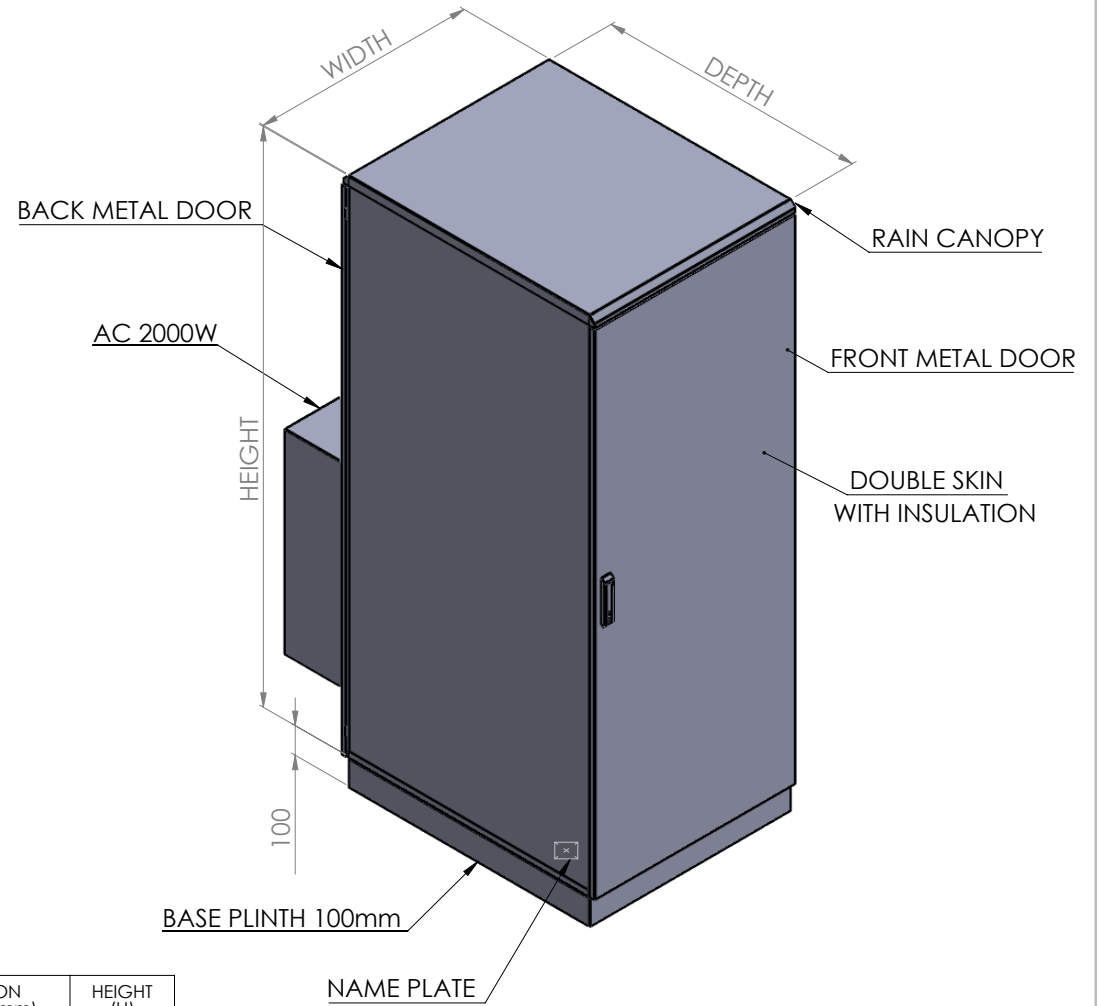

TECHNICAL DATA :-

ORDERING NO.	DESCRIPTION W(mm) X D(mm)	HEIGHT (H)
GMI-FEC-42U-810-2000AC	800 X 1000	2000

MATERIAL

- Galvanized Steel - Standard
- Stainless Steel 304 - Optional

ALL DIMENSIONS ARE IN mm

TITLE :- OUTDOOR CABINET ASSEMBLY WITH AC		
DRAWN	SUHAIL	
CHECKED	ENGR. JAMAL	
DATE	01 / 05 / 2026	REV : 00
SCALE	1:1	SHEET : 1/1

LOCATION : RIYADH, K.S.A

GAMMA FOR METAL INDUSTRIES
 P.O. BOX. 390395 - RIYADH 11365,
 TEL.: +966 1 2428536 / 2428537
 FAX : +966 1 2428538
 E-MAIL : info@gamma.com.sa



GAMMA FEC ENCLOSURE IP 66 WITH AC
PART NUMBER - GMI-FEC-32U-1358-2000AC

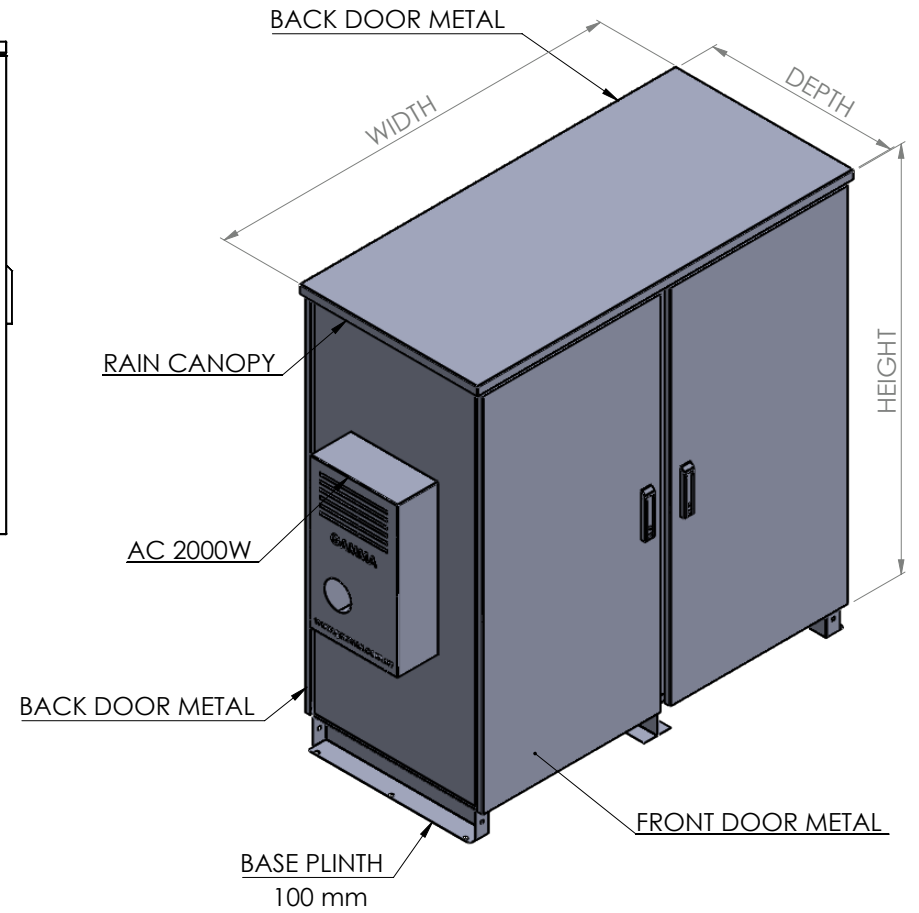
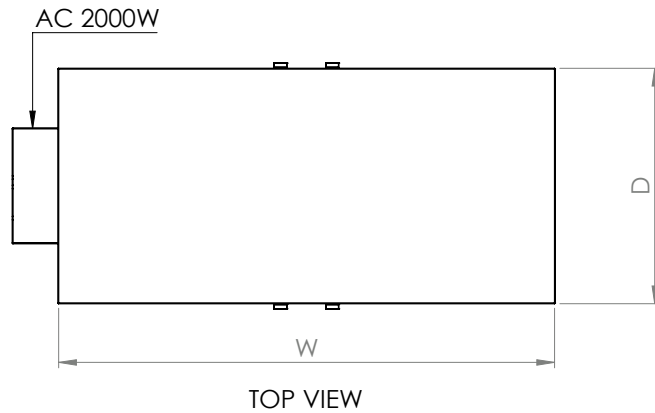
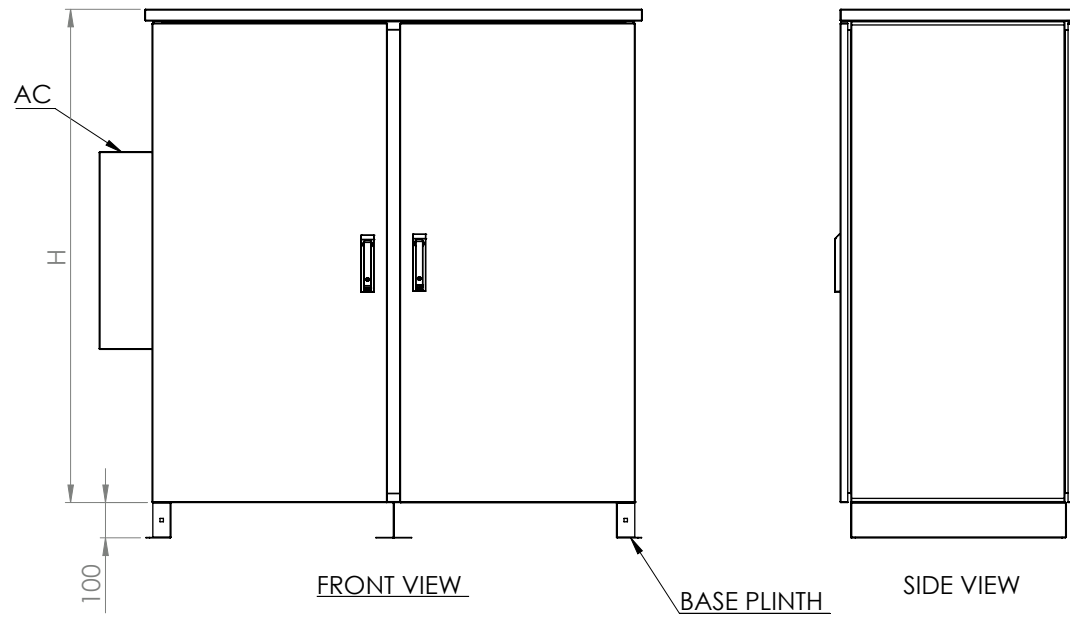

TECHNICAL DATA :-

ORDERING NO.	DESCRIPTION W(mm) X D(mm)	HEIGHT (H)
GMI-FEC-32U-1358-2000AC	1350 X 800	1500

TITLE :- AC OUTDOOR CABINET ASSEMBLY

DRAWN	SUHAIL	
CHECKED	ENGR. JAMAL	
DATE	01 / 05 / 2026	REV : 00
SCALE	1:1	SHEET : 1/1

LOCATION : RIYADH, K.S.A

GAMMA FOR METAL INDUSTRIES

P.O. BOX. 390395 - RIYADH 11365,
 TEL.: +966 1 2428536 / 2428537
 FAX : +966 1 2428538
 E-MAIL : info@gamma.com.sa



ALL DIMENSIONS ARE IN mm

GAMMA FEC ENCLOSURE IP 66 WITH AC
PART NUMBER - GMI-FEC-42U-1358-2000AC

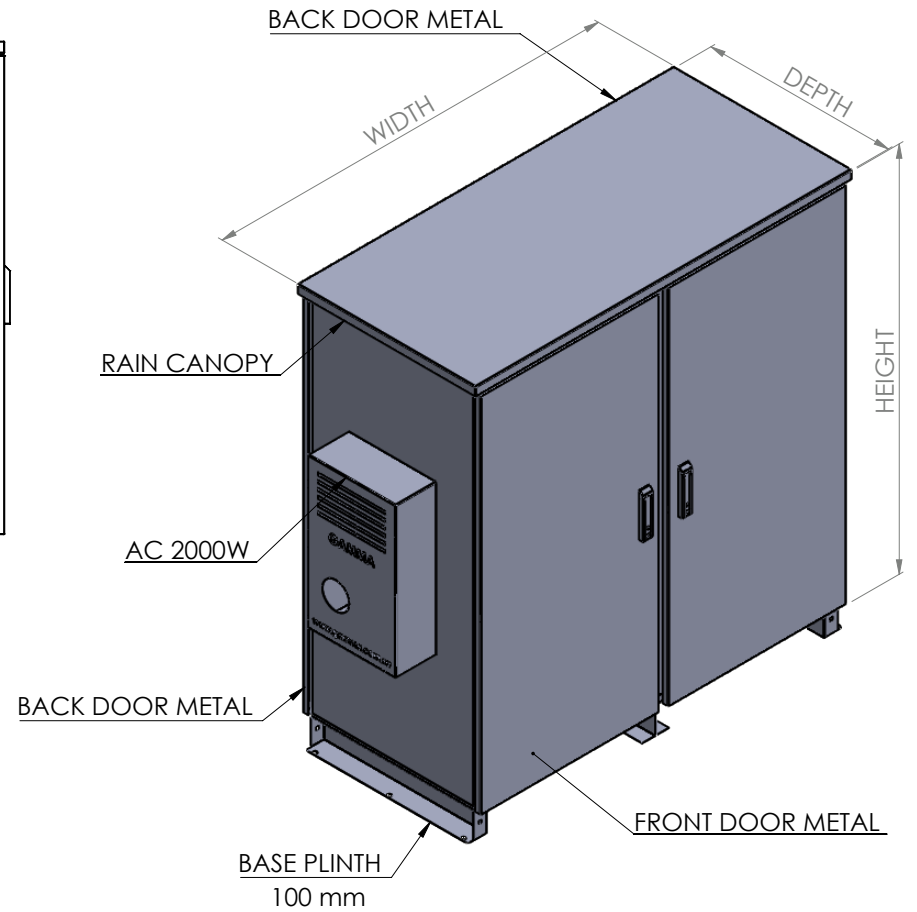
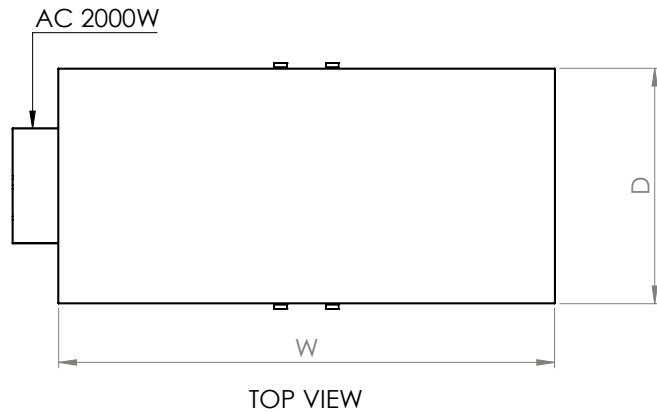
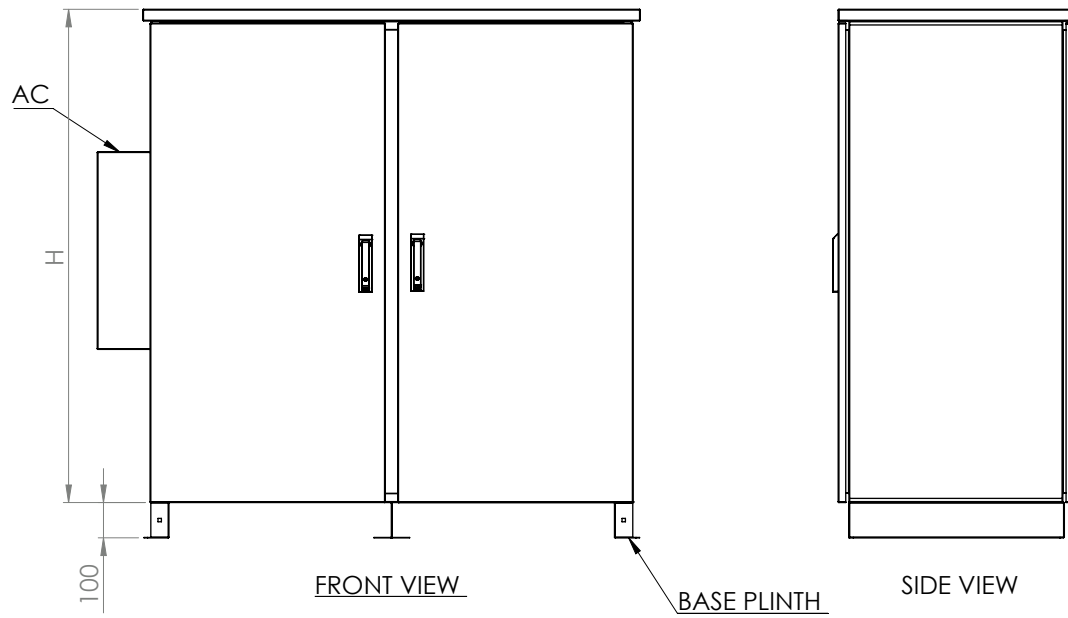

TECHNICAL DATA :-

ORDERING NO.	DESCRIPTION W(mm) X D(mm)	HEIGHT (H)
GMI-FEC-42U-1358-2000AC	1350 X 800	2000

TITLE :- AC OUTDOOR CABINET ASSEMBLY		
DRAWN	SUHAIL	
CHECKED	ENGR. JAMAL	
DATE	01 / 05 / 2026	REV : 00
SCALE	1:1	SHEET : 1/1

LOCATION : RIYADH, K.S.A

GAMMA FOR METAL INDUSTRIES
P.O. BOX. 390395 - RIYADH 11365,
TEL.: +966 1 2428536 / 2428537
FAX : +966 1 2428538
E-MAIL : info@gamma.com.sa



ALL DIMENSIONS ARE IN mm

GAMMA FEC ENCLOSURE IP 66 WITH 2X AC
PART NUMBER - GMI-FEC-42U-810-2002AC

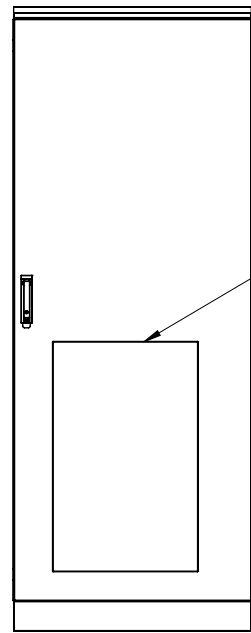

FRONT VIEW

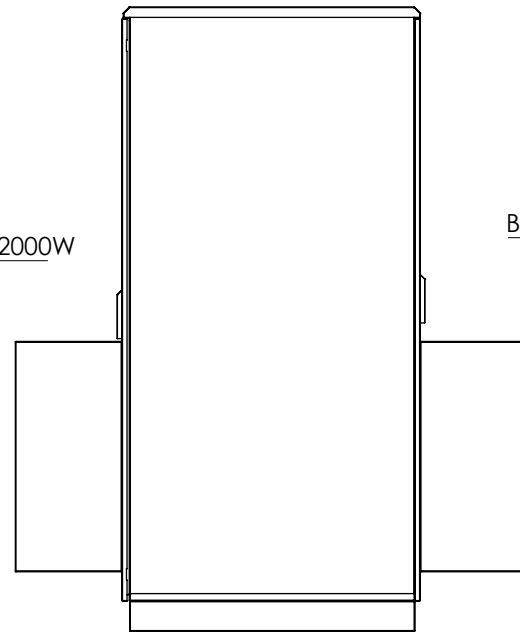

SIDE VIEW

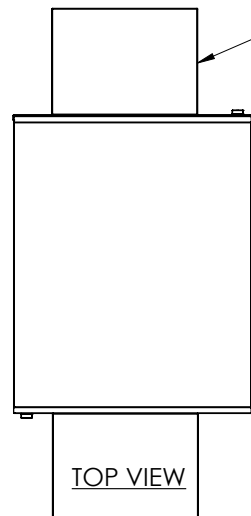

TOP VIEW

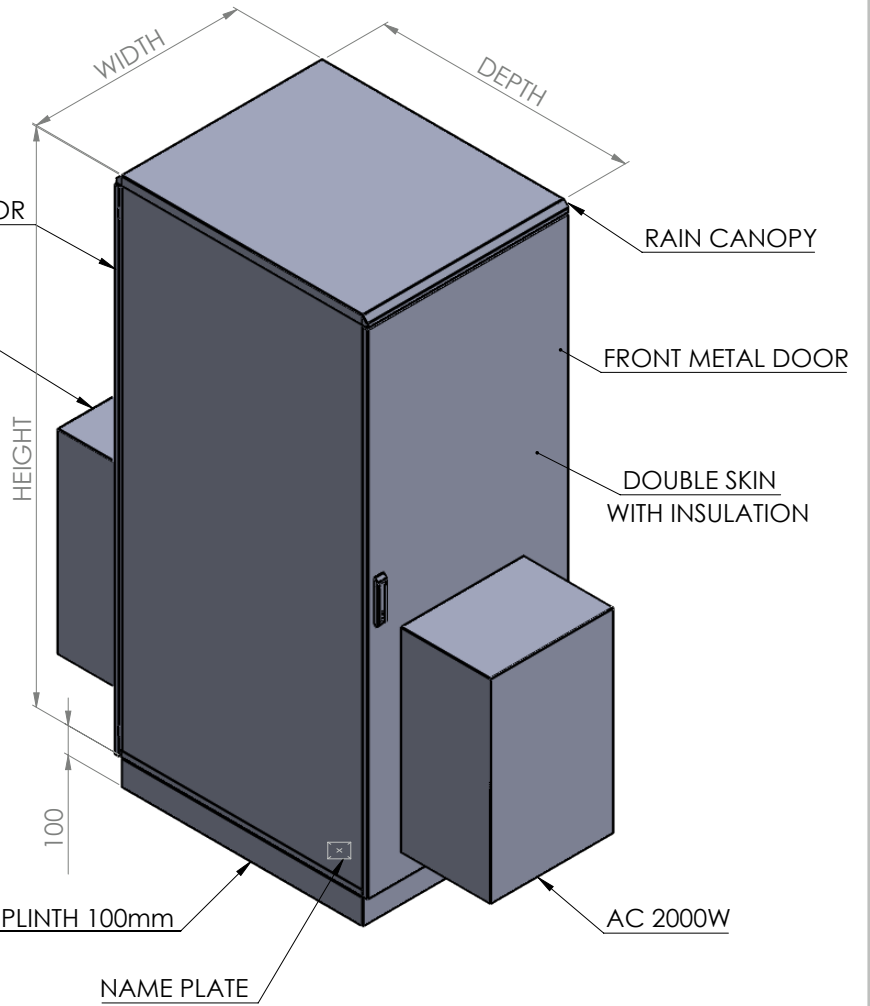

TECHNICAL DATA :-

ORDERING NO.	DESCRIPTION W(mm) X D(mm)	HEIGHT (H)
GMI-FEC-42U-810-2002AC	800 X 1000	2000

MATERIAL

- Galvanized Steel - Standard
- Stainless Steel 304 - Optional

ALL DIMENSIONS ARE IN mm

TITLE :- OUTDOOR CABINET ASSEMBLY WITH AC		
DRAWN	SUHAIL	
CHECKED	ENGR. JAMAL	
DATE	01 / 05 / 2026	REV : 00
SCALE	1:1	SHEET : 1/1

LOCATION : RIYADH, K.S.A

GAMMA FOR METAL INDUSTRIES
 P.O. BOX. 390395 - RIYADH 11365,
 TEL.: +966 1 2428536 / 2428537
 FAX : +966 1 2428538
 E-MAIL : info@gamma.com.sa



**GAMMA FEC ENCLOSURE IP 66 WITH 2X AC
PART NUMBER - GMI-FEC-32U-1358-2002AC**

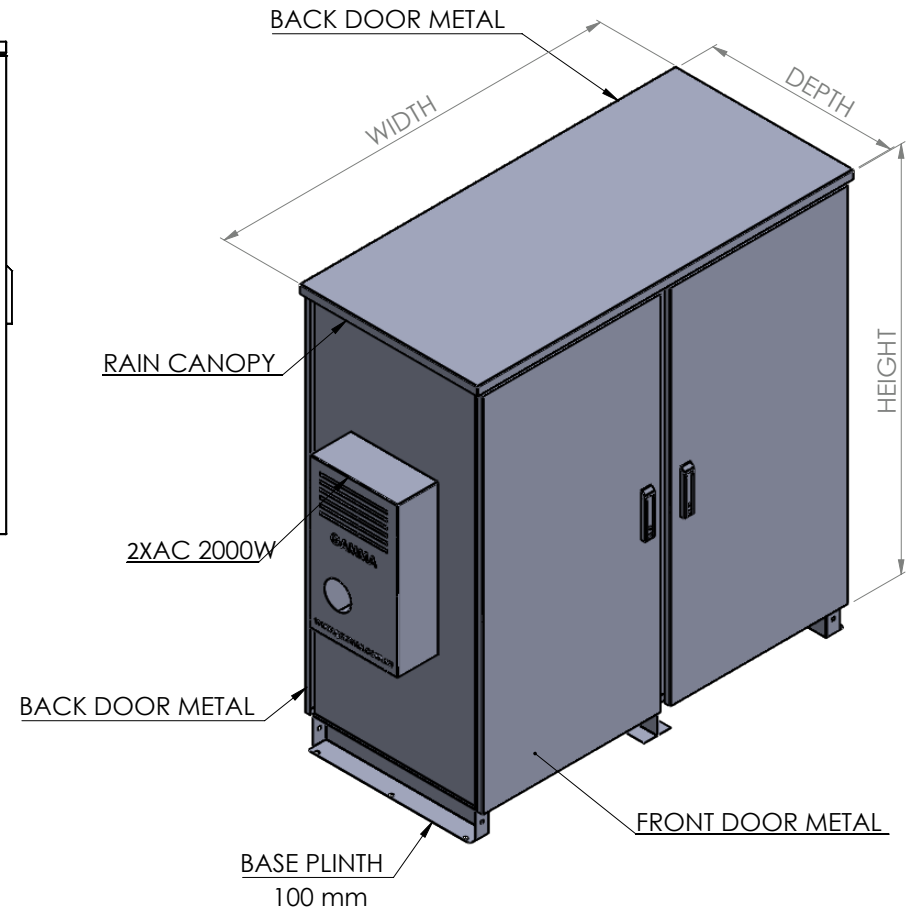
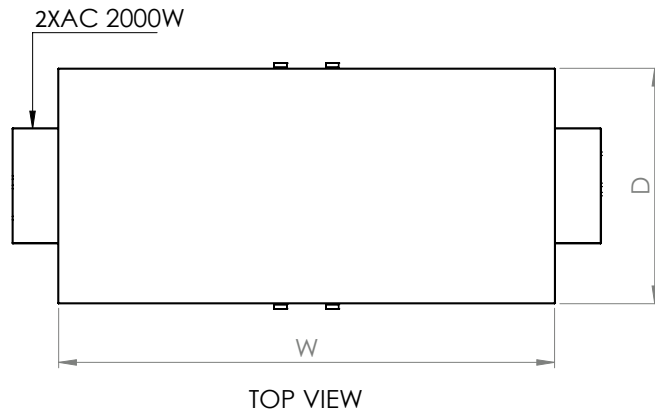
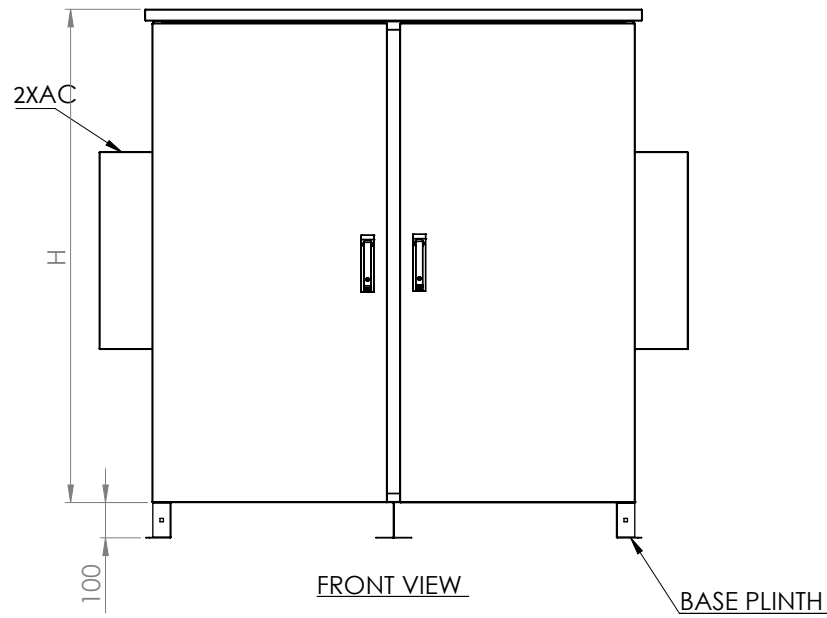

TECHNICAL DATA :-

ORDERING NO.	DESCRIPTION W(mm) X D(mm)	HEIGHT (H)
GMI-FEC-32U-1358-2002AC	1350 X 800	1500

TITLE :- AC OUTDOOR CABINET ASSEMBLY

DRAWN	SUHAIL	
CHECKED	ENGR. JAMAL	
DATE	01 /05 / 2026	REV : 00
SCALE	1:1	SHEET : 1/1

LOCATION : RIYADH, K.S.A

GAMMA FOR METAL INDUSTRIES

P.O. BOX. 390395 - RIYADH 11365,
TEL.: +966 1 2428536 / 2428537
FAX : +966 1 2428538
E-MAIL : info@gamma.com.sa



ALL DIMENSIONS ARE IN mm

**GAMMA FEC ENCLOSURE IP 66 WITH 2X AC
PART NUMBER - GMI-FEC-42U-1358-2002AC**

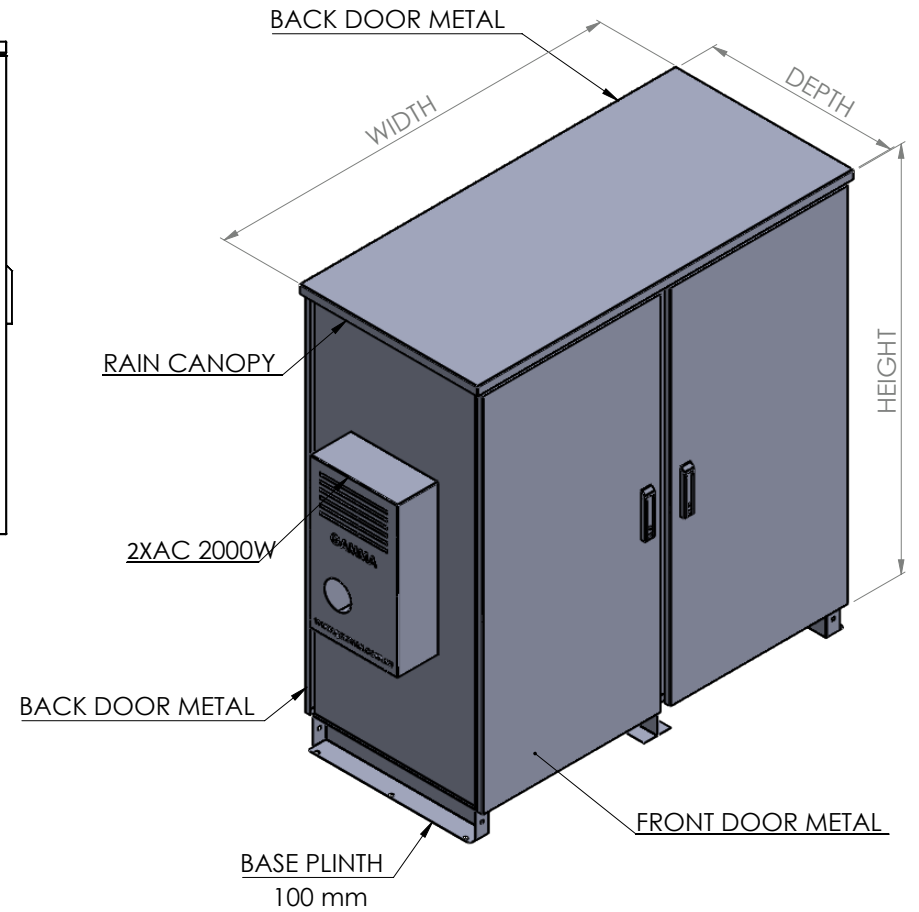
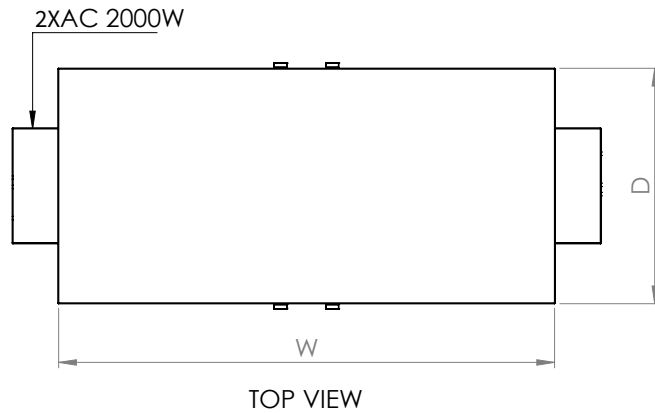
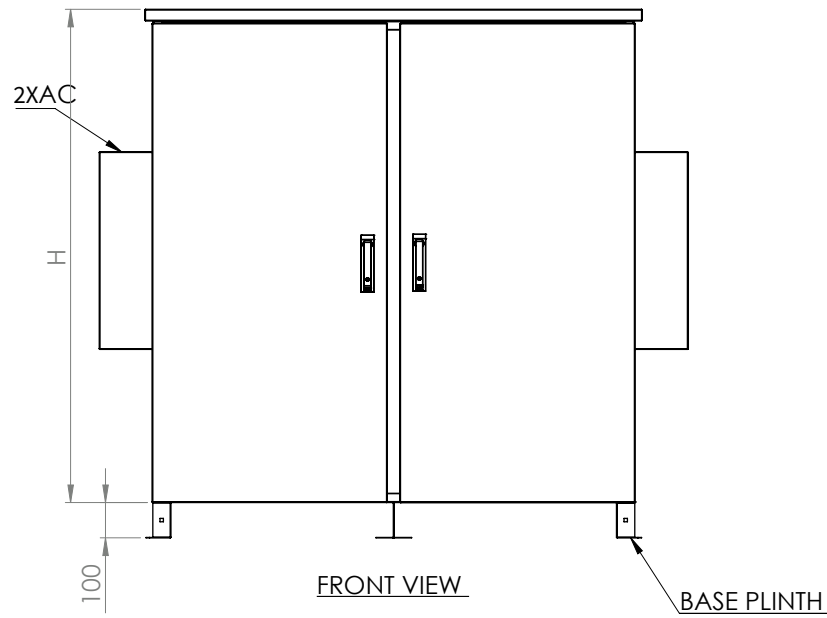

TECHNICAL DATA :-

ORDERING NO.	DESCRIPTION W(mm) X D(mm)	HEIGHT (H)
GMI-FEC-42U-1358-2002AC	1350 X 800	2000

TITLE :- AC OUTDOOR CABINET ASSEMBLY

DRAWN	SUHAIL	
CHECKED	ENGR. JAMAL	
DATE	25 / 06 / 2026	REV : 00
SCALE	1:1	SHEET : 1/1

LOCATION : RIYADH, K.S.A

GAMMA FOR METAL INDUSTRIES

P.O. BOX. 390395 - RIYADH 11365,
TEL.: +966 1 2428536 / 2428537
FAX : +966 1 2428538
E-MAIL : info@gamma.com.sa



ALL DIMENSIONS ARE IN mm

GAMMA FACTORY FOR METAL INDUSTRIES

2000W AC AIR CONDITIONER Datasheet

Model No : GMI-AC2000

PRODUCT INTRODUCTION

- Closed-loop, compact, mono-block design.
- Input voltage: 220V \pm 15% AC, 50/60Hz.
- Operational temperature: $-15^{\circ}\text{C} \sim 55^{\circ}\text{C}$.
- Refrigerant: R134a.

- Model No : GMI-AC2000

FEATURES AND BENEFITS

- Door / Side Mounted .
- Low-noise external fan.
- Auto-recovery with multi-protection functions.
- High-efficiency compressor.
- Interface for configuration & monitoring.
- Dry-contact alarm outputs (fault & temperature).
- RS485 communication for remote monitoring.
- Sun Shade Cover . (option)

TECHNICAL DATA

- Input Voltage: 220V \pm 15% AC, 50/60Hz
- Cooling Capacity : 2000W
- Power Consumption : 850W
- Rated Current: 3.9A
- Operating Temperature: -15°C to 55°C
- Net Weight: 34 kg
- Dimensions (HxWxD): 750x450x200 mm
- Protection Level: IP55
- Noise Level: 60-65 dB(A)
- 1 Years Warranty
- Color: RAL7035

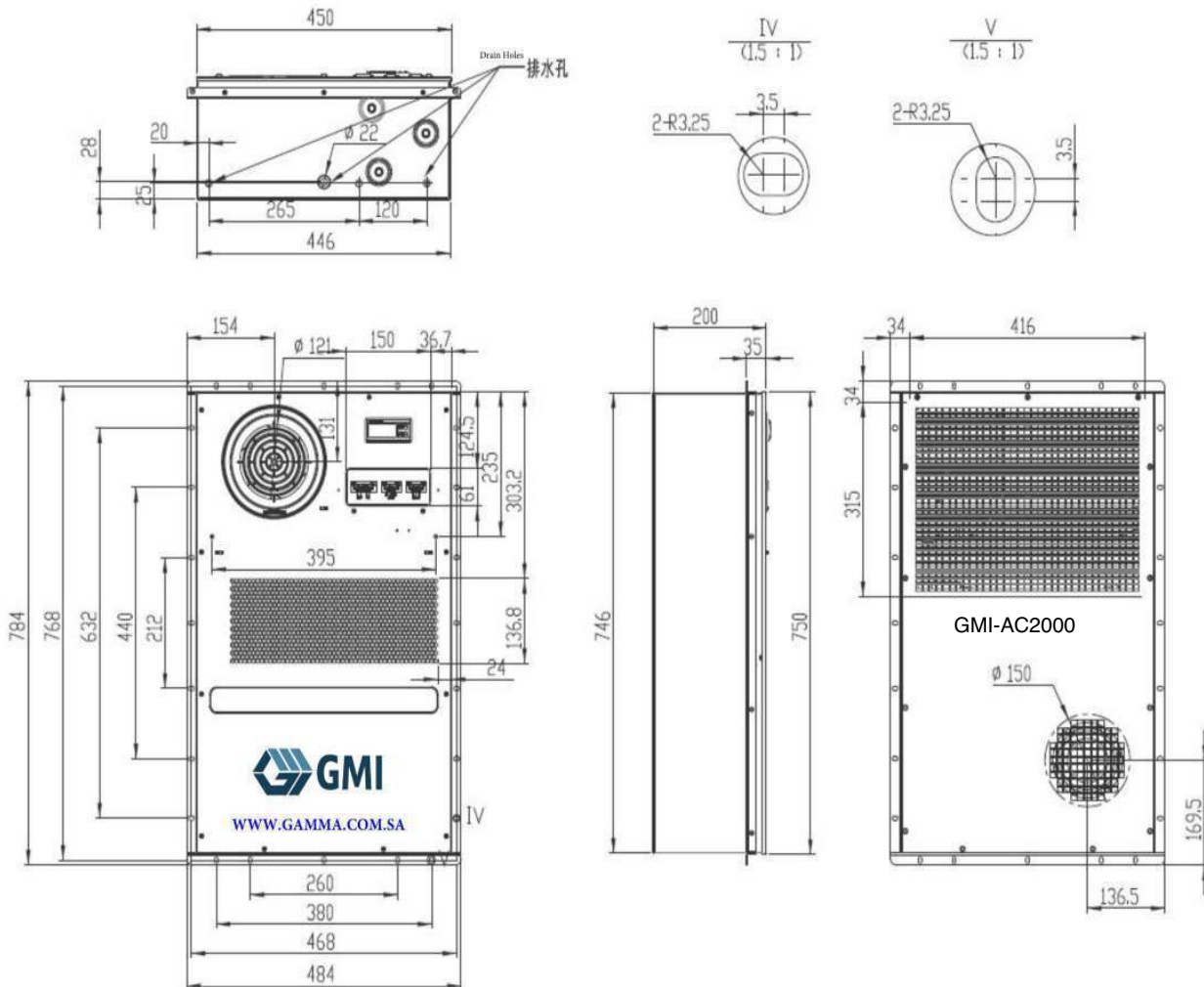

Maintenance Recommendation:

Periodic inspection and preventive maintenance are recommended for optimal cooling performance.

Specifications and datasheets are subject to change without prior notice.

GAMMA FACTORY FOR METAL INDUSTRIES

600W AC AIR CONDITIONER Datasheet

Model No : GMI-AC0600

PRODUCT INTRODUCTION

- Closed-loop, compact, mono-block design.
- Input voltage: 220V \pm 15% AC, 50/60Hz.
- Operational temperature: $-15^{\circ}\text{C} \sim 55^{\circ}\text{C}$.
- Refrigerant: R134a.
- Model No : GMI-AC0600

FEATURES AND BENEFITS

- Door / Side Mounted .
- Low-noise external fan.
- Auto-recovery with multi-protection functions.
- High-efficiency compressor.
- Interface for configuration & monitoring.
- Dry-contact alarm outputs (fault & temperature).
- RS485 communication for remote monitoring.
- Sun Shade Cover (option)

TECHNICAL DATA

- Input Voltage: 220V \pm 15% AC, 50/60Hz
- Cooling Capacity : 600W
- Power Consumption : 255W
- Rated Current: 1.2 A
- Operating Temperature: -15°C to 55°C
- Net Weight: 16 kg
- Dimensions (HxWxD): 550x320x170 mm
- Protection Level: IP55
- Noise Level: 57-62 dB(A)
- 1 Year Warranty
- Color: RAL7035

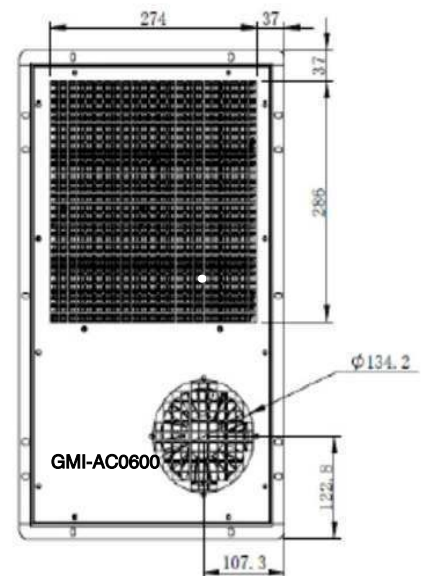
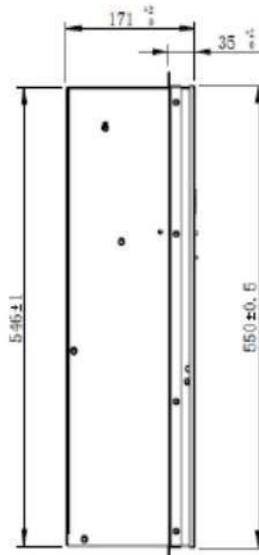
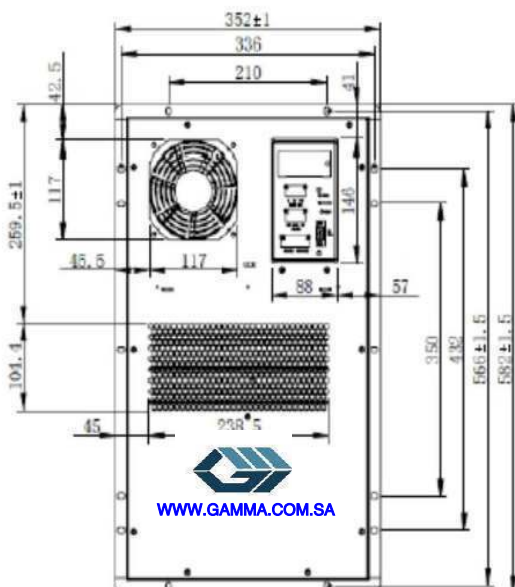
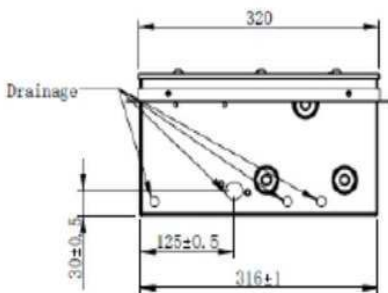

Maintenance Recommendation:

Periodic inspection and preventive maintenance are recommended for optimal cooling performance. Specifications and datasheets are subject to change without prior notice.

GAMMA BATTERY CLOSE CABINETS – CUSTOM MADE DESIGN

◆ Standard Dimensions :

Height : UP to 2200 mm

Width : Sizes available Based on customer Number of Batteries and size

◆ Standard Colour :

RAL 9005
BLACK



RAL 7035
Light Gray



Other colours available
on request



◆ Complying with International Standards:

- ISO 9001-2015
- ISO 14001:2015
- IP20 Protected – Other IP rated Available on Request
- MADE IN KSA



◆ GAMMA BATTERY CLOSE CABINETS – CUSTOM MADE DESIGN SECTION

➤ TECHNICAL DATA:

- Gamma Battery close - Custom Made Design
- Heavy Duty Frame and Shelves structure
- Screw Type Assembly
- Static Load up to 1800 kg -
- Shelf static load up to 300 Kg
- Removable Side Panels with perforated for air ventilation
- Removable Back and Front Door with ventilation
- 100 mm Legs
- Powder coated RAL 9005 Black or RAL 7035 Light Gray
- Cable inlet from all shelves
- Custom made design as per battery size and Quantity
- **Made in Saudi Arabia**
- IP 20 protected , other IP rated available on request



GAMMA BATTERY CLOSE CABINETS –CUSTOM DESIGN

Model 1: Dimensions: 700 (width) x 900 (depth) x 2000 (height).
 NOTE :- BATTERY SIZE 261 X 168 X 224.5
 1 SHELF - 8 PCS BATTERY
 5 SHELF - 40 PCS BATTERY

Model 2: Dimensions: 700 (width) x 700 (depth) x 1600 (height).
 NOTE :- BATTERY SIZE 166 X 175 X 125
 1 SHELF - 9 PCS BATTERY
 4 SHELF - 36 PCS BATTERY

Model 3: Dimensions: 700 (width) x 700 (depth) x 1600 (height).
 NOTE :- BATTERY SIZE 261 X 168 X 223
 1 SHELF - 6 PCS BATTERY
 4 SHELF - 24 PCS BATTERY

Model 4: Dimensions: 800 (width) x 800 (depth) x 600 (height).
 NOTE :- 350 X 168 X 225
 1 SHELF - 3 PCS BATTERY

ALL DIMENSIONS ARE IN MM

TITLE - BATTERY RACK ASSEMBLY			
DRAWN	SUHAL		
CHECKED	ENGR. JAMAL		
DATE	16 / 11 / 2020	REV	: 00
SCALE	1:1	SHEET	: 1/1
LOCATION:- RYADH, K.S.A			
GAMMA FOR METAL INDUSTRIES			
P.O. BOX 390395 - RYADH 11365			
TEL. : +966 1 2428536 / 2428537			
FAX : +966 1 2428538			
E-MAIL : info@gamma.com.sa			

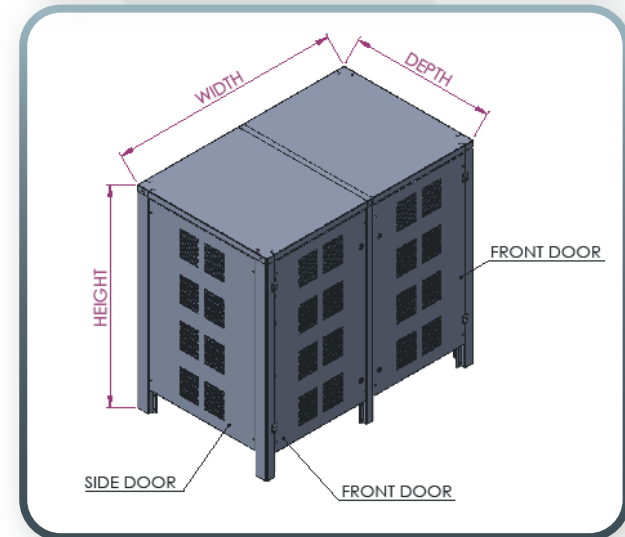
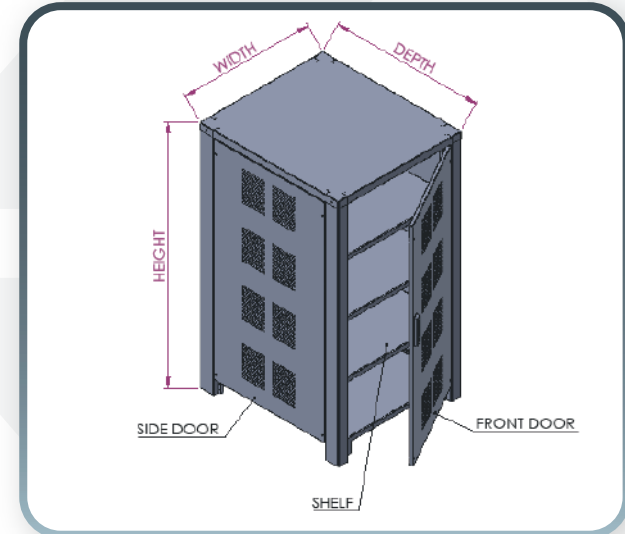

GAMMA CABINETS MANUFACTURED ACCORDING
EIA-310 E , ETSI SPECIFICATIONS
 Gamma Data Cabinets Fit all 19" Equipments

GAMMA NET AXIAL FAN DATA SHEET

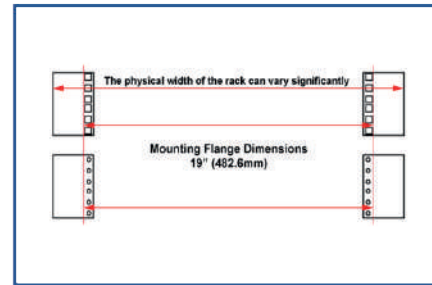
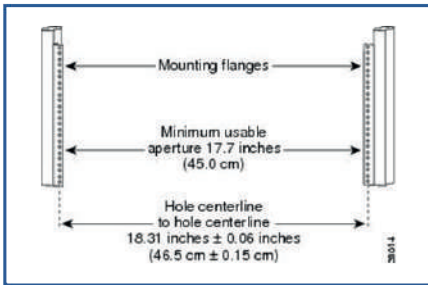

GAMMA Ventilation Fan Calculation:

GAMMA Ventilation Calculation as below clarifications:

- a. 1 KW = 3,413.0 BTU/HR
- b. 3.5 KW = 11,945.5 BTU
- c. 12,000 BTU = 1 TON of air conditioning
- d. 11,942 BTU = 0.9952 TON of air-conditioning
- e. 1 Ton of Air Conditional = 400 CFM
- f. 3.5 KW = ~398.1 CFM
- g. 1 FAN = 105 CFM, 4 FANS = 420 CFM ~ 3.69 KW heat Dissipation

4 Fans will be enough for 3.5 KW heat.

GAMMA FACTORY FOR METAL INDUSTRIES
 GAMMA AXIAL FAN

FAN TECHNICAL DATA
 FAN SIZE : 119 X 119 X 38 mm
 VOLTAGE : 220 VOLTS
 AIR VOLUME : 105 CFM
 FREQUENCY : 60 HZ
 CURRENT : 0.14 AMP

Ventilation Calculation:
 a. 1 KW = 3,413.0 BTU/HR
 b. 3.5 KW = 11,945.5 BTU
 c. 12,000 BTU = 1 TON of air conditioning
 d. 11,942 BTU = 0.9952 TON of air-conditioning
 e. 1 Ton of Air Conditional = 400 CFM
 f. 3.5 KW = ~398.1 CFM
 g. 1 FAN = 105 CFM ,
 4 FANS = 420 CFM ~ 3.69 KW heat Dissipation

REV: 01 / 01 / 2016
 SCALE: 1:1
 DRAWN: HANAD A.S.A.
 CHECKED: INGI HANAD
 DATE: 01 / 01 / 2016
 DWG: 119
 SHEET: 1/1

GAMMA FOR METAL INDUSTRIES
 P.O. BOX 30201 - RIYADH 11511
 TEL: +966 11 50000000
 FAX: +966 11 50000000
 EMAIL: info@gamma.com.sa

GAMMA NET RACK CABINETS OPTIONS

Part Number	Description
GMC-SDP-F	Single Door Perforated Front
GMC-SDP-B	Single Door Perforated back
GMC-DDP-F	Double Door Perforated Front 800
GMC-DDP-B	Double Door Perforated Back 800
GMC-DDP-F-60	Double Door Perforated Front 600
GMC-DDP-B-60	Double Door Perforated Back 600
GMC-VCM	Vertical Cable Management for 800 W
GMC-EBB	Earthing Bus Bar – 19" rack mounted
GMC-TH-M	Thermostat for Fans -Mechanical
GMC-EK	Earthing Kit – 10 pcs/set
GMC-HCO	Horizontal Cable Organizer – 19" Mount
GMC-PS	Perforated Side Doors
GMC-GN	Gauge Nut – 20 pcs/set
GMC-FR	Fixed Shelves
GMC-SLS	Sliding Shelf
GMC-7035	Colour Light Gray RAL 7035
GMC-CT	Vertical Cable Tray (2 pcs)
GMC-BP-1U	1U Blank Panel
GMC-BP-2U	2U Blank Panel
GMC-GP	Gland Plate for base covering
GMC-PDU-6W-UK13A	PDU 6 Way UK type 13 Amps
GMC-PDU-UK-6W-16A	PDU 6 Way UK type 16 Amps
GMC-C13-C19-16A	Vertical PDU C13 X 20 , C19 X 4 , 16 A
GMC-C13-C19-32A	Vertical PDU C13 X 20 , C19 X 4 , 32 A

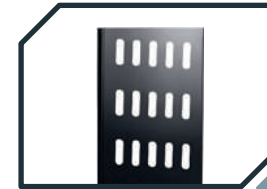
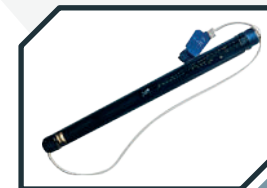
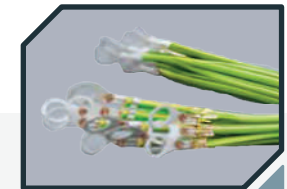
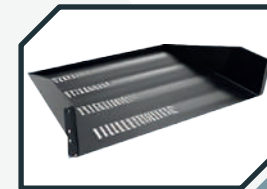
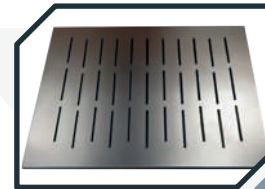
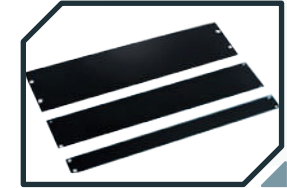

SOME OF CONSULTANTS AND MINISTRIES REFERANCE LIST



هيئة الزكاة والضريبة والجمارك
Zakat, Tax and Customs Authority



REFERENCE LIST

PROJECT	المشروع	PROJECT	المشروع	PROJECT	المشروع	PROJECT	المشروع
The red sea development company	تطوير البحر الأحمر	General Directorate of investigation	المديرية العامة للمباحث	STC WI FI 3G Offloading Project - KASC Jeddah	مدينة الملك عبدالله الرياضية	Schools Infrastructure Development - wave 2	شركة تطوير للمباني TBC
King Abdullah security project KAP1	مركز الملك عبدالله للمقرات الأمنية	The Saudi Central Bank (SAMA)	البنك المركزي السعودي	Ministry of Health - MOH West - MOH ESTERN	وزارة الصحة - المراكز الطبية	Rotana Hotel	فندق روتانا
King Abdullah security project KAP2	مركز الملك عبدالله للمقرات الأمنية	NEOM Hospital	مستشفى نيوم	DIGITAL TRUNKED RADIO SYSTEM WOA	الهيئة السعودية للكهرباء	Plazza in Hotel	فندق بلازا ان
King Abdullah security project KAP2-B	مركز الملك عبدالله للمقرات الأمنية	New Boulevards	البوليفرد - الهيئة العامة للترفيه	Qasem Hospital	مستشفى القصيم	Half Moon Beach Hotel	فندق هاف مون بيتش
King Abdullah security project KAP2-C	مركز الملك عبدالله للمقرات الأمنية	Winter Land	ونتر لاند - الهيئة العامة للترفيه	MOH - PHC	وزارة الصحة - الرعاية الصحية الأولى	Hyat Regency Hotel	فندق حياة ريجنسي
King Abdullah security project KAP4	مركز الملك عبدالله للمقرات الأمنية	City Walk Jeddah	سيني ووك جده - الهيئة العامة للترفيه	Qasem University Hospital	مستشفى جامعة القصيم	Hilton Garden in Hotel	هيلتون جاردن
Royal Commission for Riyadh City (RCRC)	الهيئة الملكية لمدينة الرياض	Nuclear and Radiological Regulatory	هيئة الوقاية النووية والإشعاعية	Riyadh Metro	مترو الرياض	Park Inn - Jeddah	فندق بارك ان - جده
Security Force Medical Center (SFMC)	المركز الطبي لقوات الأمن	ARAR AIRPORT	مطار عرعر	General Commission for Survey - Phase 3 & 2	الهيئة العامة للمساحة	Park Inn hotel - JRIYADH	فندق بارك ان - الرياض
200 BED HOSPITAL - TABUK	مستشفى ٢٠٠ سرير - تبوك	VSAT BACKUP HUB FOR SCECO	الهيئة السعودية للكهرباء	General Directorate for Health Affairs	المديرية العامة للشؤون الصحية	Narsis Buder Hotel	فندق ناريسيس بوديل
HAJ COMMAND AND HOLLY CAPITAL PROJECT	مشروع قيادة الحج	National Water Commission (NWC)	الهيئة الوطنية للمياه (NWC)	MOI CCTV Project	مشروع كاميرات المراقبة لوزارة الداخلية	Makan Hotel	فندق مكان
King Salman Hospital	مستشفى الملك سلمان	World Trade Center - WTC	مركز الملك عبدالله المالي	E - learning Project - Tatweer - School Project	مشروع التعليم الإلكتروني	MUNICIPALITY OF MEDINA	بلدية المدينة المنورة
Marriott Executive Apartment	فندق شقق الماريوت التنفيذية	ISLAMIC University	الجمعة الإسلامية	Royal Saudi Navy Force - RSNF	القوة البحرية الملكية السعودية	Tabuk Emirate	إمارة تبوك
South Boarder Guards Housing	إسكان الحدود الجنوبية	Samsung C&T	سامسونج - رايبغ	Saudi Electronic University	الجامعة السعودية الإلكترونية	MUNICIPALITY OF TAIF	بلدية الطائف
AL SALAM PALACE	قصر السلام	AL ULA University	جامعة العلا - جامعة طبية	Royal Saudi Air Force - RSAF	القوات الجوية الملكية السعودية	Eastern Province Emirate	إمارة المنطقة الشرقية
King Abdulla Finance District - KAFC	مركز الملك عبدالله المالي	Imam Moh'd University	جامعة الإمام محمد	Strategic Missile Force -SMF	قوة الصواريخ الاستراتيجية	Security Development and Planning Agency	وكالة التطوير والتخطيط الأمني
Jeddah Islamic Port	ميناء جدة الإسلامي	Prince Satam University	جامعة الأمير سطام	SAIC - RSAF PROJECT - USA	مشروع القوات الجوية الملكية - الولايات المتحدة الأمريكية	Royal Private Affairs	قصور ملكية
Ministry of Municipal and Rural Affairs	وزارة الشؤون البلدية والقروية	Al - Jouf University	جامعة الجوف	King Abdul Aziz Center National Dialogue	مركز الملك عبد العزيز للحوار الوطني	VSAT -COGS	في سات
Building of Secretary of the GCC	مبنى الأمين العام لمجلس التعاون	Hafar Al-Batin University	جامعة حفر الباطن	National Center for Technology Electrical Energy Systems	المركز الوطني لتكنولوجيا أنظمة الطاقة الكهربائية	Technical and Vocational Training Corporation	المؤسسة العامة للتدريب التقني والمهني
Radusson Blue Hotel	فندق راديسون بلو	Taima & Hakel University	جامعة تيماء وحقل	Qassim Emirates	إمارة القصيم	MIFON Project Phase 3	المرحلة 3 MIFON مشروع
National Water Commission (NWC)	الهيئة الوطنية للمياه (NWC)	Hakel University	جامعة حائل	SOIETZ Saudi Organization for Industry	الهيئة السعودية للمدن الصناعية	King Abdullah University Hospital	مستشفى جامعة الملك عبد الله بن عبد العزيز





شركة مصنع جاما للصناعات المعدنية
GAMMA FACTORY FOR METAL INDS.

WWW.GAMMA.COM.SA SALES@GAMMA.COM.SA
SAUDI ARABIA - KHARJ +966 50 524 9431
KHARJ INDUSTRIAL CITY - MODON

